

# Installation Manual

Navico Radar  
2kW and 4kW

English



# 1 Preface

## 1.1 FCC Statement

*Note:* This equipment has been tested and complies with the limits for a Class B digital device, pursuant to Part 15 of the FCC Rules. These limits are designed to provide reasonable protection against harmful interference in a normal installation. This equipment generates, uses and can radiate radio frequency energy and, if not installed and used in accordance with the instructions, may cause harmful interference to radio communications. However, there is no guarantee that interference will not occur in a particular installation.

If this equipment does cause harmful interference to radio or television reception, which can be determined by turning the equipment off and on, the user is encouraged to try to correct the interference by one or more of the following measures:

- Reorient or relocate the receiving antenna.
- Increase the separation between the equipment and receiver.
- Connect the equipment into an output on a circuit different from that to which the receiver is connected.
- Consult the dealer or an experienced technician for help.
- A shielded cable must be used when connecting a peripheral to the serial ports.

## 1.2 Industry Canada

Operation is subject to the following two conditions:

- (1) this device may not cause interference, and
- (2) this device must accept any interference, including interference that may cause undesired operation of the device.

Refer also to the system specifications section.

## 1.3 CE Compliance

Navico New Zealand, declares that this Radar Processor is in compliance with the essential requirements and other relevant provisions of Directive 1999/5/EC.

## **1.4 Disclaimer**

As Navico is continuously improving this product, we retain the right to make changes to the product at any time which may not be reflected in this version of the manual. Please contact your nearest distributor if you require any further assistance.

It is the owner's sole responsibility to install and use the instrument and transducers in a manner that will not cause accidents, personal injury or property damage. The user of this product is solely responsible for observing safe boating practices.

NAVICO HOLDING AS. AND ITS SUBSIDIARIES, BRANCHES AND AFFILIATES DISCLAIM ALL LIABILITY FOR ANY USE OF THIS PRODUCT IN A WAY THAT MAY CAUSE ACCIDENTS, DAMAGE OR THAT MAY VIOLATE THE LAW.

Governing Language: This statement, any instruction manuals, user guides and other information relating to the product (Documentation) may be translated to, or has been translated from, another language (Translation). In the event of any conflict between any Translation of the Documentation, the English language version of the Documentation will be the official version of the Documentation.

This manual represents the product as at the time of printing. Navico Holding AS. and its subsidiaries, branches and affiliates reserve the right to make changes to specifications without notice.

Copyright © 2008 Navico Holding AS.

## **1.5 Warranty**

The Navico warranty card is supplied as a separate document.

It is shipped with the product registration card.

In case of any queries, refer to [Navico.com](http://Navico.com).

## **1.6 Feedback from you**

Your feedback is important and helps Navico ensure that this manual is a valuable resource for all marine technicians. E-mail your comments or suggestions about this manual to the following address: [tech.writing@navico.com](mailto:tech.writing@navico.com)

# Contents

<b>1 Preface .....</b>	<b>1</b>
1.1 FCC Statement .....	1
1.2 Industry Canada .....	1
1.3 CE Compliance.....	1
1.4 Disclaimer .....	2
1.5 Warranty .....	2
1.6 Feedback from you.....	2
<b>2 Introduction to the Navico radar system .....</b>	<b>6</b>
2.1 Radar system overview .....	7
2.2 Warnings .....	7
<b>3 Install the radar.....</b>	<b>9</b>
3.1 Check the radar parts .....	10
3.2 Choose the scanner location .....	12
3.3 Power boat installations .....	13
3.4 Yacht installations .....	14
3.5 How to find the theoretical maximum detection range .....	14
3.6 How to find the optimum height for the scanner .....	15
3.7 How to reduce false echoes and shadow zones .....	16
3.8 Install the scanner unit .....	17
3.9 Install a scanner on a trestle.....	17
3.10 Install the radar processor .....	17
<b>4 Wiring the radar system .....</b>	<b>18</b>
4.1 Radar scanner 2 kW: Connect the optional interconnection cable (AA010088 / AA010089 to the scanner.....	18
4.2 Radar scanner 4 kW: Connect the optional interconnection cable (AA010090/AA010091) to the scanner.....	22
4.3 Radar processor: 2 kW and 4 kW connections.....	25
4.4 Radar processor 2 kW: Connect the interconnection cable to the radar processor .....	26
4.5 Radar processor 4 kW: Connect the interconnection cable to the radar processor .....	27
4.6 Connect the power cable .....	28
4.7 Connect the ground wire .....	29
4.8 Radar system checklist.....	29
<b>5 Connect Simrad GB40 or Northstar 8000i .....</b>	<b>30</b>
5.1 Parts needed to connect radar to a GB40 or 8000i system.....	30

5.2	Simrad GB40 using SimNet heading sensor .....	32
5.3	Northstar 8000i / Simrad GB40 using a NMEA 0183 heading sensor.....	33
5.4	Setup the radar with the GB40 or 8000i.....	35
<b>6</b>	<b>Connect Simrad NX40 / NX45, Northstar M84 / M121 .....</b>	<b>38</b>
6.1	Parts needed NX40/45 and M84/M121.....	38
6.2	Simrad NX40/45 Northstar M84/M121 radar connections .....	39
6.3	Set up the radar with the Simrad NX40/45 or Northstar M84/M121 .....	41
<b>7</b>	<b>Connect Northstar 6000i / 6100i .....</b>	<b>42</b>
7.1	Parts needed to connect to a Northstar 6000i / 6100i .....	42
7.2	Connect the radar processor to a 6000i or 6100i display .....	43
7.3	Connect the radar communications cable (NS003107) to the junction box .....	44
7.4	Configure the remote power control for a 6000i or 6100i (common power source) .....	46
7.5	Configure the remote power control for a 6000i or 6100i (different power sources).....	47
7.6	Set up the radar with the Northstar 6000i or 6100i .....	49
7.7	Turn the radar on and off .....	49
7.8	Configure the navigator communications .....	50
7.9	Adjust the appearance settings .....	50
7.10	Heading sensor requirements .....	51
7.11	Disable the heading sensor input .....	51
7.12	Calibrating the radar .....	51
7.13	Prepare for calibration .....	51
7.14	Tune the radar .....	52
7.15	Set the STC Curve .....	52
7.16	Set the trigger delay .....	52
7.17	Set the heading calibration (heading sensor installed).....	53
7.18	Set the heading calibration (heading sensor not installed) .....	54
7.19	Restore all the factory settings .....	54
7.20	Restore the factory appearance settings .....	54
7.21	Manual tuning procedure for the 6000i or 6100i system .....	55
<b>8</b>	<b>Connect to Lowrance Displays .....</b>	<b>56</b>
8.1	Parts needed to connect to Lowrance displays .....	56
8.2	Lowrance displays radar connection .....	58
8.3	Set up the radar with Lowrance displays.....	60
<b>9</b>	<b>Maintenance .....</b>	<b>66</b>
9.1	General maintenance .....	66
9.2	Scanner maintenance .....	66
9.3	Other maintenance items .....	66

<b>10 Troubleshoot the radar .....</b>	<b>67</b>
10.1 Technical support, service and repairs .....	67
10.2 Radar is not operating correctly .....	67
10.3 If the scanner fails to turn .....	67
10.4 How to reduce noise and interference .....	68
10.5 Make sure the power is present and correctly wired .....	68
<b>11 Drawings .....</b>	<b>69</b>
11.1 Radar scanner: 2 kW dimensions .....	69
11.2 Radar scanner 4 kW: Dimensions.....	70
11.3 Radar processor: Dimensions .....	71
<b>12 Specifications .....</b>	<b>72</b>
12.1 2 kW radar system specifications .....	72
12.2 4 kW Specifications.....	73
<b>13 Navico radar part numbers .....</b>	<b>75</b>

## 2 Introduction to the Navico radar system

This manual explains how to install the radar scanner and the Navico radar processor. It also explains how to connect the radar to the various brands of displays produced by Navico.

This manual should be used in conjunction with the installation manual provided with the display. It also explains how to set up the radar system after installation and gives you information on troubleshooting.

This manual is written for professional marine technicians, installation technicians, and service technicians. Dealers may also use information contained in this document.

PLEASE READ CAREFULLY BEFORE USE	
	WARNING indicates a potentially hazardous situation which, if not avoided, could result in death, serious injury or damage to property.

The Navico radar system platform is designed to work with many types and models of display head produced by Navico.

The radar systems consist of a scanner, radar processor and connection cables. Scanner models are available with power outputs of 2 kW, 4 kW, 6 kW, 10 kW and 25 kW to suit different customer requirements. Each scanner model has a corresponding radar processor module.



Note: 6 kW , 10 kW and 25 kW are covered in a separate manual

### Branding information

The Navico radar system is sold under different brands which share the same hardware. This manual is relevant to the following radar systems

	<b>SIMRAD</b>	<b>NORTHSTAR</b> ★	<b>LOWRANCE</b>
2 kW dome kit	DX42S-1	NS007001	LRA-1800
4 kW dome kit	DX64S-1	NS007002	LRA-2400
6 kW open array kit	TX06S-1	NS007003	N/A
10 kW open array kit	TX10S-1	NS007004	N/A
25 kW open array kit	TX25S-1	NS007005	NA

This manual describes how to interface to the following displays

Brand	Display heads that support the Navico radar system
	Simrad GB40 network system Simrad NX40/NX45
	Northstar 8000i network system Northstar 6000i and 6100i Northstar M84 Northstar M121



# LOWRANCE®

Globalmap Baja 540c, GlobalMap Baja 840c, Globalmap 5200c, Globalmap 5300c iGPS, GlobalMap 7200c, GlobalMap 7300c HD, GlobalMap 8200c, GlobalMap 8300c HD, GlobalMap 9300c HD, GlobalMap 9200c, LCX-38c HD, LCX-27c, LCX-37c, LCX-28c HD, LCX-112c, LCX-113c HD, LMS-520c, LMS-522c iGPS, LMS-522c iGPS Ice Machine, LMS-525c DF, LMS-527c DF iGPS, X510c, X515c DF

## 2.1 Radar system overview

The radar system is intended for use in a marine environment. It consists of a rotating scanner protected by a dome connected to a radar processor module by a prefabricated 15m (49ft) interconnection cable. A longer 20 m (65.5 ft) interconnection cable may be ordered separately. Scanner cables must be installed by a qualified radar technician.

A network or serial cable is to be used to connect the radar processor to a display head.

***An interconnection cable should only be installed by a qualified radar technician.***

The radar processor module connects to the various display heads using three different protocols. These are:

**Ethernet.** For more information on connecting via Ethernet (see "Connect Simrad GB40 or Northstar 8000i" page 30).

- **SIMRAD** GB40
- **NORTHSTAR** 8000i

### Serial Connectivity

**RS485** For more information how to connect to RS485 displays (see "Connect Simrad NX40 / NX45, Northstar M84 / M121" page 38).

- **SIMRAD** NX40 / NX45
- **NORTHSTAR** M Series

**RS422.** For more information how to connect to RS422 displays (see "Connect Northstar 6000i / 6100i" page 42).

- **NORTHSTAR** 6000i / 6100i
- **LOWRANCE** GlobalMap, LCX, LMS and X ranges of displays. See above list for specific models.

## 2.2 Warnings



***Use the radar at your own risk. Your radar was designed for use as a navigation aid. It should not be used for purposes that require precise measurements of direction, distance, topography or location. Always compare the navigation information received from your radar with data from other navigation aids and sources. When a conflict arises between the navigation data from your radar and data from other navigation aids, make sure you resolve the conflict before proceeding with navigation. A CAREFUL NAVIGATOR NEVER RELIES ON ONLY ONE METHOD TO OBTAIN NAVIGATION INFORMATION.***

**Caution: International Regulations for Preventing Collisions at Sea mandate indicate that when radar is on a vessel, the radar must be used at all times, regardless of weather conditions or visibility. Numerous court decisions have not only ruled the radar must be used, but that the radar operator must be knowledgeable in all operational aspects of radar performance; or otherwise face a greater risk of liability if an accident occurs.**



**WARNING: High Voltage Hazard**

**There is dangerously high voltage present within the radar scanner unit. Technicians must exercise extreme care when working inside the unit. ALWAYS remove power before removing the cover. Some capacitors may take several minutes to discharge, even after switching off the radar. Before touching the magnetron or any high voltage components, ground them with a clip lead.**



**WARNING: Microwave Radiation Hazard**

**The microwave energy radiated by a radar antenna is harmful to humans, especially to the eyes. NEVER look directly into an open waveguide or into the path of radiation from an enclosed antenna. Radar and other radio frequency radiation can upset cardiac pacemakers.**

**If someone with a cardiac pacemaker suspects abnormal operation, immediately turn off the radar equipment and move the person away from the antenna. Turn off the radar whenever it is necessary to work on the antenna unit or other equipment in the beam of the radar.**



*Note: Most countries accept that RF power density levels below 100 W/m<sup>2</sup> cause no significant RF hazard.*

Scanner Model	Vertical beam angle of scanner (degrees)	Minimum safe distance (100 Watts per m <sup>2</sup> average power density) Note 1	Minimum safe distance (10 Watts per m <sup>2</sup> average power density) Note 2
2 kW	30	1.6 ft (0.5 m)	4.6 ft (1.4 m)
4 kW	25	3 ft (0.9 m)	9.3 ft (2.8 m)

*Note: Limits apply to exposure within the vertical beam angle.*

*Note 1: Peak occupational exposure limit pursuant to IEC 60936 Clause 3.27 and IEC 62252 Clause 4.32*

*Note 2: General public exposure limit pursuant to IEC 60936 Clause 3.27 and IEC 62252 Clause 4.32*

## 3 Install the radar



***A radar unit should only be installed by a qualified marine technician, as potentially lethal high voltage is present along with heavy rotating parts.***

***There is a transmit interlock that prevents radar transmissions if the scanner is not rotating. However, a high voltage remains for a period of time after the system is turned off. If you are not familiar with this type of electronics, consult with a trained service or installation technician before attempting to service any part of the equipment.***

Installation includes:

- mechanical mounting
- electrical wiring
- configuring the display or network system to work with the radar
- adjusting the radar for proper performance

***Don't take any shortcuts, and follow these instructions carefully!***

This section explains how to:

- choose the correct location for the scanner
- install the scanner on a power boat or a yacht
- choose the correct location for the radar processor
- install the radar processor

***Read the important warning and safety information in the Preface before you install the radar.***

*Note: For best MARPA functionality, heading information received by the radar processor needs to be a minimum of 10 Hz, depending on the display head being used. See the section relating to the display head you are connecting to for more information.*

### 3.1 Check the radar parts

The Navico radar system consists of a scanner, a radar processor, and associated cables. some of which need to be ordered separately.

There are three main components of the radar system:



- The radar scanner
- The radar processor. The radar processor must match the power output of the scanner. For example, a 2 kW Scanner connects to a 2 kW processor box. Connection cables to attach to a display head are not shipped with this item and they must be ordered separately. The cables required will depend on the type of display head being used with the radar system. Later in this manual, you will find information about connecting particular display heads.
- Radar connection kit. This varies depending on display head that you are connecting to. Later in this manual, you will find information about connecting particular display heads.

Unpack the boxes carefully and check the contents against the packing lists. If anything is missing, contact your distributor.

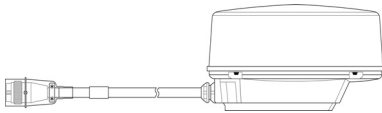
*Note: A parts list of what comes with scanner can be found inside the scanner packaging.*

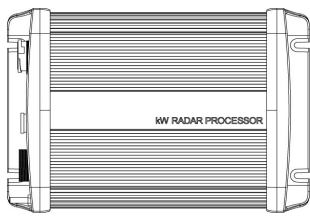
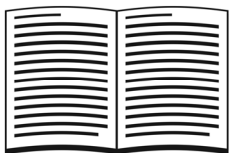
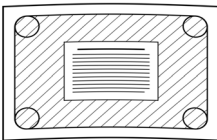
Qty.	Item	Description	Replacement Part No.
1			
	Simrad 2 kW scanner	TX06s Scanner w/cable	AA010024SIM
	Simrad 4 kW scanner	TX10s Scanner w/cable	AA010025SIM
	Northstar 2 kW scanner	NS007001 Scanner w/cable	AA010024NOR
	Northstar 4 kW scanner	NS007002 Scanner w/cable	AA010025NOR
	Lowrance 2 kW scanner	LRA-1800 Scanner w/cable	AA010024LOW
	Lowrance 4 kW scanner	LRA-2400 Scanner w/cable	AA010025LOW

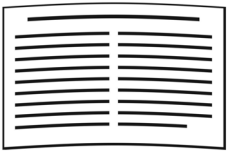
AA010012 2 kW Radar processor standard components			
Qty.	Item	Description	Part No.
1		2 kW Radar processor 4 kW Radar processor	AA010012 AA010013
1		This manual	MN000783
1		Installation template	LA000276B-G

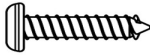
1		Product registration card	CD000085
1		Warranty card	CD000260
4		Mounting screws	HR000061

### 3.2 Choose the scanner location

The radar's ability to detect targets depends greatly on the position of its scanner. The ideal location for the scanner is high above the vessel's keel line where there are no obstacles.

A higher installation position increases the radar ranging distance, but it also increases the minimum range around the vessel where targets cannot be detected.

*Also see the sections on installing the scanner on a power boat or yacht.*

When you're deciding on the location, consider the following:

- the length of the interconnection cable supplied with your radar is usually sufficient. If you think you'll need a longer cable, consult your dealer before installation, because a longer cable may reduce the performance of the radar.
- if the roof of the wheelhouse is the highest existing location, consider installing a radar mast or a pedestal on which you can mount the scanner. You may also need to construct a working platform for your own safety during installation and servicing work.
- if you mount the scanner on a pedestal or base, ensure that rain and sea spray can drain away from it rapidly.
- if you locate the scanner on the mast, position it on the forward side so that there is a clear view to the front of the vessel.
- the scanner is usually installed parallel to the line of the keel.
- ensure that the location site provides the scanner with a clear view of the front of the vessel.

#### DON'T DO THIS!

- DON'T install the scanner too high up, where its weight will alter the stability of the vessel and cause degradation of the radar picture over short ranges (see "How to find the optimum height for the scanner" page 15).
- DON'T install the scanner close to lamps or exhaust outlets. The heat emissions may cause the equipment to break down. Soot and smoke will degrade the performance of the radar.
- DON'T install the scanner close to the antennas of other equipment such as direction finders, VHF antennas, GPS equipment and so on, because it may cause interference.
- DON'T install the scanner where a large obstruction (such as an exhaust stack) is at the same level as the beam, because the obstruction is likely to generate false echoes and/or shadow zones.
- DON'T install the scanner where it will be subjected to strong vibrations (such as a derrick post) because these vibrations will degrade the performance of the radar.
- DON'T install an open array close to halyards or flags because the wind could wrap these around the scanner and jam it.



***DON'T install the scanner inside of the recommended compass safe distances of any navigation instruments such as the magnetic compass and the chronometer. The compass safe distances are as follows:***

2 kW radar	STD 0.7m (2.3 ft) / STEER 0.5 m (1.6 ft)
4 kW radar	STD 2.0 m (6.5 ft) / STEER 1.5 m (5 ft)

### 3.3 Power boat installations

Normally, you should install the scanner horizontally, to produce an equal sweep around the boat:

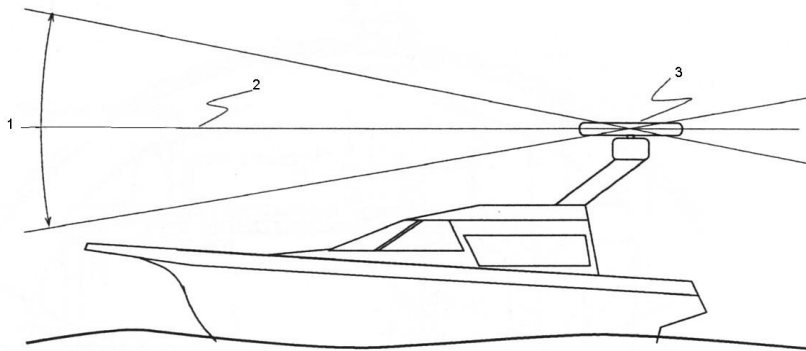

However, when a power boat is traveling at high speed, the bow rises up out of the water and if the elevation angle (trim) of the bow is raised up so that it equals, or exceeds, 50% of the vertical beam width of the radar, this can cause two problems:

- Ahead of the power boat, the beam is projected too high to sweep the water surface effectively. Targets can be missed completely or appear at a very poor resolution on the display screen.
- Astern of the power boat, the beam is projected too low and is concentrated over a small area of water so that sea clutter becomes a problem on the display screen.

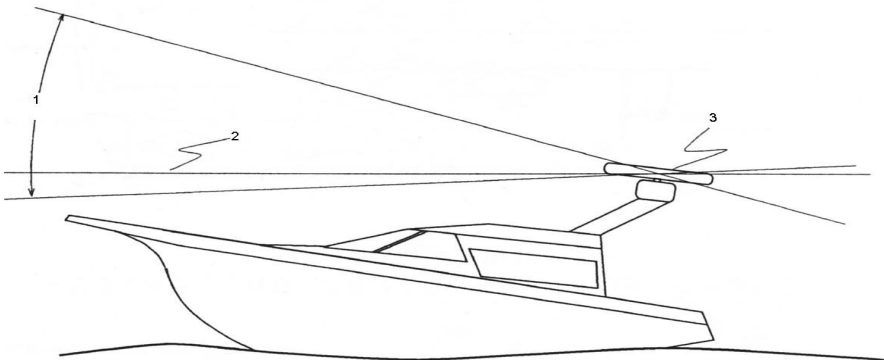

In this case, you're recommended to install the scanner so that it is tilted down at the front, at an angle that will produce an almost horizontal sweep when the power boat is running at speed.

### 3.4 Yacht installations

Normally you should install the scanner horizontally, to produce an equal sweep around the yacht. However, a yacht heels over to the lee side, and when the heel angle exceeds 50% of the vertical beam width of the radar, this can cause two problems:

- On the windward side of the yacht, the beam is projected too high to sweep the water surface effectively. Targets can be missed completely or appear at very poor resolution on the display unit.
- On the lee side of the yacht, the beam is projected too low and is concentrated over a small area of water so that sea clutter becomes a problem on the display unit.

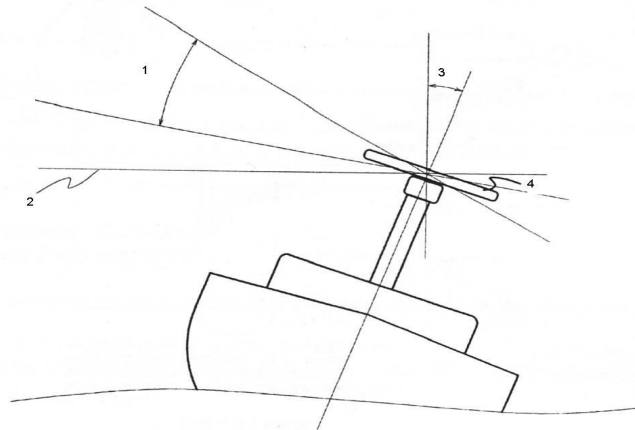

In this case, you're recommended to install the scanner on a gimbal mounting so that it can operate effectively in a heavy swell or when the yacht is heeled over.

### 3.5 How to find the theoretical maximum detection range

Propagation of the radar beam can vary, depending on the properties of the air through which it is traveling. Under normal conditions, the distance that the radar beam travels is approximately 10% further than the distance to the optical horizon.

You can calculate the theoretical distance traveled by the radar beam using the following formula:

$$D = 2.23 (\sqrt{h_1} + \sqrt{h_2})$$

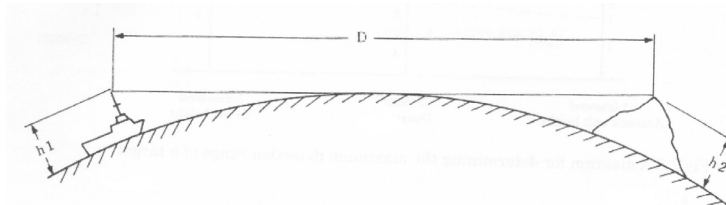

where:

- D is distance traveled by the radar beam
- h1 is the height above sea level of the scanner
- h2 is the height above sea level of a target

An example is shown below:

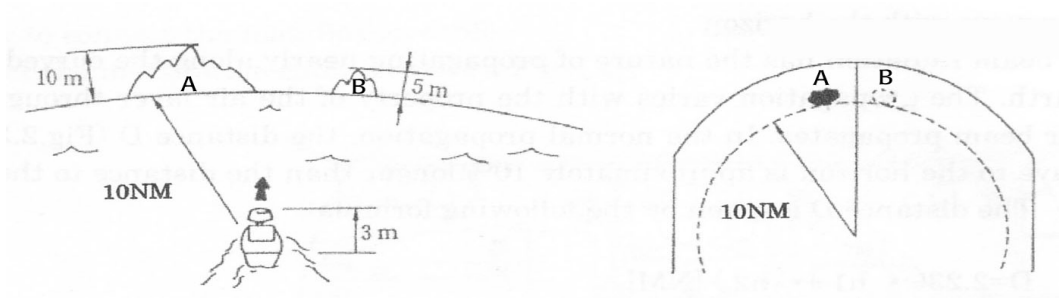



In this example, the scanner is installed on the vessel at a height of 3 m (10 ft) above sea level (h1). Island A is 10 m (33 ft) high (h2) and for comparison, island B is 5 m (16.4 ft) high (h2). Both islands are at a distance (D) of 10 nautical miles from the vessel.

Calculations using the formula show that, at this distance, the radar can only detect objects that are more than 7.6 m (25 ft) high, which means that island A is shown on the radar but island B is not shown.

Remember that:

- The maximum detection range of the radar is limited by the curvature of the earth's surface under normal conditions of wave propagation.
- Bad weather conditions can reduce the maximum detection range.

### 3.6 How to find the optimum height for the scanner

The optimum height for the scanner is as close as possible to the A-B line for best performance.

How to find the A-B Line:

The vertical extent of the radar beam is  $2\theta^\circ$ , so most of the radar beam is concentrated within this angle, meaning that outside of this angle, the radar beam will be very weak.

Scanner model	$\theta^\circ$ value (half the -3 dB beam width)
2 kW	15
4 kW	12.5

An example of an A-B Line is shown in the picture. If you install the scanner below the A-B line, the scanner will be too low. It will be difficult to acquire distant targets and the superstructure will be more likely to impede the passage of the beam and generate false echoes. If the scanner is installed too high above the A-B line, the beam will miss close targets and increase sea clutter return.

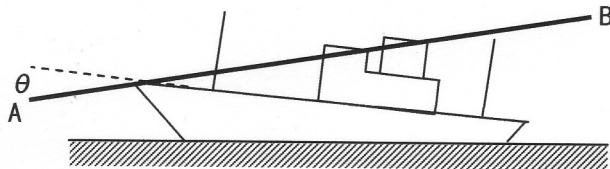

You can find the A-B line for any vessel as follows:

- Using a scaled drawing of the vessel, lay a rule along the line of the main deck and continue this forwards as a dashed line extending beyond the bow.
- Using a protractor, measure the  $\theta^\circ$  value (for your scanner model) below the dashed line at the bow and draw in a new line along this angle.
- Extend the new line back beyond the bow of the vessel. This is the A-B line.

### 3.7 How to reduce false echoes and shadow zones

False echoes can be produced on the radar display if the scanner is installed too close to an object on the vessel's superstructure. This object can block the radar beam and reflect it back, generating false echoes and shadow zones.

If you are having problems with false echoes and/or shadow zones, re-install the scanner at a higher location where the radar beam will be clear of any obstructions.

If this is not possible, try relocating the scanner away from the central keel line of the vessel to the starboard side. This will move any shadows to the port side, maximize the radar view of your give way sector, and ensure a clear view of the area around the vessel at the bow.

Use the following formula to calculate the distance that you'll need to move the scanner:

$$L_s = 0.4R + D/2 \quad (\text{when } R \text{ is less than } 49 \text{ ft [15 m]})$$

$$L_s = 0.025R + D/2 \quad (\text{When } R \text{ is greater than or equal to } 49 \text{ ft [15 m]})$$

where:

$L_s$  = distance to be moved from the keel line

$D$  = diameter of the obstacle

$R$  = distance between the antenna and the obstacle

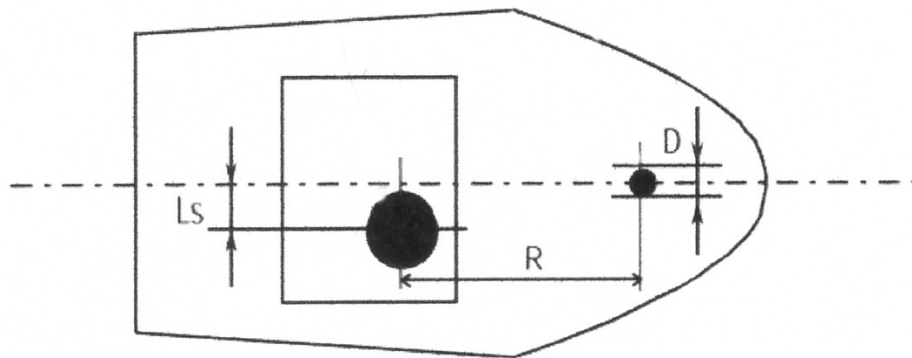

### 3.8 Install the scanner unit

*Important: Remember that you must screw the bolts into place from the under side of the location site, because the shape of the dome prevents you from installing the bolts from the top side. Ensure that you can access the under side of the location site before drilling.*

Find the paper mounting template and tape it securely to the chosen location site. Before drilling, check that:

- the location site is not more than 0.6" (15 mm) thick.
- You have oriented the mounting template correctly so that the front of the scanner unit will face the front of the vessel; and
- the location site allows the drain hole to empty.

Drill the four holes plus the drain hole where shown. Remove the mounting template, then position a rubber washer over each hole on the scanner. Ensure that the slot in the rubber washer is aligned with the rib on the scanner.

Position the scanner carefully over the bolt holes so that they are aligned with the holes of the rubber washers and the drill holes.

Place a spring washer then a plain washer onto each bolt, as shown. Screw each bolt into each drill hole from the under side of the location site, and tighten securely

*Note: Use the bolts supplied as these are hardened stainless steel and the correct length.*

### 3.9 Install a scanner on a trestle

Depending on your chosen location for the scanner, it may be easier to install the scanner if you fabricate a trestle (or radar mast) on which you can mount the scanner.

The trestle must be sturdy and secure, and capable of supporting the scanner in all weather conditions.

You are recommended to install the base of the trestle parallel to the water surface.

Orient the trestle so that the cable inlet on the scanner will face the stern, and so that the scanner can be mounted at the correct angle (as discussed in the "Power boat installation" section).

Make sure that the edges of the trestle won't trap water.

### 3.10 Install the radar processor

Install the radar processor in a dry location away from spray, rain, drips and condensation.

The radar processor must be located where it can be easily connected to the ship's ground, the interconnection cable, the power cable and the radar communications cable or the network cable. Check that these cables and the ship's ground can easily reach the radar processor BEFORE you drill.

The radar processor dimensions are shown on the installation template. Follow the instructions on the installation template to install the radar processor.

## 4 Wiring the radar system

### 4.1 Radar scanner 2 kW: Connect the optional interconnection cable (AA010088 / AA010089 to the scanner

If you have the standard 2 kW radar system, the scanner is supplied with the 15 m (49 ft) interconnection cable already connected and you can ignore this section.

If you have ordered the longer 20 m (65.5 ft) interconnection cable, follow the guidelines in this section.

**Note: An interconnection cable should only be installed by a qualified radar technician.**

- Unscrew and remove the cover of the scanner, lifting it vertically to avoid bumping it against the antenna.

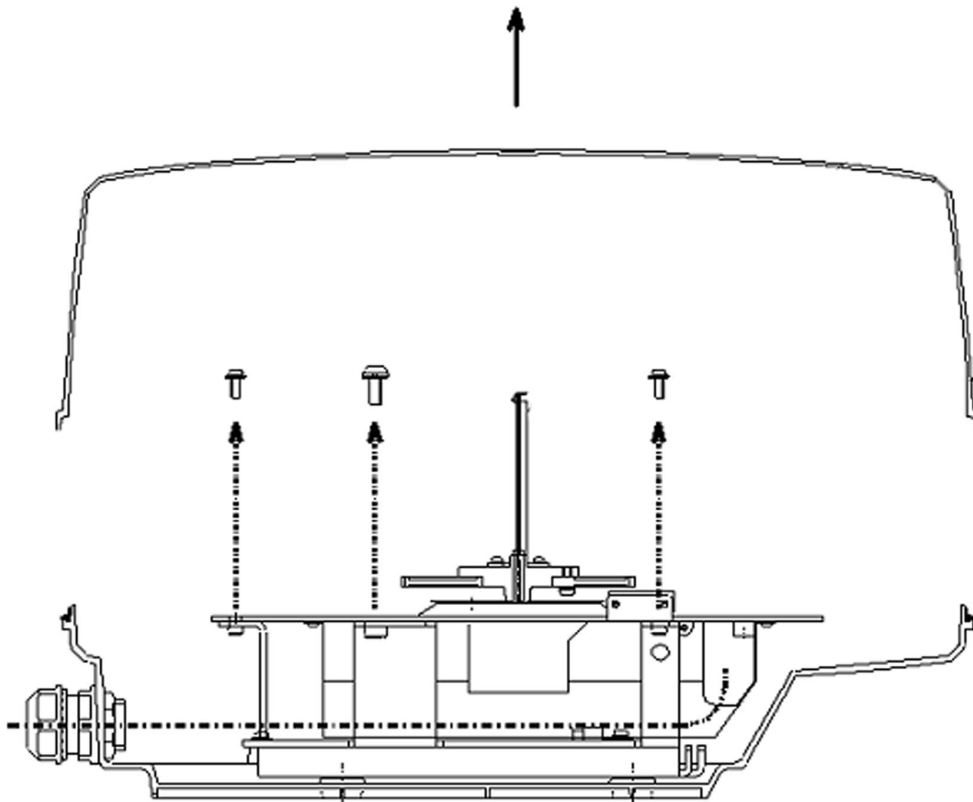

- Carefully lift the main unit and stand it upright in the slot on the scanner casing:

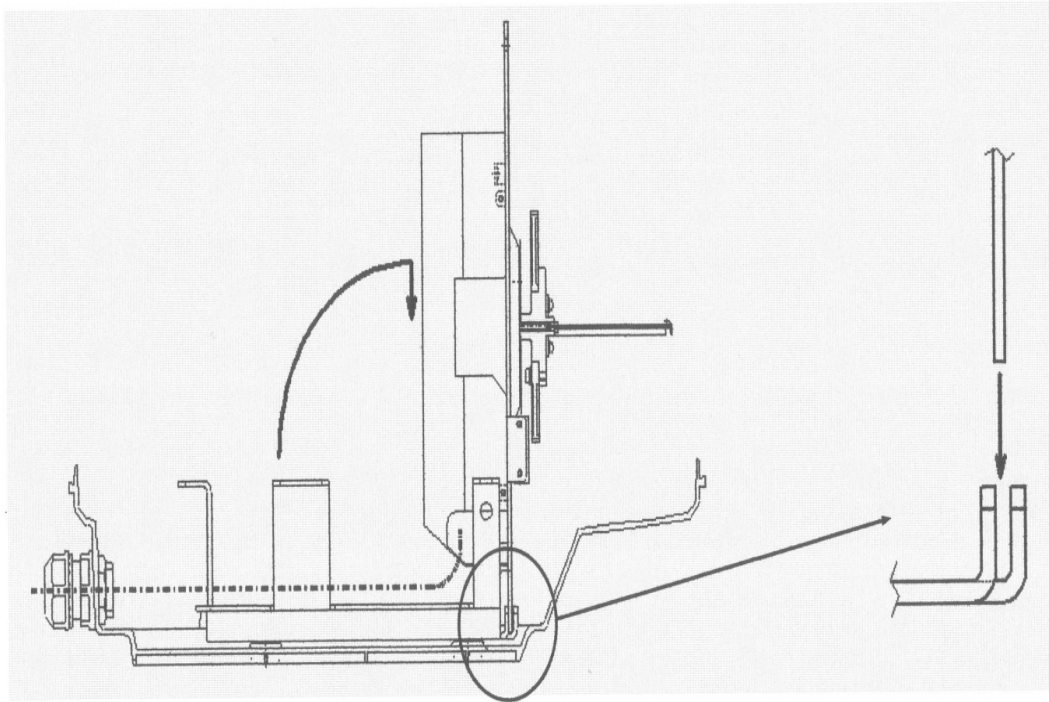

- Remove the shield cover from the underside of the main unit to expose the connector locations and ground terminal location.
- The broken line shows the route for the interconnection cable.
- Identify the connector ends B, C, and D on the 2 kW interconnection cable. Connector D is a grounding strap.

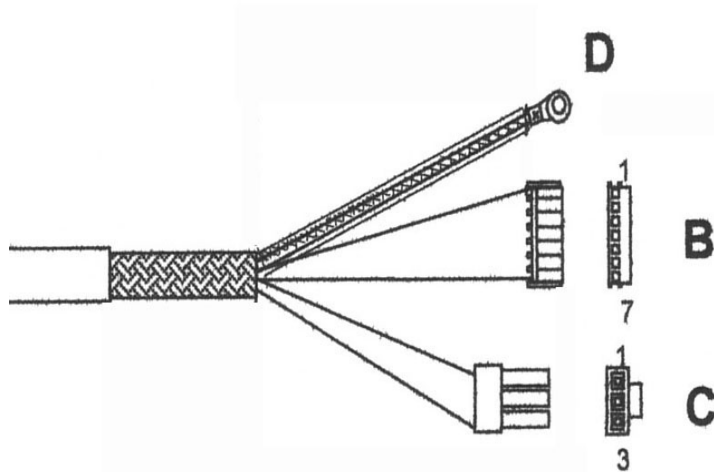

- Place the locking nut, gasket A and gasket B over the end of the interconnection cable in the order shown, then push the interconnection cable through the cable entry point into the radome. (Ensure that you push through sufficient cable to easily join the connectors.)
- At the cable entry point, take care that the grooves in gaskets A and B are opposite each other (see the figure). Tighten the locking nuts to hold the interconnection cable firmly in place and to provide a waterproof seal.

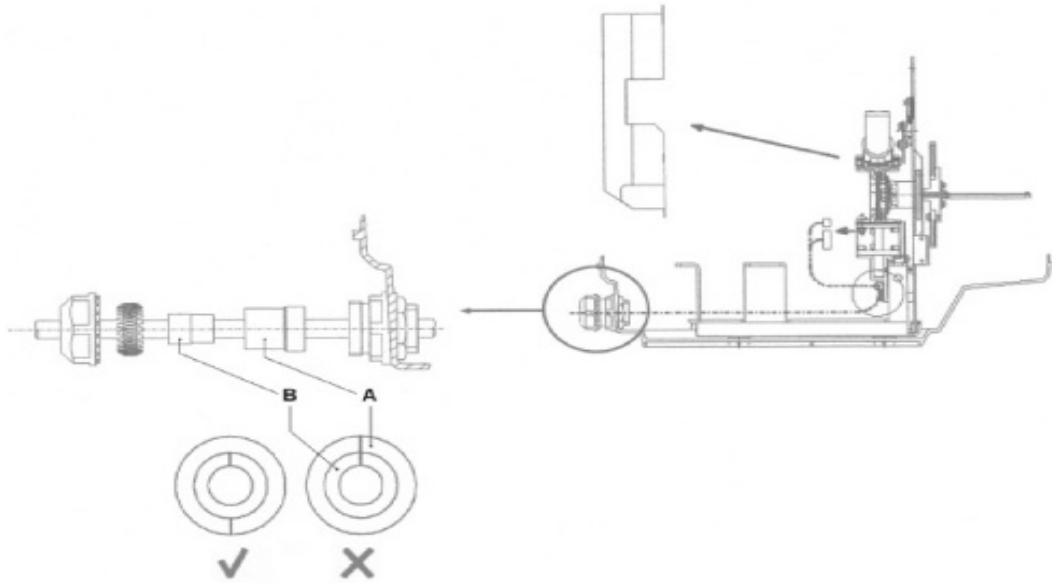

- Place the internal locking nut over the end of the interconnection cable, then attach connectors B and C to the connectors (as shown in the figure).

The broken line shows the route for the interconnection cable.

- Attach connector D to one of the screws close by to provide grounding (as shown in the figure).

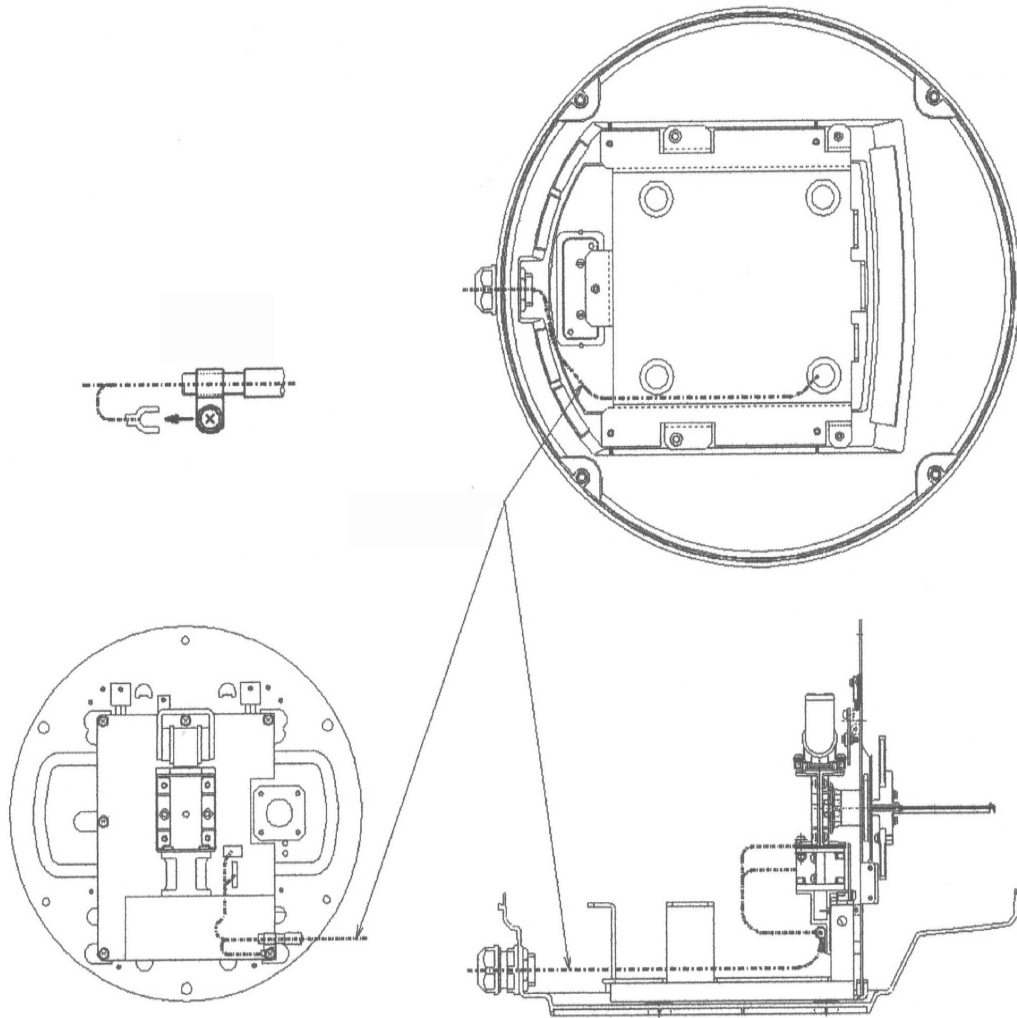

The wiring details for the connector ends (B, C, and D) are as follows:

2 kW interconnection cable (AA010088 / AA010089) connector ends					
Pin	Color/Name	AWG size	B	C	D
1	Green (thick)	#12		1	
2	Yellow (thick)	#12		2	
3	Green (thin)	#24	7		
4	Clear coax signal	#24	4		
5	Drain wire for 4	#24	5		
6	Drain wire for 7	#24	3		
7	Black coax signal	#24	2		
8	White	#24	6		
9	Yellow	#24	1		
10	White (thick)	#12		3	
Shell	Braid shield				X

## 4.2 Radar scanner 4 kW: Connect the optional interconnection cable (AA010090/AA010091) to the scanner

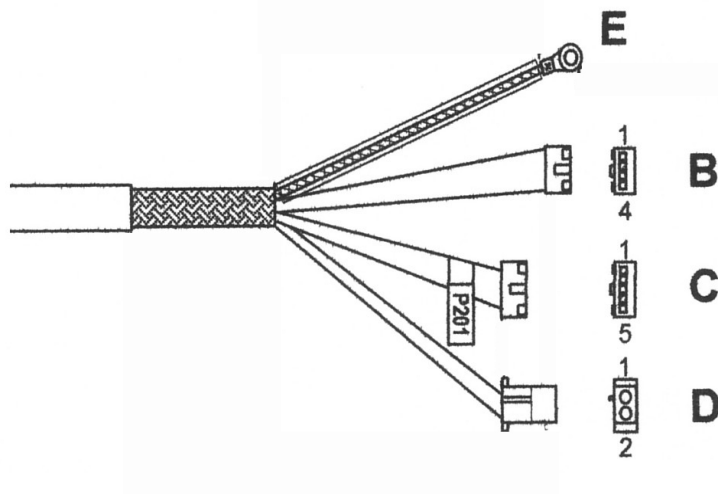

- Unscrew and then remove the cover of the scanner, lifting it vertically to avoid bumping it against the antenna.
- Identify the connector ends B, C, D and E on the 4 kW interconnection cable (AA010090 or AA010091). Connector end E is an Earthing strap.
- Slacken or remove the strain relief clamp just inside the radome close to the cable entry point.
- Place the locking nut, gasket A and gasket B over the connector end of the interconnection cable in the order shown, then push the interconnection cable through the cable entry point into the radome. (Ensure that you push through sufficient cable to easily connect to the J connectors as described in the following step.
- At the cable entry point, take care that the grooves in gaskets A and B are opposite each other (see the figure). Tighten the locking nuts to hold the scanner cable firmly in place and to provide a waterproof seal.



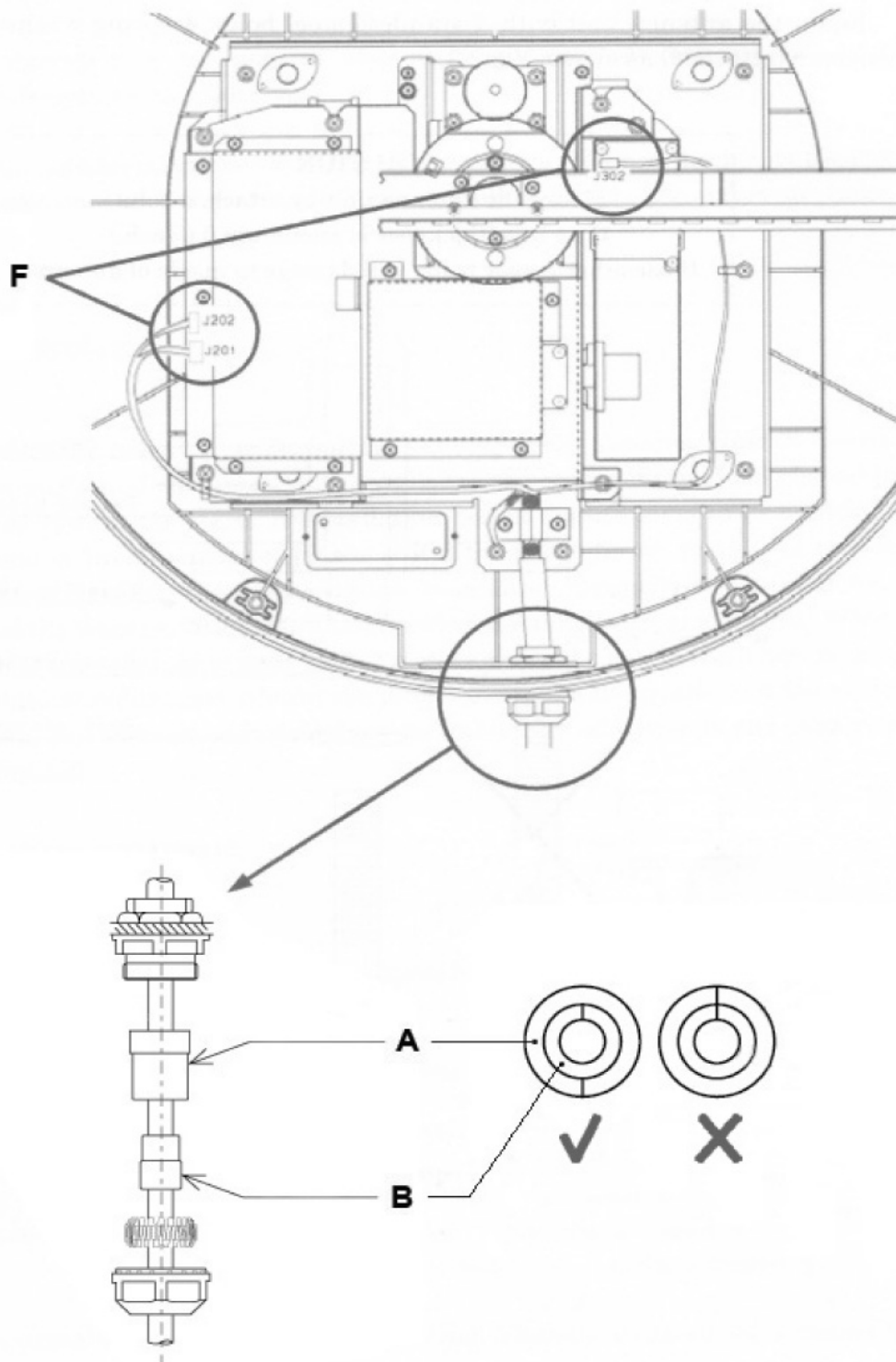

- Place the internal locking nut over the end of the scanner cable in the order shown, then attach the three connectors on the interconnection cable to the three connectors (as shown at F in the figure):
  - Connector end B to J302
  - Connector end C to J202
  - Connector end D to J201
- Tighten the strain relief clamp then connect Connector end E to one of the screws close by to provide an Earth.

The wiring details for the connector ends (B, C, D, and E) are as follows:

<b>4 kW interconnection cable (NS00310X) connector ends</b>						
<b>Pin</b>	<b>Color/Name</b>	<b>AWG size</b>	<b>B</b>	<b>C</b>	<b>D</b>	<b>E</b>
1	Blue (thick)	#16			1	
2	Purple (thick)	#16			1	
3	Red (thick)	#16			2	
4	Yellow (thick)	#16			2	
5	Drain wire (Coax line)	#24	2			
6	No connection					
7	No connection					
8	No connection					
9	Yellow (thin)	#24 twist pair	3			
10	Clear Coax line	#24	1			
11	No connection					
12	Green (thin)	#24		5		
13	White (thin)	#24 twist pair	4			
14	Drain wire	#24		2		
15	Shield line	#24		1		
16	Orange (medium)	#18		3		
Shell	Braid shield					X

### 4.3 Radar processor: 2 kW and 4 kW connections

There are four interface connectors on the front of the radar processor, two L.E.D plus a chassis ground.

The Navico radar processor can be connected to any of the following display heads (please refer to the chapter relevant to you display head)

- Simrad NX40 NX45, GB40
- Northstar 8000i, 6100, 6000i, M84, M121
- Lowrance GlobalMap 9300c HD, 9200c, 8300c, 8200c, Baja 440c, 7300c, 7200c, 5200c, 5300c, Baja 540c, LCX-113c HD, LCX-112c, LCX-38c HD, LCX-37c, LCX-28c HD, LCX-27c, LMS-520c, LMS-522c iGPS, LMS-525c DF, LMS-527c DF iGPS, X510c, X515c DF

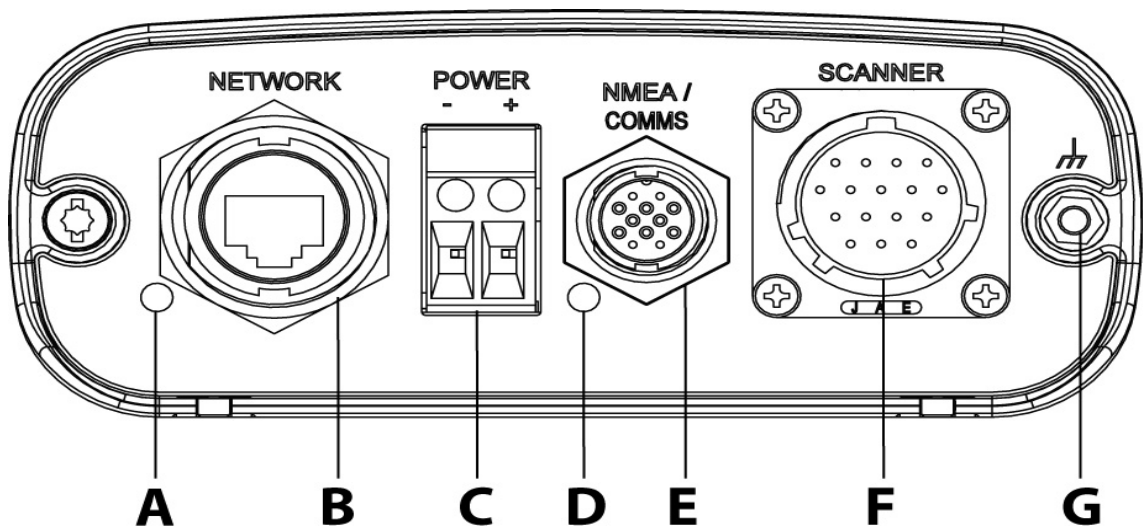

Radar processor interface connectors		
Key	Connector function	Connects to...
A	LED (Ethernet)	Displays status of the Ethernet network connection
B	Network: Ethernet communications for Simrad GB40 and Northstar 8000i	GB40 / 8000i network, using Navico ethernet network cables, available in 0.5 m, 2 m, 5 m and 10 m lengths. (order cable separately)
C	Power (+ve and -ve)	2kW system: 12 V DC ONLY 4kW system: 12-24 V DC
D	LED Power	Displays power status
E	NMEA / Coms: Data communications for: Simrad NX40/45 Lowrance displays: for a full list of compatible displays (see "Introduction to the Navico radar system" page 6) Northstar 6000i, 6100i, Northstar M84 and M121 systems (6kW only) NMEA communications for compass input NB! order cable separately.	Simrad NX40/45, Northstar 84/121 use the communication cable AA010114 (also included the radar connection kit AA010112) Lowrance displays use the RIM300 cable 6000i or 6100i display unit, using radar communications cable (NS003107) 6000i, 6100i, M84, M121 or 8000i remote power signals, relay or ignition; cable not supplied SimNet heading via AT10HD (24006694) for GB40 Systems NMEA0183 compliant compass
F	Scanner communications	Scanner, using the interconnection cable
G	Grounding point	Vessel's ground using ground wire

## 4.4 Radar processor 2 kW: Connect the interconnection cable to the radar processor

If the Interconnection cable is not attached or needs to be changed use the following steps

Run the 2 kW interconnection cable (either the standard 15 m [49 ft] or the optional 20 m [65.5 ft] cable) from the scanner to the radar processor.

Push the round connector (A) of the 2 kW interconnection cable into the scanner connection on the radar processor and tighten the locking nut.

The interconnection cable pin details are provided here for information, in case the connector needs to be removed to feed the cable.

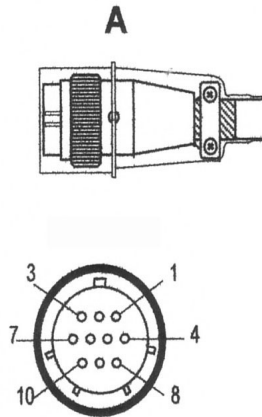

The front view of the 2 kW interconnection cable is shown above.

2 kW interconnection cable pin details			
Pin	Color/Name	Signal name	AWG size
1	Green (thick)	Power	#12
2	Yellow (thick)	Power GND	#12
3	Green (thin)	Pulse width	#24
4	Clear coax signal	Video	#24
5	Drain wire for 4	Video GND	#24
6	Drain wire for 7	Trig GND	#24
7	Black coax signal	Trig/STC	#24
8	White	BZ Tune to scanner	#24
9	Yellow	Tune from scanner	#24
10	White (thick)	No connection	#12
Shell	Braid shield		

## 4.5 Radar processor 4 kW: Connect the interconnection cable to the radar processor

- Run the 4 kW interconnection cable from the scanner to the radar processor.
- Push the round connector (A) of the 4 kW interconnection cable into the scanner connection on the radar processor and tighten the locking nut.
- The interconnection cable pin details are provided here for information, in case the connector needs to be removed to feed the cable.

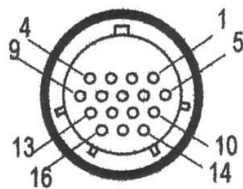
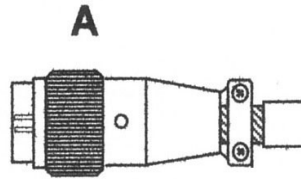

The front view of the 4 kW interconnection cable is shown above.

4 kW interconnection cable pin details				
Pin	Signal Name	Description/Remarks	Color/Name	AWG size
1	2 A Input DC power	Isolated Ground	Blue (thick)	#16
2	2 A Input DC power	Isolated Ground	Purple (thick)	#16
3	1 A Input DC power	Isolated DC 10.8 V to 42 V	Red (thick)	#16
4	1 A Input DC power	Isolated DC 10.8 V to 42 V	Yellow (thick)	#16
5	VDE	Video Return Coax return	Drain wire (Coax line)	#24
6	No connection	Not used	No connection	
7	No connection	Not used	No connection	
8	No connection	Not used	No connection	
9	COM(+)	COM PORT RS485	Yellow (thin)	#24 twist pair
10	VD	Video Output Coax cable @-2 V=100 dB	Clear Coax line	#24
11	No connection	Not used	No connection	
12	BZ	Bearing Zero BZ - HDG Flash - open collector	Green (thin)	#24
13	COM(-)	COM PORT RS485	White (thin)	#24 twist pair
14	TIE	Trigger Return Shield return	Drain wire	#24
15	TI	Trigger Shield cable @ 1/PRF	Shield line	#24
16	BP	Bearing Pulse 2048 pulses/rotation	Orange (medium)	#18
Shell			Braid shield	

## 4.6 Connect the power cable

A power cable is NOT supplied with the radar processor. A fuse / circuit breaker must be used on the power cable supplying the radar processor.

**Check the system specifications section for the recommended DC input voltage.**

The power cable and fuse/circuit breaker requirements are shown in the table.

Scanner	Fuse/Circuit breaker rating	Maximum length of power cable	Power cable size
2 kW 12 V DC ONLY	5 A	10 m (33 ft)	14 AWG
4 kW 12-24 V DC	10 A	8 m (26 ft)	14 AWG

Typically the fuse/circuit breaker would be located in a fuse/circuit breaker box with the fuses/circuit breakers for other devices.

The radar processor must have its own exclusive fuse/circuit breaker. The fuse/circuit breaker should be labeled appropriately.

To connect the power cable to the radar processor, you must:

- Strip away approximately 0.4" (10 mm) of the shielding at the end of the power cable, and then identify the positive wire and the negative wire
- Unscrew the small holding screw from the positive power cable input connector (identified by the + sign) on the radar processor
- Insert the bare end of the positive wire into the positive power cable input connector to make a connection
- Tighten the small holding screw to hold the positive wire in place. Gently pull on the positive wire to ensure that it is secured
- Repeat this process to connect the negative wire to the negative power cable input connector (identified by the – sign)



*Note 2 kW system is for 12 V DC only.*

## 4.7 Connect the ground wire

The radar processor has a chassis ground connection stud located on the far right hand side of the unit. The chassis ground is DC isolated from power (-ve) to eliminate the risk of galvanic corrosion.

If you are installing the radar processor on a vessel with a metal hull, connect the radar processor chassis ground to the hull at the closest possible location, using 12 AWG wire (or thicker):

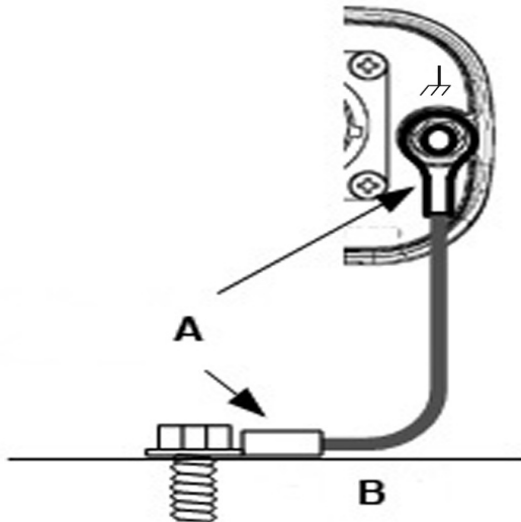

The eyelets must be crimped or soldered at both locations (A) and the method of connection to the vessel's hull is shown at (B).

If you are installing the radar processor on a vessel with a non-metallic hull, connect the radar processor chassis ground to the vessel's ground network. If a vessel's ground network is not available, leave the radar processor chassis ground unconnected.

## 4.8 Radar system checklist

When you've finished the wiring, visually check that:

- Each component is securely mounted and able to withstand rough sea conditions.
- All the cables are correctly installed; and
- any cable shield mesh is correctly configured,
- all cable entry points are watertight, and
- water can't leak into the scanner.

Now you are ready to interface to your choice of display head.

## 5 Connect Simrad GB40 or Northstar 8000i

Both the Simrad GB40 and the Northstar 8000i systems interface to the Navico radar via an ethernet network. Although the two types of display system have the same type of ethernet network connectivity, they differ in the way they accept heading information for MARPA and accurate chart overlay.

The Northstar 8000i requires NMEA 0183 heading information to be sent to both the Master NavComputer and the radar processor module. The Simrad GB40 NavComputer gets heading information over SimNet. The radar processor module requires the use of an AT10HD SimNet to NMEA 0183 converter to feed SimNet heading information at 10 Hz for optimum MARPA function.



*Note. Do not use a standard AT10 converter, as this only passes heading information at 4 Hz.*

### 5.1 Parts needed to connect radar to a GB40 or 8000i system

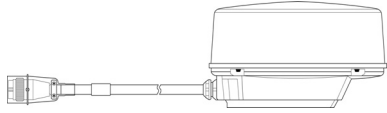
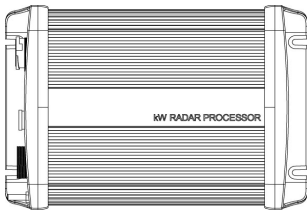
Qty.	Item	Description	Part No.
1		Scanner unit with interconnection cable 2 kW or 4 kW	For scanner part numbers (see "Navico radar part numbers" page 75)
<b>Radar Processor</b>			
Qty.	Item	Description	Part No.
1		2 kW Radar Processor 4 kW Radar Processor	AA010012 AA010013

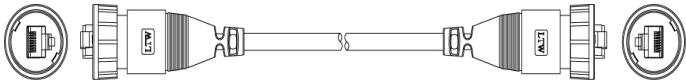
<b>Ethernet cables: (Simrad GB40 and Northstar 8000i)</b>	
The connection between the radar processor and the GB40/8000i system is via an ethernet network. One ethernet cable is used to connect the radar to a Navico 8 port network linke. Select the desired length. If there is only one NavComputer with radar, a crossover cable can be used.	
	
Part No.	Description
AA010079	Ethernet cable 0.5 m (1.6 ft) male / male connectors
AA010080	Ethernet cable 2 m (6.5 ft) male / male connectors
AA010081	Ethernet cable 5 m (16.5 ft) male / male connectors
AA010082	Ethernet cable 10 m (30 ft) male / male connectors
AA010083	Ethernet cable joiner 0.5 m (1.6 ft) female / female
AA010086	Ethernet cable bulk roll 100 m (328 ft) un-terminated
AA010087	Ethernet cable bulk roll 300 m (985 ft) un-terminated
AA010085	Ethernet connector. Field terminating ethernet connector for bull ethernet cable

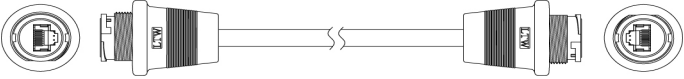

<b>Ethernet crossover cable</b>	
Used to connect the radar processor directly to a NavComputer. Cable has female connectors on both ends and joins two of the above standard ethernet cables together (see "Simrad GB40 using SimNet heading sensor" page 32)	
AA010084	

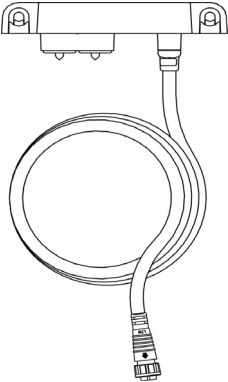
<b>Optional parts to connect (GB40 only)</b>	
24006694	
	<p><b>AT10-HD</b></p> <p>This is used to supply the radar processor with heading information at 10 Hz from a SimNet heading source. This is needed for MARPA and accurate chart overlay. This connects to the 12 pin NMEA / COMMS connector on the radar processor.</p>

<b>Optional parts to connect (GB40 and 8000i) utility cable</b>	
AA010070	
	<p>This is used to supply the radar processor with NMEA 0183 heading information at 10 Hz from an NMEA 0183 heading source. This connects to the 12 pin NMEA / COMMS connector on the radar processor.</p>

## 5.2 Simrad GB40 using SimNet heading sensor

The diagram below details how to connect the Navico radar to a GB40 system using an Ethernet crossover cable (F), or using the 8 port ethernet linker (G). High speed heading is via SimNet (D).

For key information

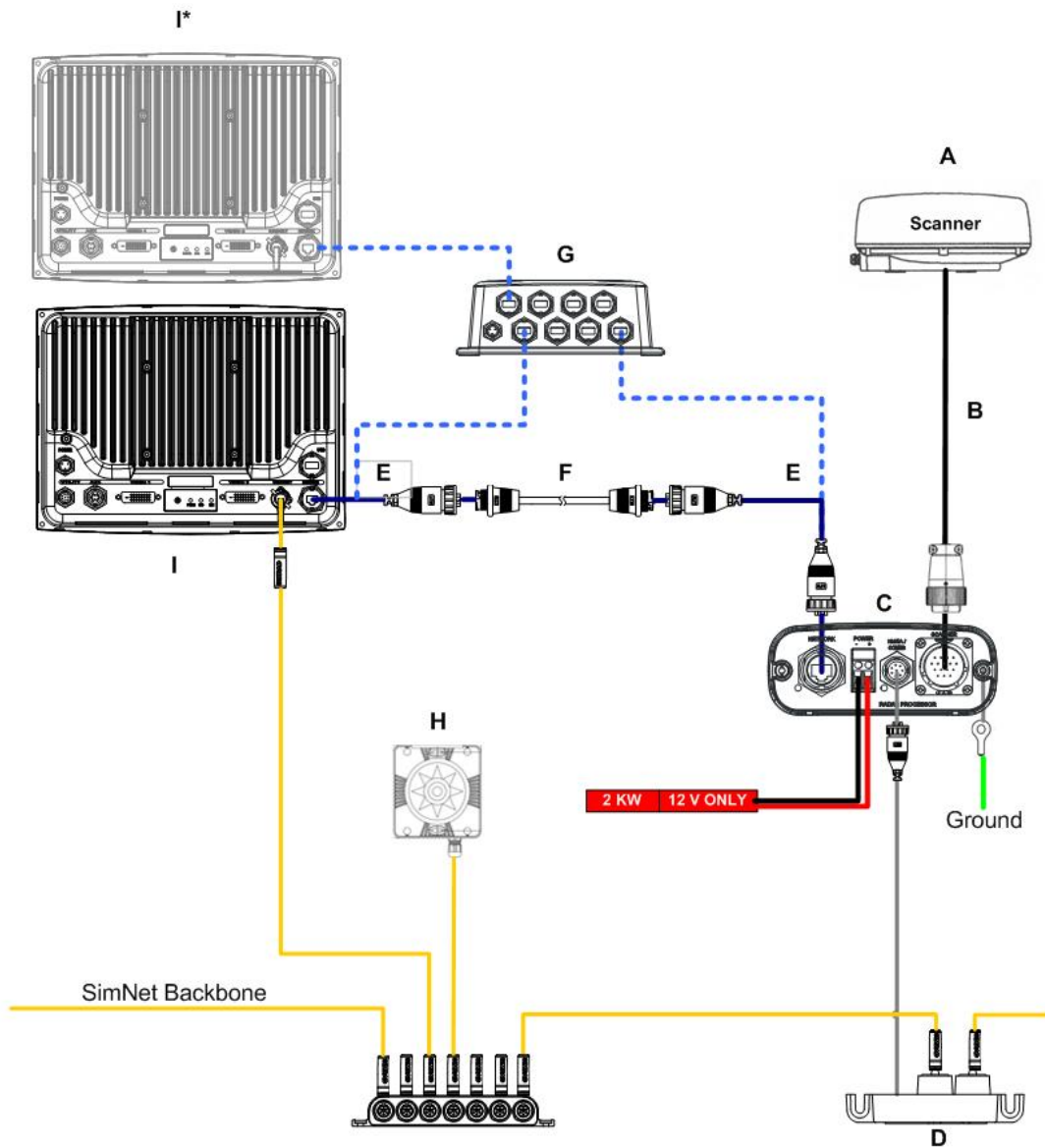

### 5.3 Northstar 8000i / Simrad GB40 using a NMEA 0183 heading sensor

The diagram below shows how to connect the radar to a Northstar 8000i or Simrad GB40 system for vessels that use a NEMA 0183 heading sensor.

For key information

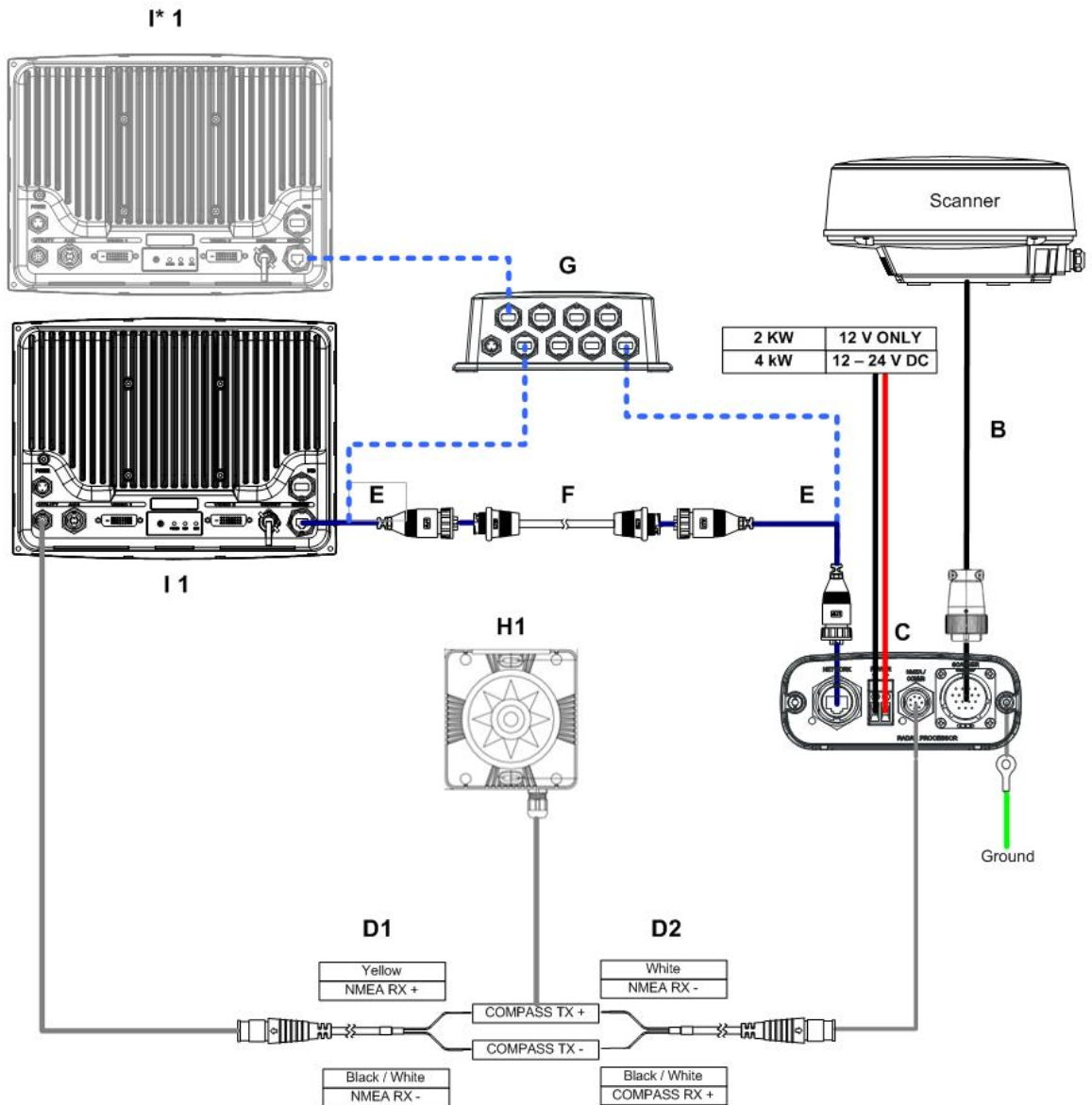

The compass must be NMEA compliant and configured as follows:

- 10 Hz update rate
- 4800 baud

The compass must be able to supply the NMEA 0183 HDT, HDM, and HDG heading sentences (all other sentence types will be ignored).

The NMEA compass must be directly connected to the 8000i / GB40 through the Utility port and the radar processor through the NMEA/COMMS port.

Compass data is appended to the radar data by the radar processor and then broadcast over the network to the 8000i or GB40 displays and other devices. This enables more precise radar chart overlay and target tracking (MARPA).

The NMEA compass cable is not supplied but the pinout of the NMEA/COMMS port is shown for information:

	Pin	Function
	3	NMEA TX+ data
	4	NMEA Ground
	5	NMEA Rx-data
	6	NMEA RX+ data
	9	Shield
	11	12 V Compass power (100 mA max)

It is recommended that a single compass data source is used for a 8000i network.

Key	Part No.	Description
A	2 kW AA010024 4 kW AA010025	2 kW scanner comes with a 15 m (49 ft) cable attached. (B) 4 kW scanner comes with a 15 m (49ft) cable that will need to be connected to the scanner. Cable from Scanner connects to Radar Processor box. An optional longer cable is available but only up to 20 m (65.5 ft).
B	2 kW AA010089 4 kW AA010091  	Optional 20 m (65.5 ft) scanner cable. Will require disassembly of dome to connect this replacement cable. Cable has radar processor connector on one end, and three small terminated flat connectors on the other. CAUTION: This cable should only be installed by an experienced radar service technician!
C	2 kW AA010012 4 kW AA010013	Radar processor module. No cables supplied. Connects to GB40 system via Ethernet. The radar box requires heading @ 10 Hz. For vessels using NMEA 0183, order cable AA010070 to connect to a suitable heading sensor. 2 kW system is 12 V DC ONLY 25 W max. Power connects to the two screw terminals. 4 kW system is 12 or 24 V DC
D	24006694	AT10HD SimNet to NMEA 0183 converter converts SimNet heading to 0183 @ 10 Hz to allow for accurate MARPA and overlay. Has two SimNet ports to sit on SimNet Bus and a 2 m (6 ft) cable terminating with 12 pin female connector. This plugs into socket labeled NMEA / COMMS on the radar processor box.
D1	AA010070	Utility cable 2 m (6 ft) with 12 pin female connector on one end and 12 bare wires on the other. This plugs into socket labeled Utility on the 8000i or GB40 Master NavComputer. This cable is shipped with each NavComputer.
D2	AA010070	Same cable as D1 but uses different colours. Cable needs to be ordered separately. Connects to the radar processor labeled NMEA / COMMS.
E	AA010079	Ethernet cables: All ethernet cables need to be ordered. They are not supplied with any product. They are available in four lengths as well as self terminating bulk rolls  Ethernet cable 0.5 m (1.6 ft) male / male connectors

	AA010080	Ethernet cable 2 m (6.5 ft) male / male connectors
	AA010081	Ethernet cable 5 m (16.5 ft) male / male connectors
	AA010082	Ethernet cable 10 m (30 ft) male / male connectors
	AA010083	Ethernet cable joiner 0.5 m (1.6 ft) female / female
	AA010086	Ethernet cable bulk roll 100 m (328 ft) un-terminated
	AA010087	Ethernet cable bulk roll 300 m (985 ft) un-terminated
	AA010085	Ethernet connector. Field terminating ethernet connector for bulk ethernet cable
F	AA010084	Ethernet cross-over joiner cable 0.5 m (1.6 ft) female / female. This can be used to connect no more than 2 network devices together e.g a radar processor and a GB40 NavComputer. The cable has female connectors at each end. Two standard ethernet cables are required to link to network devices. Connector ends are red in color. Tip: When deciding which standard ethernet cables to order, locate the crossover joiner where logically a network linker could be placed in the future if the system was upgraded. If more than 2 ethernet devices are going to be used please use the Navico 8 Port Linker (see G).
G	AA010009	Navico 8 port ethernet linker: Used to connect more than two ethernet devices together. Ships with power cable only. Order ethernet cables additionally. 12 / 24 V DC
H	22090195 or 22090187	RC42 heading sensor (or use SimNet heading output from and autopilot) or FC40 Fluxgate Compass
H 1	22084446	RC37 race compass or heading sensor with 10 Hz output. Note: Make sure the heading sensor shares the same ground as the NavComputer
I		Simrad GB40 NavComputer
I*		Simrad GB40 NavComputer second station
I 1		Northstar 8000i or Simrad GB40 NavComputer Master
I* 1		Northstar 8000i or Simrad GB40 second station

## 5.4 Setup the radar with the GB40 or 8000i

Starting up the Radar



***When commissioning the Navico radar, leave the unit on Standby for 20 minutes before transmitting. This makes sure the magnetron reaches optimum operating temperature, extending the lifetime and aiding the auto tune function. Normal use afterwards only requires the standard standby count down.***

- Select **Radar** on your OP30 controller or touch screen (8000i),
- **Radar Mode** shows the current radar mode.
- Select **Radar Mode** to display an option list:

Transmit

If the radar was in **Standby** mode, it will start transmitting immediately.

If the radar was **Off** there will be a pause of 90 - 180 seconds while the radar warms up before it starts transmitting.

## Standby

This stops transmission, but keeps the radar ready to transmit again.

## Off

This saves on power consumption (but you must turn it on and wait for the radar to warm up before you can use it again).

The radar transmits until you change the radar mode to **Standby** or **Off**.

## Set Radar Range offset (trigger delay)

The radar sweep should commence at your vessel (a radar range of zero). You may need to adjust the radar range offset to achieve this. (The radar range offset is also known as the trigger delay.)

If this is set incorrectly, a large dark circle in the center of the sweep might occur. You might notice straight objects such as straight sea walls or piers having curves or an indentation. Objects close to your vessel may appear "pulled in" or "pushed out". To rectify this, adjust the radar range offset using either the straight line or the circle method.

To adjust the radar range offset using the straight line method:

- Position the vessel about 45 m to 100 m (50 yards to 100 yards) from a straight-walled jetty or similar feature that produces a straight line echo on the display.
- Select the 1/8 mile range.
- Adjust the gain setting until a reasonably good image of the jetty echo is displayed.
- Adjust the radar range offset to make the jetty echo appear as a straight line on the display, as shown:

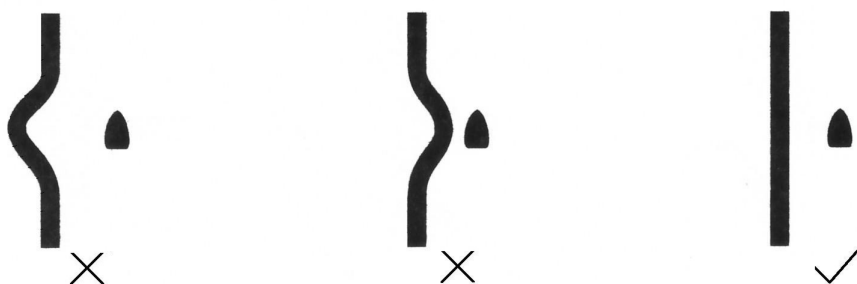

OR

To adjust the radar range offset using the circle method:

If it is not possible to position the vessel near a suitable target, perform a rough set up of the range offset by using the circle at the center of the radar screen as a guide.

If your **Radar** screen has:

- A wide black circle around the center with no echoes, increase the radar range offset until it almost disappears.
- No black circle at the center but center is covered with echo, decrease the radar range offset until a black circle just starts to appear at the center.

To change the radar range offset:

- Display the **Radar** screen and main menu. If you can't see the **Adjust Radar** button, select **Return**.
- Select **Adjust Radar**, then select **Installation**.
- Select **Radar Range Offset** then use **Up** and **Down** to adjust the current setting.
- Select **OK** to confirm the new setting.

## Change the radar bearing alignment

Use the radar bearing alignment to rotate **Radar** image, one degree at a time, so that a known object dead ahead is directly under the vessel's heading marker.

This means that the **Radar** image is aligned with the displayed chart and the compass. An accurate bearing alignment is particularly important when the radar image is overlain onto the chart.

It's best to do this on a page showing a **Chart** screen with the radar overlay on in one pane and a **Radar** screen in the other pane.

To change the radar bearing alignment:

- Select **Pages**. If you:
  - don't have a page that shows the **Radar** screen in one pane and the **Chart** screen in the other pane, edit or create a page that shows these two screens.
  - do have a page that shows the **Radar** screen in one pane and the **Chart** screen in the other, select it.
- Check that the **Chart** screen has the Radar Overlay turned On.
- Select the **Radar** pane so that it becomes the active pane. If you can't see the **Adjust Radar** button, select **Return**.
- Select **Adjust Radar**, then select **Installation**.
- The **Bearing Alignment** button shows the current setting. Select it to change the setting. Use the **Up** and **Down** buttons to move the radar image one degree at a time, until the radar overlay is aligned with the chart.
- Select **OK**.
- Select **Return**.

Other radar settings

To enter radar setup options:

- Select **Pages**, then **Setup** from the main menu.
- Select **+ Radar** to display a list of options.

<b>-Radar</b>	<b>Default</b>	<b>Installer defined</b>	<b>Description</b>
---------------	----------------	--------------------------	--------------------

### **Radar Antenna Height**

(Small Distance Units)	4 m/13.12 ft		<i>Sets the antenna height above the water-line so that the sea clutter control works properly.</i>
------------------------	--------------	--	---

### **Radar Open Array Parking Angle**

(Deg)	0		<i>Sets the angle that the radar scanner will come to rest.</i>
-------	---	--	---

### **Radar Power on Action**

Standby	X		<i>When powered, the radar will warm up, then go into standby mode.</i>
Remain Off			<i>When powered, the radar will remain off.</i>

### **Radar Information**

switch			<i>Displays magnetron hours information for the 10 kW and 25 kW scanners.</i>
--------	--	--	---



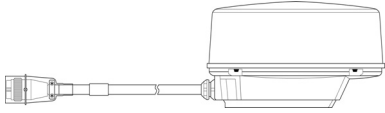
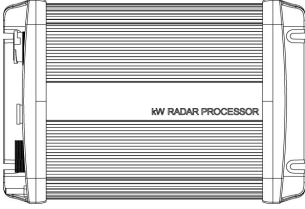

- Select **Return**.

## 6 Connect Simrad NX40 / NX45, Northstar M84 / M121

### 6.1 Parts needed NX40/45 and M84/M121

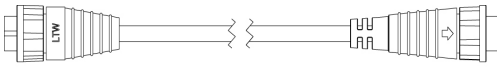
Qty.	Item	Description	Part No.
1		Scanner unit with interconnection cable 2 kW or 4 kW	For scanner part numbers (see "Check the radar parts" page 10)
<b>Radar Processor</b>			
Qty.	Item	Description	Part No.
1		2 kW Radar Processor 4 kW Radar Processor	AA010012 AA010013

If you're connecting the radar to a Simrad NX40/NX45 or a Northstar M841 or M121, you need the AA010112 connection kit or serial connection cable AA010114 (NX40/45 with heading via SimNet). These are not supplied as standard and must be ordered separately.

<b>Radar connection kit AA010112</b>			
Qty.	Item	Description	Part No.
	Radar connection kit		AA010112
1		HD Radar serial comms cable 3 m (9.75 ft)	AA010114
		Radar processor heading sensor/display Y cable	AA010113
		Radar processor NMEA in cable 250 mm (9.75")	AA010116
			

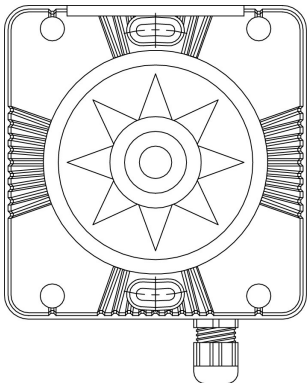

Heading sensor (optional)			
Qty.	Item	Description	Part No.
1		FC40 Fluxgate Compass OR RC42 Rate Compass. These have a 5.5 m (18 ft) SimNet cable attached. Connect using the radar accessories kit. Alternatively use an NMEA 0183 heading sensor and connect via display unit power cable.	22090187  22090195

## 6.2 Simrad NX40/45 Northstar M84/M121 radar connections

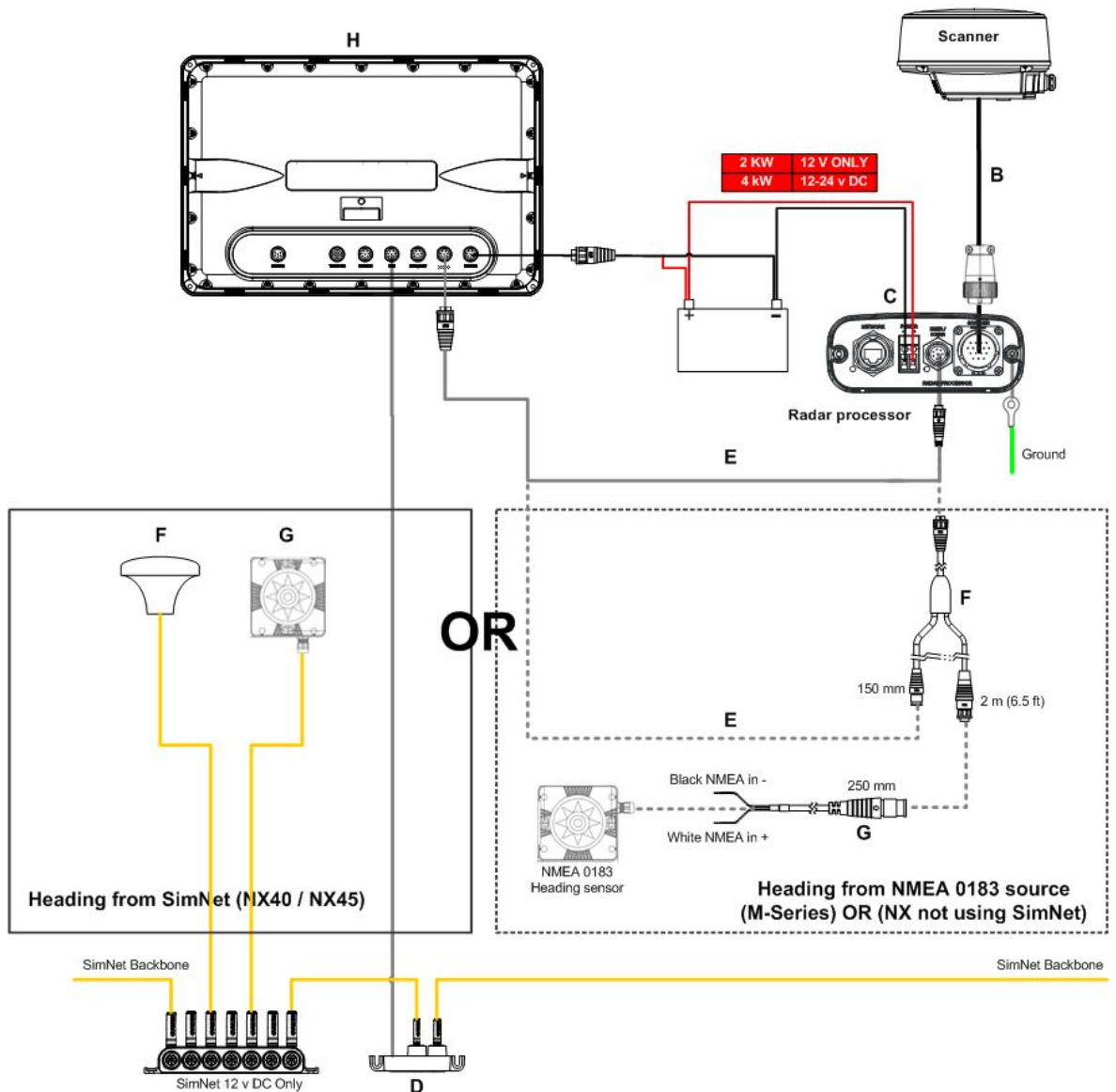

A	For scanner part numbers (see "Navico radar part numbers" page 75)	2 kW scanner comes with a 15 m (49 ft) cable (B) attached. 4 kW scanner comes with a 15 m (49 ft) cable (B) which will need to be connected
B	2 kW AA010089 4 kW AA010090	Optional 20 m (65.5 ft) scanner cable . Will require disassembly of scanner to connect. Cable has a radar processor connector on one end, and three small terminated flat connectors on the other.  CAUTION: This cable should only be installed by an experienced radar service technician!
C	2 kW AA010012 4 kW AA010013	Radar processor. No cables supplied. Connects to displays via RS485 protocol, using optional radar connection cable kit. The 2 kW system is 12 V DC ONLY 25 W max. The 4 kW is 12-24 V DC
D	AA010150 AA010169	AT40 SimNet to NMEA0183 converter. Supplied with NX40. AT45 SimNet to NMEA0183 converter. Supplied with NX45.  Converts SimNet data to NMEA 0183. Data from the SimNet such as position and heading is passed into the NX unit to allow for accurate chart overlay. Note: If there is no heading sensor on SimNet, chart overlay can be achieved when the boat is underway and moving at a speed greater than 1 knot.  The AT40/AT45 has two SimNet ports and a 2 m (6 ft) cable terminating with 8 pin female connector. This plugs into socket labeled GPS on the NX40 NX45 display.
<b>AA002461 HD Radar Connection Kit</b>		
E	AA010114	HD radar serial comms cable 3 m (9.8 ft):  This cable connects the NX display unit to the radar processor. The cable has a 8 pin female connector on one end which attaches to the port labeled RADAR on the NX unit. The other end has a 12 pin female connector which connects to the port labeled NMEA / COMMS on the radar processor
F	AA010113	Heading sensor Y cable, optional method:  Single end has a 12 pin female which connects to HD radar processor port labeled NMEA /COMMS.  Connector 1 has a 12 pin male. Cable E connects to this then to the NX display.  Connector 2 has a 8 pin male and connects to cable G which terminates in bare wires.
G	AA010116	NMEA Receive Cable, optional method:  250 mm has an 8 pin female that connect to the cable F. The other end has bare wires. Black is NMEA IN negative. White is NMEA IN positive. This connects to the NMEA 0183 heading sensor (NMEA out). A junction box may be required.
F	700-4100-001	Navico GS10 SimNet GPS antenna. Can ship with NX unit depending on part number of display (see below).  The antenna has a 5 m (16.5 ft) SimNet cable attached.  Installation note. The SimNet backbone needs to be planned to go within a 5 m cable run of the antenna.
G	22090195	RC42 Heading sensor (or use SimNet heading output from an autopilot). A heading sensor is optional when using an NX. If there is no heading sensor, course over ground from the GPS is used.
H		Simrad NX40 or NX 45 or Northstar M84 or M121.

## 6.3 Set up the radar with the Simrad NX40/45 or Northstar M84/M121

When the radar is enabled, it will turn on, warm up, and enter standby mode.

To enable the radar functionality:

- Press Setup (NX) or menu twice to display the Setup menu, then select system
- Set Radar to .
- The radar immediately turns on and enters warm-up mode. A message shows how long this will take.

When the warm-up period is complete, the radar enters standby mode and is ready to transmit.

- Select Installation:

### Zero bearing

Use the zero bearing alignment to rotate the radar image, one degree at a time, so that a known object dead ahead is directly under the boat's heading marker.

This means that the radar image is aligned with the displayed chart and the compass. An accurate bearing alignment is particularly important when the radar image is overlaid onto the chart.

Adjust this on a chart window with the radar overlay on.

- Select Zero bearing then use the arrow keys to enter the new bearing angle.

### Zero range

The zero range is also known as the radar range offset and as the trigger delay.

If your radar window shows a blank, black circle around the centre or a solid circle of color at the centre, you need to adjust the zero range setting until this circle disappears or almost disappears. Ideally, the radar sweep should start at your boat (a radar range of zero).

To adjust the zero range setting:

- Position the boat about 45 to 90 m (50 to 100 yards) away from and parallel to a straight-walled jetty or similar feature.
- Adjust the gain setting if necessary, so that a reasonably good image of the jetty echo is displayed on the radar window. At this stage, the jetty echo may appear to be bent.
- Select Zero range then use the arrow keys to adjust the zero range setting until the jetty echo appears as a straight line on the radar window.

### Antenna height

- Select Antenna height then enter the height of the antenna above sea level.

## 7 Connect Northstar 6000i / 6100i

### 7.1 Parts needed to connect to a Northstar 6000i / 6100i

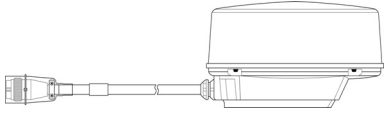
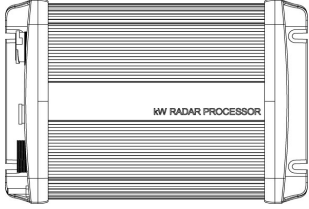
Qty.	Item	Description	Part No.
1		Scanner unit with interconnection cable 2 kW or 4 kW	For scanner part numbers (see "Navico radar part numbers" page 75)
Radar Processor			
Qty.	Item	Description	Part No.
1		2 kW Radar Processor 4 kW Radar Processor	AA010012 AA010013

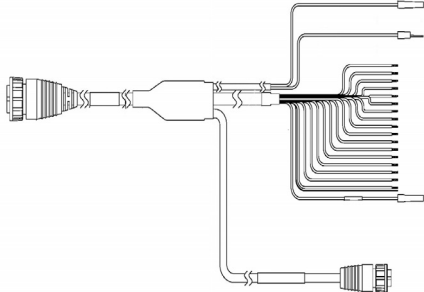
NS003107 cable for 6000i and 6100i installations only - supplied with 6000i and 6100i system			
Qty.	Item	Description	Part No.
1		Radar communications cable	NS003107

NS003108 Optional extension cable for 6000i and 6100i installations only - order separately			
Qty.	Item	Description	Part No.
1		Radar communications extension cable	NS003108

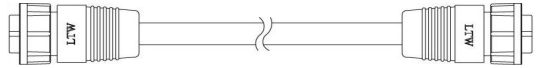
Serial comms extension cables + adapter			
Qty.	Item	Description	Part No.
1		16.4 ft (5 m) extension and adapter 49.25 ft (15 m) extension and adapter	AA002430 AA002432

## 7.2 Connect the radar processor to a 6000i or 6100i display

The following diagram shows the recommended method for connecting a radar processor to a Northstar 6000i or 6100i display unit:

If you are connecting the radar to a Northstar 6000i or 6100i system, a 10 ft (3 m) radar communications cable (NS003107) is supplied with the 6000i or 6100i system. If this is not long enough, an optional 6 ft (1.8 m) extension cable (NS003108) can be added between the radar processor and the 6000i. This extension cable is not supplied as standard, and must be ordered separately.

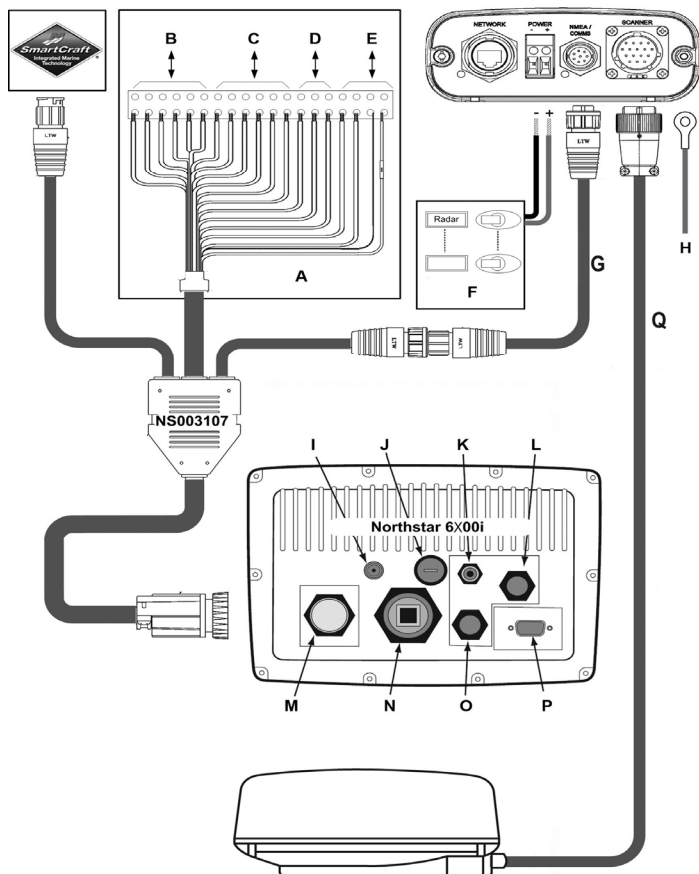

B	To NMEA Device 1
C	To NMEA Device 2
D	To Smartcraft
E	Remote power
F	Circuit breaker/fuse box
G	Optional radar communications extension cable (NS003108)
H	Vessel's Ground
I	NTSC Video Input
J	Fuse (7A)
K	GPS antenna
L	Power
M	NMEA
N	Ethernet
O	AUX
P	VGA (out)

## 7.3 Connect the radar communications cable (NS003107) to the junction box

The radar communications cable (NS003107) splits the 14 pin connector of the 6000i/6100i into (three) 3 different connectors, Bare Wires, Radar Comms and SmartCraft. This cable allows the 6000i/6100i to connect to NMEA devices (Bare Ends) or to Navico digital radar (Connector 1) or to a SmartCraft junction box (connector 2).

The output of the internal wires of the cable are in some cases duplicated, for example, pin 6 on the connector ends the white/brown bare end and the pin 1 of the radar comms connector. It is critical that the connector pins sharing multiple outputs such as pin 6 not be connected at the same time to different devices. i.e. If you are connecting a 6000i/6100i to the Navico radar processor box you must not connect any other device to the bare ends White/Brown, Brown/White, Yellow, Orange, Black, Orange/White and Drain.

The free ends of the radar communications cable (NS003107) must be terminated in a junction box or isolated from each other (see the figure in the previous section). The junction box is not supplied.

The communications cable has a 0.41" (10.5 mm) diameter. The junction box must be waterproof and large enough to contain a 20 way strip connector.

All cable entry points should use suitable grommets or glands to ensure that waterproofing is maintained.

The table shows the wiring and pin details of the radar communications cable. The naming convention for the bi-colored wires is primary color/stripe; for example, White/Orange refers to a white colored wire with an orange stripe.



**\* DO NOT connect the bare wires if the radar comms (connector 1) is connected to the radar processor box**

**\*\*DO NOT connect these bare wires if the SmartCraft (connector 2) is connected to the SmartCraft gateway**

NMEA devices must be connected to an unused NMEA port on the connector strip.

The remote power signal configuration is explained in "Configure the remote power control for a 6000i or 6100i (common power source)" and "Configure the remote power control for a 6000i or 6100i (different power sources)".

Wire function	6000i/6100i connector PIN		Bare wires	Radar comms (connector 1)		SmartCraft (connector 2)	
	PI N	Color	Color	Pin	Color	Pin	Color
NMEA 1 IN A	3	Brown	Brown				
NMEA 1 IN B	1	Blue	Blue				
NMEA 1 IN GROUND	4	White/Blue	White/Blue				
NMEA 1 OUT A	12	Violet	Violet				
NMEA 1 OUT B	7	Gray	Gray				
NMEA 1 OUT GROUND	8	Blue/White	Blue/White				
NMEA 2 IN A	6	White/Brown	White/Brown *	1	Green		
NMEA 2 IN B	2	Brown/White	Brown/White *	2	Red		
NMEA 2 IN GROUND	5	White	White *				
NMEA 2 OUT A	15	Yellow	Yellow *	7	Orange		
NMEA 2 OUT B	11	Orange	Orange *	8	Blue		

NMEA 2 OUT GROUND	10	Black	Black	12	Yellow		
RS-232 GROUND	17	Tan	Tan			1	White
RS-232 RX	16	Green	Green **			3	Green
RS-232 TX	18	Red	Red **			8	Red
REMOTE SAVE	13	Orange/White	Orange/White				
6000i or 6100i REMOTE POWER OUT	14	Pink	Pink				
SHIELD	9	Drain	Drain	9	Drain		
RADAR REMOTE POWER IN		White/Orange		10	Brown		

\* See cautions above.

\*\* See cautions above.

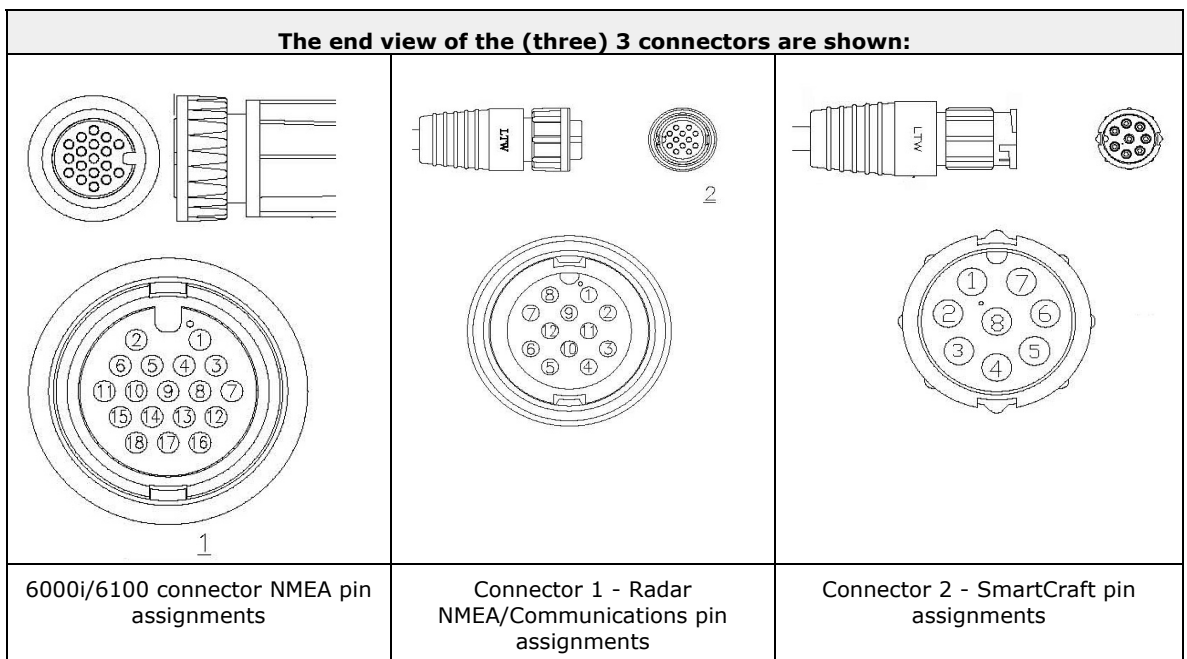

## 7.4 Configure the remote power control for a 6000i or 6100i (common power source)

There is a choice of two different modes for powering the radar ON/OFF:

### Power on Option 1

- If you want the radar to power ON automatically whenever the 6000i or 6100i is powered ON, program the Honk Output as REMOTE PWR in the 6000i or 6100i. This option is contained in the Alarms menu. (To access the Alarms menu, repeatedly press the \* key until the Alarms menu is visible.) You must also connect the Pink wire (Pin 14) to the White/Orange wire (Pin 13) in the junction box.

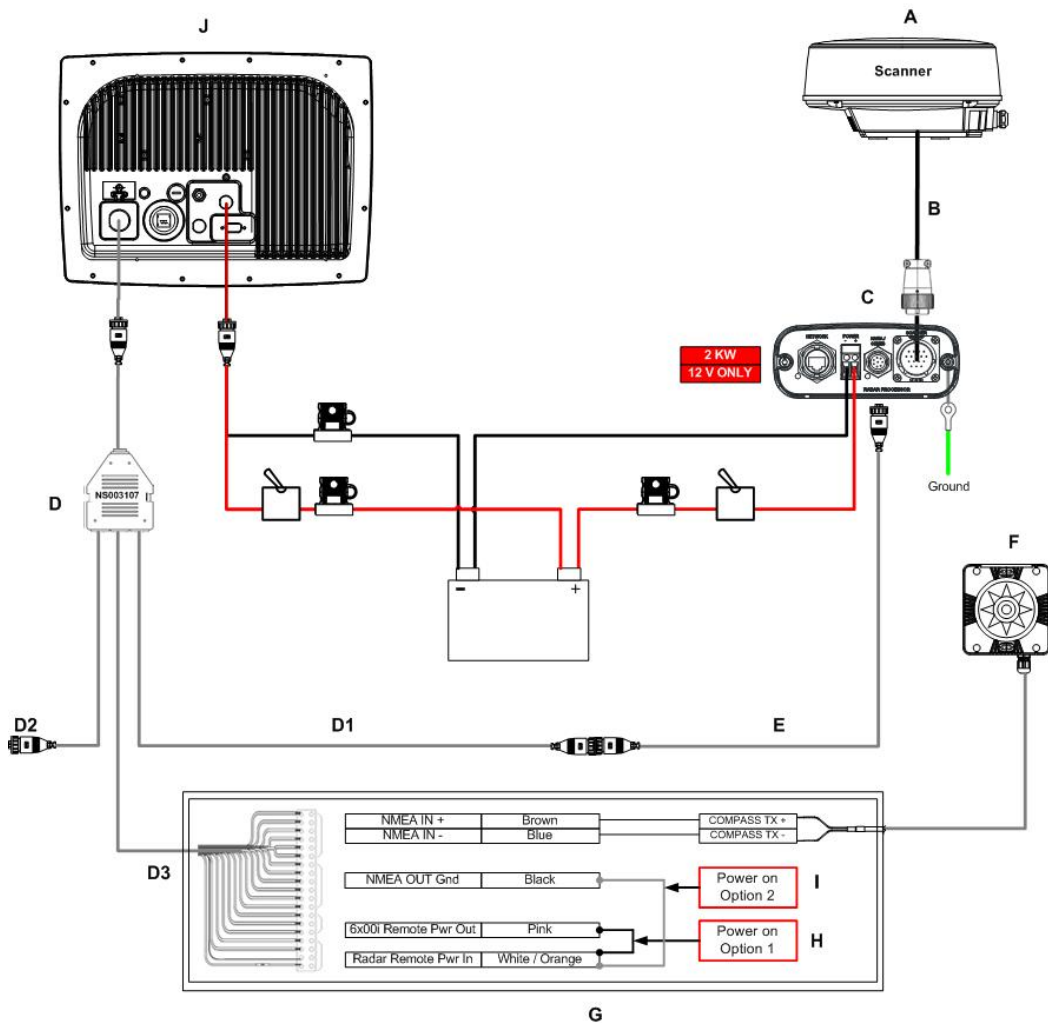

### Power on Option 2

- If you want the radar to power ON automatically when the radar processor is powered ON, connect the White/Orange (pin 13) wire to a Black NMEA 2 ground (pin 10) in the junction box.

*Important: This remote power control option works correctly only when the 6000i or 6100i and the radar processor share the same power earth and are located within 16.5 ft (5 m) of each other.*



## 7.5 Configure the remote power control for a 6000i or 6100i (different power sources)

When the 6000i or 6100i and the radar processor have isolated power supplies, or are located more than 16.5 ft (5 m) apart, there is a choice of two different modes for powering the radar ON/OFF:

- If you want the radar to power ON automatically whenever the 6000i or 6100i is powered ON, use the following power ON/OFF configuration:

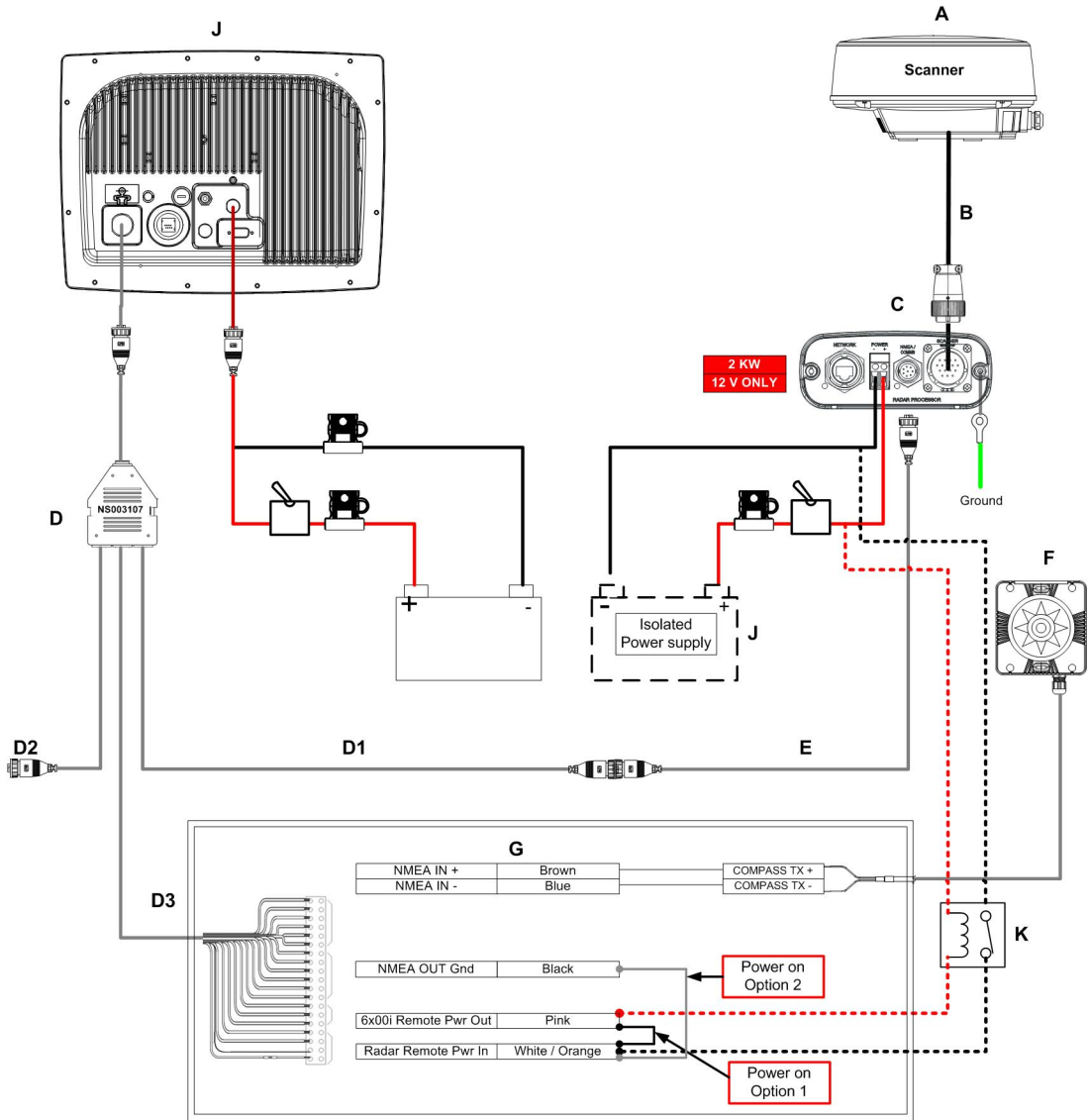

If you want the radar to power ON automatically when the radar processor is powered ON, omit the relay and leave Pin 10 and 12 on Connector 1 (the NMEA/COMMS connector) as No Connect.

Key for above two drawings

A	AA010024NOR	2 kW scanner comes with 15 m (49 ft) cable attached. Cable from Scanner connects to Radar Processor box. An optional longer cable is available but only up to 20 m (65.5 ft).
B	AA010089 	Optional 20 m (65.5 ft) scanner cable. Will require disassembly of dome to connect this replacement cable. Cable has radar processor connector on one end, and three small terminated flat connectors on the other. CAUTION: This cable should only be installed by an experienced radar service technician!
C	AA010012	2 kW radar processor box. No cables supplied. Connects to 6x00i system via RS422. The radar box requires heading @ 10 Hz. For vessels with SimNet heading, use an AT10HD (see D) SimNet NMEA 0103 converter. Ethernet cables need to be ordered (see E). 2 kW system is 12 V DC ONLY 25 W max. Power connects to the two screw terminals.
D	NS003107	Radar and communications cable 3 m (9.6 ft) included with 6x00i.
	D1	Radar Connection cable 0.5 m (1.6 ft) 12 pin female. Connects to the radar processor port labeled NMEA / COMMS or can be extended using optional NS003108 (E).
	D2	Smartcraft Gateway interface (optional) 0.5 m (1.6 ft) 8 pin male.
	D3	NMEA / RS232 / Remote power on cable 0.5 m (1.6 ft) terminating in bare wires. All unused wires must be isolated from each other.
E	NS003108	Radar and communications extension cable 3 m (9.6 ft).
F		RC37 heading sensor or third party NMEA 0183 heading sensor which can output heading at greater than 10 Hz.
G		Junction box (not supplied).
H		Power on option 1
I		Power on option 2
J		NS6000i / 6100i display head (master display on a multi-display system).
K	Relay	Power on option 3 used when 6x00i and radar processor have isolated power supplies or are located more than 5 m (16.5 ft) apart.

## 7.6 Set up the radar with the Northstar 6000i or 6100i

### 7.7 Turn the radar on and off

#### Before you turn on the radar for the first time

To extend magnetron lifetime, you're recommended to leave the radar in Standby mode for 30 minutes when activating the radar for the VERY FIRST time. (When the radar is in Standby mode, it's NOT transmitting but it is powered up – this allows the magnetron heater to stabilize). Then, after 30 minutes, press the RADAR ON key to test and align.

If you are using the radar with the 6000i or 6100i, press CLR (NOT ENT) the VERY FIRST time when the radar transmit activation message appears. After this first time, you can press ENT anytime this screen appears. If the radar has not already warmed up, the radar countdown timer will appear – typically 90 seconds on lower powered radars – then the radar will automatically start transmitting.

#### Turn the radar on

*IMPORTANT: Do not use the navigator's Demo Mode when the radar is switched on.*

Several menu buttons on the radar display must be activated before the adjustment they control can be changed. Here's how they work:

- any button displayed in red is already active. Press it, or use the keypad or cursor controls to adjust the value.
- any button displayed in blue is inactive. Press it once to activate it.

The radar normally provides a good picture when used in its automatic modes described in "Configure the navigator". In many cases, the picture can be improved by using the Range Rider mode.

Before turning ON the radar for the first time to set it up, check that the vessel's DC primary power supply is within the recommended range of 10.8 V to 16 V for a 12 V system, or 21.6 V to 32 V for a 24 V system.

Check that everyone is outside the radiation hazard area and any rotation hazard area.

Turn ON the radar as follows:

- Turn ON the radar processor by installing the fuse or by turning ON the circuit breaker to the radar system.
- Turn ON the navigator (display) unit. The power switch is on the front panel.

Turn the radar off



***Be sure to turn the scanner OFF before servicing the scanner or working in the vicinity of a rotating open array.***

***Turn the radar OFF by removing the fuse or by switching OFF the radar's dedicated circuit breaker.***

***Depending on the power switch configuration, the radar may automatically turn OFF when the navigator (display) unit is turned OFF.***

## 7.8 Configure the navigator communications

*IMPORTANT: If you are going to operate the radar without a heading sensor, ignore this section and set up the radar as described in "Disable the header sensor input".*

To enable the radar to communicate with the navigator, set up the radar option on the navigator's PORT 2 SETUP screen as follows:

- Press **STAR** several times to display the OPTIONS/SERVICE INFO screen.
- Press **Port Setup Options**.
- Press **Port 2 Setup** and use the **Cursor Pad** to select the **Output Format** line.
- Press **Edit**, then use the **Cursor Pad** to select **Radar**.
- Press **Enter**. The change is made immediately and you do not need to restart the navigator.

## 7.9 Adjust the appearance settings

The Mode, Rain Clutter, Sea Clutter and Gain are usually set to automatic mode to obtain an excellent image under most conditions and, by default, allow you to see any approaching weather rain cells for maximum safety. However, these settings may need minor adjustments depending on the location of the radar.

To access these controls, press **Page 2** from the main radar screen.

- The **Mode** key determines how the gain and clutter keys work. It has the following settings:
  - **Auto 1** and **Auto 2** are for normal, open-water conditions. The two automatic modes can be optimized for two different conditions.
  - **Harbor** automatically optimizes the radar settings for use in a harbor. This is the default setting.
  - **Range Rider** is a Navico exclusive feature recommended for use when manual settings are required. You can make changes to the clutter and gain settings for different ranges, and the Range Rider will store these settings for each range. Then, when you select a particular range again, the settings are already optimized.
  - **Manual** is a fully manual function in which you will usually need to adjust the settings manually each time you change the range.

Gain and Sea Clutter appearance settings are available in Auto1, Auto 2 and Harbor modes.

These can be accessed by pressing the Gain or Sea Clutter buttons while in Auto1, Auto 2 or Harbor mode with Gain or Sea Clutter set to Auto.

The default appearance setting is 25 for both Gain and Sea Clutter for all ranges.

The appearance settings can be adjusted between 0 and 50. This represents a +/- 25 step offset away from the nominal Auto mode setting. The value set will be applied only to the current range.

## 7.10 Heading sensor requirements

The heading sensor can be a stand-alone unit or may be integrated into an auto-pilot system, provided that it supplies the NMEA 0183 HDG, HDT, OSD, HCC, HCD or HDM heading sentences to the navigator. It must output data at a 10 Hz update rate.

If the heading sensor requires sea trial calibration, perform the manufacturer's recommended calibration procedure before you calibrate the radar heading.

Heading calibration should be performed during initial setup, annually, and after any major structural changes to the vessel.

The Northstar 6000i and 6100i accepts the following standard NMEA 0183 sentences from a heading sensor (such as the Simrad RC37 Rate compass) to obtain the following heading information: HDG, HDT, OSD, HCC, HCD, and HDM.

For sensor installation and calibration instructions, see the sensor manufacturer's Installation Manual. In addition, the navigator must be calibrated to the heading sensor (see "Set the heading calibration (heading sensor installed)" page 53) and, for a 6000i or 6100i system installation also see "GM6KIM Rev D (6000i Installation Manual)" or the new "MN000320A Northstar 6000i & 6100i Installation Manual"

## 7.11 Disable the heading sensor input

The heading sensor is configured by default when the navigator is configured for radar.

If a heading sensor is NOT installed and connected, you must remove its configuration as follows:

- Turn on the navigator and wait for it to complete its power-up sequence.
- Press **RADAR** to display the radar screen on the 6000i or 6100i.
- The system asks if you want to turn on the scanner. Press **Enter** to turn it on.
- Press **Page 2, Page 3, Page 4**, and **Install...** to show the installation screen.
- Press **Hdg Sensor Installed** to change its displayed status to **No**.
- Press **STAR** to display the alarm screen, then press **Clear Alarm**. This clears the heading sensor alarm.

## 7.12 Calibrating the radar

You must calibrate the newly installed radar by adjusting the trigger delay and the heading calibration.

To evaluate medium and short range returns, you are recommended to perform the calibration at sea in a normal operating environment and under fair weather conditions. There should be an area of at least 3 nautical miles forward of the vessel, containing known targets including the coastline. A wave height of about one to two feet (half a meter) to create some sea clutter, is ideal. Do not perform the calibration in an enclosed or busy area such as a boatyard.

Attempts to tune and calibrate under less than recommended conditions may lead to substandard performance. A sea trial that allows the selection and use of all the ranges is highly desirable.

## 7.13 Prepare for calibration

Prepare for calibration as follows:

- Press **RADAR** to display the radar screen on the 6000i or 6100i.
- The unit may ask if you want to turn on the scanner. If it does, turn it on. You should see range rings displayed on the screen or the scanner warm-up countdown followed by a message saying "Radar is OFF". If nothing appears, the radar control box is not powered up or not properly interfaced to the navigator. Check the power wiring, interface wiring, and navigator communications configuration.
- Press **Page 2, Page 3, Page 4**, then **Restore...**

- Press **Restore factory settings**. (A new Northstar 6000i or 6100i is shipped with standard factory settings that are appropriate for basic operation.)
- Press **Return**.

## 7.14 Tune the radar

The Navico radar uses a fully automatic tuning procedure that continuously checks for optimum adjustment during operation. Navico recommends using auto tuning mode for normal operation. For special situations requiring manual tuning, refer to Manual tuning procedure for the 6000i or 6100i system (see "Manual tuning procedure for the 6000i or 6100i system" page 55).

Tune the radar so that the radar receiver frequency matches the transmitter frequency.

For normal operation of a Navico radar, you're recommended to set the tuning mode to Auto.

To tune the unit manually refer to the section Manual tuning procedure for the 6000i or 6100i system (see "Manual tuning procedure for the 6000i or 6100i system" page 55). To check the tuning mode or change it to Auto:

- Press **RADAR** to display the radar screen on the 6000i or 6100i.
- Press **Page 2, Page 3, Page 4**, then **Install...** and then **Tune...** .
- If necessary, press **Tune mode** repeatedly until it displays **Auto**.

## 7.15 Set the STC Curve

The STC (Sensitivity Time Control) attempts to compensate for the high strength of nearby echoes compared with the very much weaker echoes from distant objects. It lowers the receiver gain when the pulse is transmitted, and raises the gain as echoes return from longer distances. Ideally, the result is that all echoes are displayed with strengths proportional to the reflectivity of the objects. A graph showing the receiver gain plotted against time is called the STC curve. You can select different curve shapes, if required for special applications.

The height of the scanner affects the STC curve shape needed for the sea control to effectively reduce sea clutter. The STC curve shape corresponds to the scanner's height (in meters) above the waterline; for example, if the scanner is 20 ft (6 m) above the waterline, select STC curve 6.

Curve 4 is the default, and represents a scanner 13 ft (4 m) above the waterline.

To select a different curve:

- Press **RADAR** to display the radar screen on the 6000i or 6100i.
- Press **Page 2, Page 3, Page 4** then **Install...** and then **Tune...** .
- Press **STC Curve** then use the keypad to enter a curve number from 0 to 8.

## 7.16 Set the trigger delay

There are two methods that you can use to set the trigger delay. The two methods should produce very similar settings. Method 1 is easier to perform but Method 2 may produce more accurate results. You can use either, or both, methods.

Set the trigger delay after you have restored the factory settings (see "Prepare for calibration") OR manually turn off the Interference Rejection, Trails and Expand functions.

### Method 1

Use this method when the vessel is in open water with few or no nearby echoes.

- Display the main radar screen then press **Page 2**.
- Press zoom **Range** - several items to zoom in to the maximum magnification.
- If necessary, press **Mode** to make it read **Manual**.
- Press **Rain Clutter**, then press **0** twice to set the rain clutter value to zero.
- Press **Sea Clutter**, then press **0** three times to set the sea clutter value to zero.

- Press **Gain**, then press **1, 5, 0** to set the gain to 150. If you are using standard screen colors, the display will show a green ring with a black center or solid green circle. If it doesn't, try changing the gain value until you can see the green ring and black center clearly. (If the gain is set too high, the display may be saturated.)
- Press **Page 3, Page 4, and Install...** .
- Press **Trigger Delay**, then press **000** on the keypad to set the trigger delay to zero.
- Increase the trigger delay by pressing the Cursor Pad to the right (or enter a larger number on the keypad). The black circle will shrink as you increase the trigger delay. Set the trigger delay so that the black center just disappears, with only one or two dots remaining in the center of the display.

## Method 2

Use this method when the vessel is about 50 to 100 yards (45 to 90 m) from a straight-walled jetty or similar feature that produces a straight line echo on the display.

- Adjust the gain setting until a reasonably good image of the jetty echo is displayed.
- Adjust the **Trigger Delay** to make the jetty echo appear as a straight line on the display, as shown:

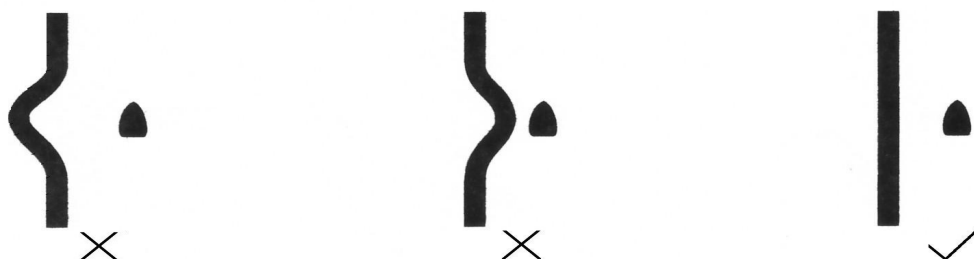

## 7.17 Set the heading calibration (heading sensor installed)

The heading calibration rotates the radar image on the screen to line it up with the displayed chart and the compass. Accurate heading calibration is particularly important when the radar image is overlain onto the chart.



*Note: Make sure the heading sensor is calibrated according to the manufacturer's recommendations.*

- When performing a sea trial of the vessel, set a straight course for a solid object such as a lighthouse, jetty or radar navigation marker that is at least 1 nautical mile distant as referenced on the chart.
- Press **CHART** to display the chart then press **Overlay** to show the radar echoes overlain on the chart.
- Set the chart rotation to North-Up by pressing **Rotate** several times until **North-Up** is displayed.
- Find a target at least 1 nautical mile distant that appears on both the chart and the radar overlay. Do not choose a beach or a buoy as a target; instead, choose an obvious land pattern or solid object with a fixed reference point such as a jetty, lighthouse, or pier.
- Zoom in as necessary to place identifiable objects near the outer edge of the screen.
- Press **Control** so that it displays **Radar**.
- Press **Page 2, Page 3, Page 4, and Install...** .
- Press **Heading Calibrate** then press the **Cursor Pad** left and right to rotate the radar image so that the radar target matches its compass heading on the chart and lines up on top of the position shown on the chart.
- If possible, check targets in all quadrants to ensure accurate adjustment.

## 7.18 Set the heading calibration (heading sensor not installed)

The heading calibration rotates the radar image on the screen so that a target dead ahead corresponds to a bearing of 0° on the screen.

- Press **RADAR** so that the navigator displays radar only.
- Find a target at least 1 nautical mile distant. Choose an obvious land target or solid object with a fixed reference such as a jetty, light house or pier. Steer the vessel until the reference target is directly head up then maintain this heading.
- Zoom in as necessary to place the reference target near the outer edge of the screen.
- Press **Page 1, Page 2**.
- Check that the chart rotation (**Rotate** button) is set to Hdg Up.
- Press **Page 2, Page 3, Page 4** and **Install...**
- Press **Heading Calibrate** then press the cursor pad left and right to rotate the radar image so that the reference target is at 0° (vertical from the centre of the radar sweep).

## 7.19 Restore all the factory settings

If you need to restore ALL of the radar settings (except trigger delay, heading calibration and whether or not a heading sensor is installed) to their factory settings, do the following:

- From the main radar page, press **Page 1**.
- Press **Restore...**
- Press **Restore factory settings** to return the unit to its state when it was shipped with the exception of the following:
  - trigger delay
  - heading calibration
  - whether or not a heading sensor is installed
  - parking calibration

This function is used before performing manual tuning (see Appendix B) or at any time it's necessary to restore the unit to a known state.

## 7.20 Restore the factory appearance settings

Appearance settings and manual settings can be restored to values that normally produce a useful picture as follows:

- From the main radar page, press **Page 1**.
- Press **Restore...**
- Press any or all of **Restore Auto, Restore Harbor, Restore Range Rider, and Restore Manual** to return to the factory appearance settings.

This completes the installation calibration.

*Note: The heading correction may need to be adjusted slightly after the gain is optimized to provide a better picture.*



## 7.21 Manual tuning procedure for the 6000i or 6100i system

*Note: The following manual tuning procedure is provided only for possible situations where the unit's automatic tuning does not perform well with a Northstar 6000i or 6100i system. At present, Navico is not aware of any such situation and recommends that automatic tuning be used, unless a reason is found to use this manual procedure.*

Begin by restoring all radar settings to their factory settings (except trigger delay, heading calibration and whether or not a heading sensor is installed), as follows:

- From the main radar page, press **Page 1**.
- Press **Restore... .**
- Press **Restore factory settings** to return the unit to its state when it was shipped (with the exception of trigger delay, heading calibration and whether or not a heading sensor is installed).
- Press **Return** and **Done** to return to the main radar screen.

Next, set the rain clutter and sea clutter to 0 and the gain to 150 as follows:

- From the main radar page, press **Page 2**.
- If necessary, press **Mode** to make it read **Manual**.
- Press **Rain Clutter** to activate the control.
- If necessary, press **Rain Clutter** again to make it read Manual.
- Press **0** twice on the keypad to set the rain clutter value to zero.
- Press **Sea Clutter**.
- Press **0** twice on the keypad to set the sea clutter value to zero.
- Press **Gain** to activate the control.
- If necessary, press **Gain** again to make it read **Manual**.
- Press **1, 5,** and **0** on the keypad to set the gain to 150.
- Press **Return** and **Done** to return to the main radar screen.

Next, set the scale to 1/8 nautical miles as follows:

- Press zoom **Range -** several times to access the 1/8 nautical miles scale. (The current scale is shown in the upper left corner of the screen, identified as "RNG").
- From the main radar page, press **Page 2, Page 3, Page 4,** and **Install... .**
- Press **Tune...** to display the tuning screen.
- Press **Tune Mode** (repeatedly if necessary) to set it to **Manual**.
- Set the rough tune value to 128 (if necessary) by selecting **Tune Preset** and typing **128** on the keypad.
- Press **Tune**.
- Adjust the tune preset value upwards by pressing the up arrow key on the cursor pad until the quantity and strength of visible targets is maximized.
- If the quantity and strength of targets does not increase, return to 128 by typing **128**. Then adjust the tune preset value upwards by pressing the down arrow key on the cursor pad until the quantity and strength of visible targets is maximized.

## 8 Connect to Lowrance Displays

The Lowrance 2 kW (LRA-1800) and 4 kW (LRA-2400) radar system is compatible with the display heads listed in Introduction to the Navico radar system (see "Introduction to the Navico radar system" page 6).

### Software Update

If your display unit's software version is less than 2.2.0, you will need to update the unit's software. To update your unit, contact your dealer or download the update from our web site, [www.lowrance.com](http://www.lowrance.com).

### More Information

For more information regarding radar operation please refer to the RIM300 Operation manual.

This section details how to connect the broadband radar to the Lowrance displays listed below. The displays connect via an RS232 connection to the scanner

### 8.1 Parts needed to connect to Lowrance displays

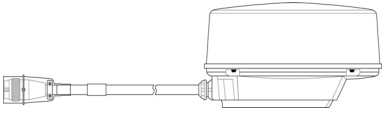
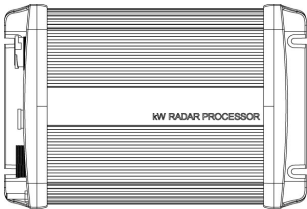
Qty.	Item	Description	Part No.
1		Scanner unit with interconnection cable 2 kW or 4 kW	For scanner part numbers (see "Navico radar part numbers" page 75)
<b>Radar Processor</b>			
Qty.	Item	Description	Part No.
1		2 kW Radar Processor 4 kW Radar Processor	AA010012 AA010013

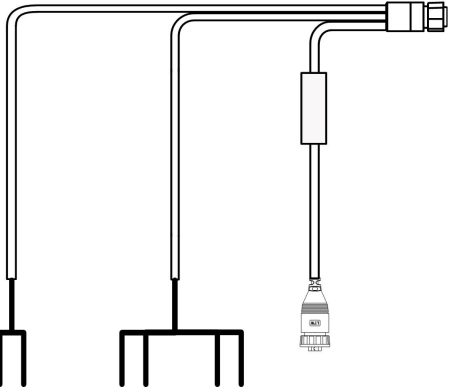
<b>RIM300 Radar Interface Module (supplied)</b>			
Qty.	Item	Description	Part No.
1		Rim 300 cable	003-7989-00

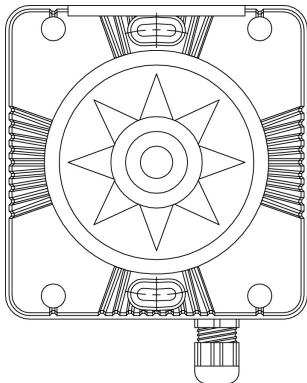
Optional Heading Sensor			
Qty	Item	Description	Part No.
1		<p>FC40 Fluxgate Compass OR RC42 Rate Compass.</p> <p>Both the FC40 and RC42 have 5 m (16 ft) SimNet cables attached.</p> <p>Connect using the SimNet to NMEA 2000 Adapter kit (000-0127-45).</p> <p>Alternatively use an NMEA 0183 heading sensor and connect via display unit power cable.</p>	<p>22090245</p> <p>22090237</p>

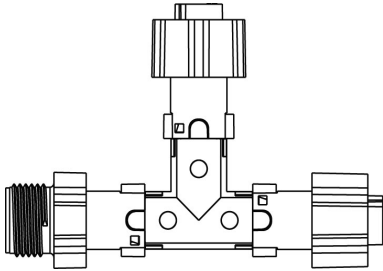
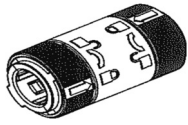
Optional SimNet to NMEA 2000 Adapter kit (000-0127-45). Used to interface the above heading sensors			
Qty.	Item	Description	Part No.
1		SimNet to Micro C	24005729
		N2K-T-RD T connector Installed into the NMEA 2000 backbone	037-0491-01
1		SimNet cable joiner	44172260

## 8.2 Lowrance displays radar connection

### RIM 300 Installation

The RIM 300 will replace the power cable that came with your display unit. Your RIM 300 has three cables branching out from the cable plug, which include: radar data cable, display unit power cable and NMEA 2000 power cable.

*Note: You will need to purchase a heading sensor for the Radar Overlay feature to work properly.*



**You MUST remove the power cable that came with your unit and replace it with the RIM 300 to complete this installation.**

***Even though the RIM 300 is replacing your original power/data cable, you must follow the same rules, cautions and warnings for powering the display unit and a NMEA 2000 network or LGC-3000 antenna module. These details are described in the display unit manual and the LGC-3000 instruction sheet. Failure to follow all power connection instructions and fusing requirements could result in damage to your equipment and injury to you. The RIM 300 radar data cable is connected to the radar processor.***

- The RIM 300 works from a 12-volt DC battery system. The display unit power cable has four wires: red, black, blue and green. You will use the red and black wires to power your display unit. Attach the red wire (+) to an accessory switch or power bus connected to a 12-volt battery. Connect the black ground wire (-) to the battery negative post.

*Important: If possible, keep the power cable away from other boat wiring, especially the engine's wires. This will provide the best isolation from electrical noise. If the cable is not long enough, splice #16 gauge wire onto it. Make sure to attach the in-line fuse holder to the red lead as close to the power source as possible.*

- The blue and green wires (Com port 2) can be used to exchange data with any NMEA 0183-compatible device. Connect the blue (TX) transmit wire to the receive (RX) wire from the NMEA 0183 device. Now connect the green (RX) receive wire to the transmit (TX) wire from the NMEA 0183 device. There is no ground wire, so the NMEA 0183 device MUST be grounded to the same source as the display unit.
- If you are powering an NMEA 2000 network or an LGC-3000 GPS antenna through the head unit, you must connect the NMEA 2000 power cable. Attach the NMEA 2000 red wire (+) to an accessory switch that is connected to the same 12-volt power source as the display unit power cable red wire (+). Be sure to use the 3-amp fuse. Connect the black wire (-) to the negative battery post.
- Plug the RIM 300 radar data cable into the NMEA/COMMS port on the radar processor box.
- After all wires and cables have been connected and all unused wires insulated, insert the RIM 300 cable plug in the power/data receptacle on the back of your display unit.

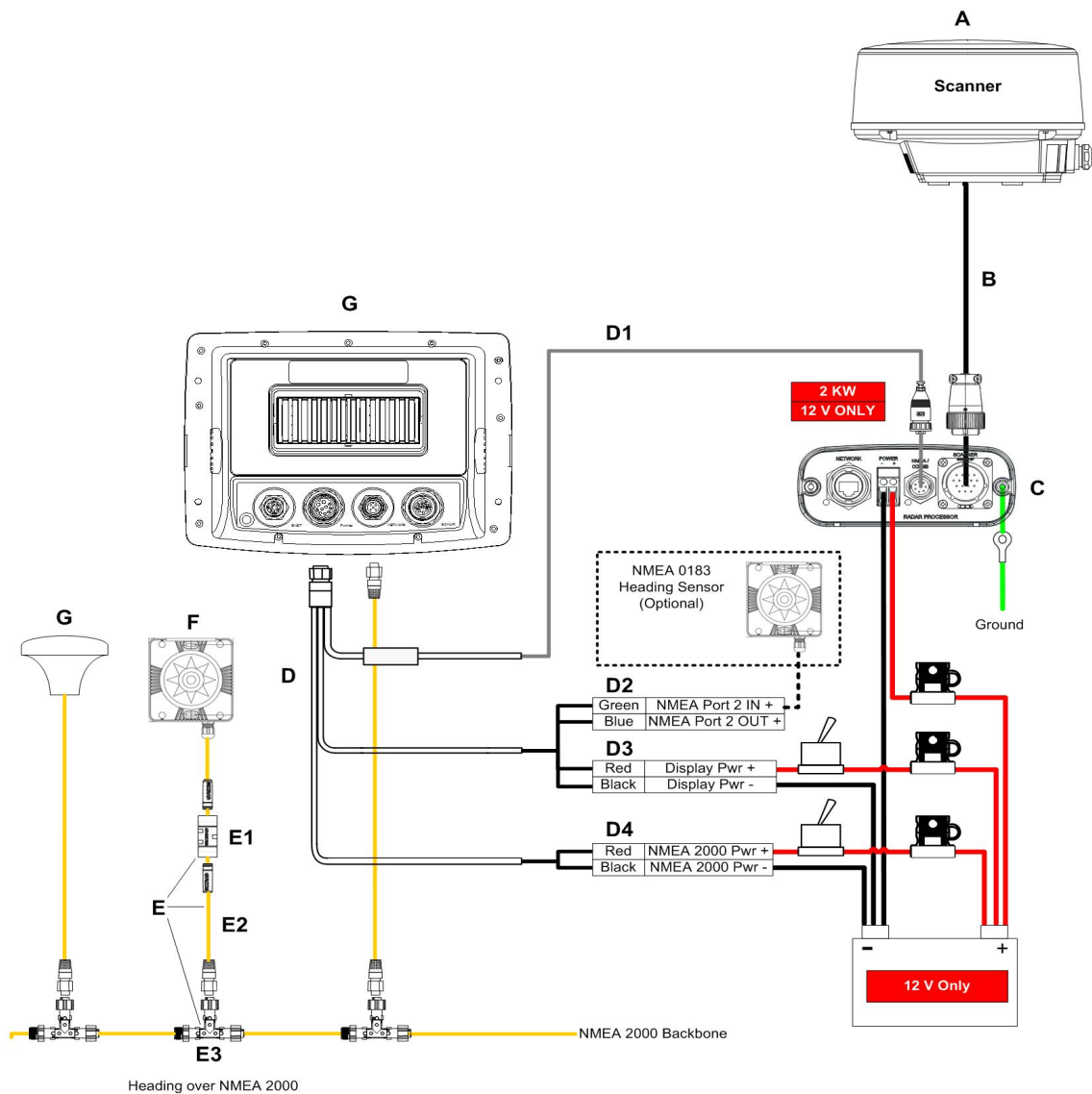

For information about radar processor wiring and connections, Wiring guidelines (see "Wiring the radar system" page 18).

A	2 kW AA010024 4 kW AA010025	2 kW scanner comes with a 15 m (49 ft) cable attached. (B) 4 kW scanner comes with a 15 m (49ft) cable that will need to be connected to the scanner. Cable from Scanner connects to Radar Processor box. An optional longer cable is available but only up to 20 m (65.5 ft). For scanner part numbers (see "Navico radar part numbers" page 75)
B	2 kW AA010089 4 kW AA010091	Optional 20 m (65.5 ft) scanner cable . Will require disassembly of scanner to connect. Cable has a radar processor connector on one end, and three small terminated flat connectors on the other. <b>CAUTION:</b> This cable should only be installed by an experienced radar service technician!
C	2 kW AA010012 4 kW AA010013	Radar processor box. No cables supplied. Connects to Lowrance displays via RS422 protocol, using optional RIM300 cable kit (D). Optional radar accessories kit (000-0127-45) The 2 kW system is 12 V DC ONLY 25 W max. Power connects to the two screw terminals. 4 kW system is 12 or 24 V DC
D	RIM 300 (003-7905-00) Radar Interface Module (RIM300) This cable will replace existing power cable. Consists of a Connector which branches to three separate cables, with four terminations. D1,D2,D3 and D4.Replacement part no. 000-0121-010.	

D1	Rim300 radar data	Connects to the Radar Processor module using the port labeled NMEA / COMMS.
D2	NMEA 0183 Port 2	For vessels using a NMEA 0183 heading sensor or other device. There is no ground wire so NMEA 0183 device must use the same ground as the display.
D3	Display Unit Power Cable	The RIM 300 uses 12 V DC only. Connect red to 12 V DC (+) via a switch (use the included 3-amp fuse). Connect the black wire to vessel ground.
D4	NMEA 2000 power	If powering a NMEA 2000 network or LGC-3000 GPS antenna. Connect red to 12 V DC (+) via a switch (use the included 3-amp fuse). Connect the black wire to vessel ground.  Note: Do not connect this if NMEA 2000 network is already powered.
E	000-0127-45 SimNet to NMEA 2000 Adapter kit, includes the following items	
E1	44172260	SimNet Cable Joiner. (44172260). Used to join the SimNet cable from the heading sensor to the SimNet to NMEA 2000 (Micro-C) cable.
E2	24005729	SimNet to Micro-C Cable (24005729). Converts SimNet to Lowrance NMEA 2000.
E3	037-0491-01	N2K-T-RD T connector (037-0491-01) Installed into the NMEA 2000 backbone.
F	FC40 or RC42	FC40 Fluxgate Compass (22090245) OR RC42 Rate Compass. (22090237).  Order separately. Sensor has a 5.5 m (18 ft) NMEA 2000 cable attached.
G	000-125-09	Lowrance LGC-3000 GPS antenna.
H		Lowrance displays that can use this radar are GlobalMap 9300c HD, GlobalMap 9200c, GlobalMap 8300c HD, GlobalMap 8200c, GlobalMap Baja 840c, GlobalMap 7300c HD, GlobalMap 7200c, Globalmap 5200c, Globalmap 5300c iGPS, Globalmap Baja 540c, LCX-113c HD, LCX-112c, LCX-38c HD, LCX-37c, LCX-28c HD, LCX-27c, LMS-520c, LMS-522c iGPS, LMS-522c iGPS Ice Machine, LMS-525c DF, LMS-527c DF iGPS, X510c, X515c DF

## 8.3 Set up the radar with Lowrance displays

### Introduction

The Radar Setup menu allows you to setup and adjust radar settings. Most of the settings in the Radar Setup menu will only have to be set once, but we recommend you check the settings periodically for general maintenance.

Before you begin radar setup, the radar scanning unit, RIM 300 module, radar processor and display unit all must be installed.



***DO NOT attempt to execute Radar Setup while the vessel is moving. Some motion from wind and wave action is acceptable, but these setup instructions are NOT intended for vessels moving across the water. Before starting radar setup, take your vessel out on open water with fairly calm seas, like an open bay.***

*Caution: If you are unsure or do not understand the following instructions, it is strongly recommended that an experienced radar technician handle radar setup and the installation of radar hardware.*

### Getting Started

- Press **Menu|Menu**, then use **↑ ↓** to **System Setup** and press **Ent**.
- Highlight **Communications Port** and press **Ent**.
- Press **↓** to **Radar LRA-1800 LRA-6000 LRA-2400** and press **Ent**. The Baud Rate automatically will switch to 230400 and a Radar Notice will appear.

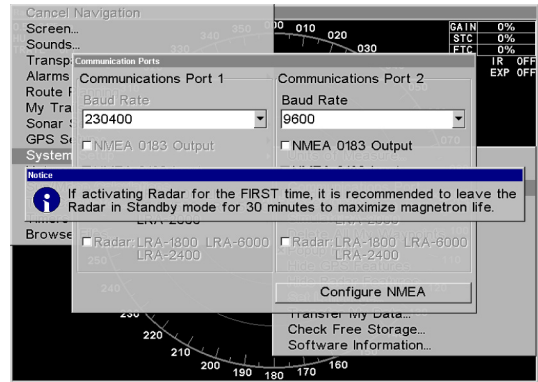
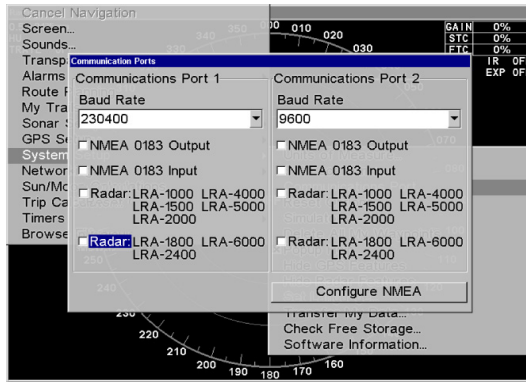

Communications Port menu (left). Radar Notice (right) prompting users to leave radar in Standby Mode for 30 minutes when activating radar for the first time.

*Caution: Leave the radar in Standby Mode for 30 minutes when activating it the first time. This will help maximize the life of the magnetron. After the radar has been activated the first time, ignore the Radar Notice.*

To access Radar Page:

- Press **Pages**, then use **← →** to select the radar tab.
- Press **↓** to select **Radar Only** then press **Exit**.

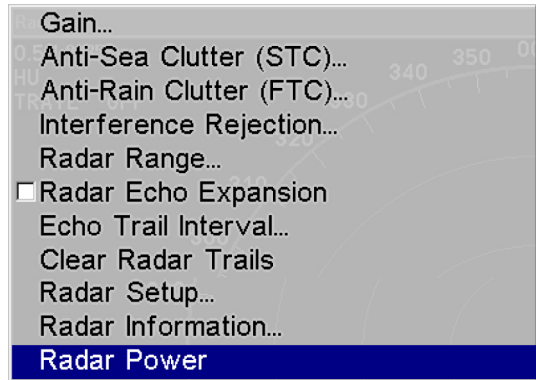
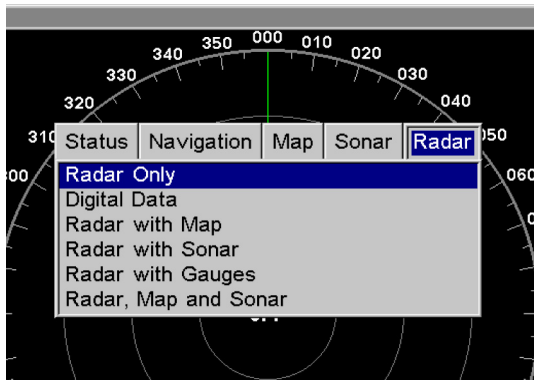

Radar only highlighted on Radar Pages menu (left). Radar menu with Radar Power selected (right).

- Press **Menu**, then use **↑↓** to select **Radar Power** from the radar menu and press **Ent**. A confirmation message will appear. Press **←** to select **Yes** and press **Ent**. A warm-up countdown will commence that will vary depending on the model of radar you have.
- After the countdown is finished, the unit will enter STANDBY mode.
- Access the Radar Setup menu to make sure your radar display is set to Heading Up and is set to a Full Color scheme. Press **Menu**, select **Radar Setup** and press **Ent**.

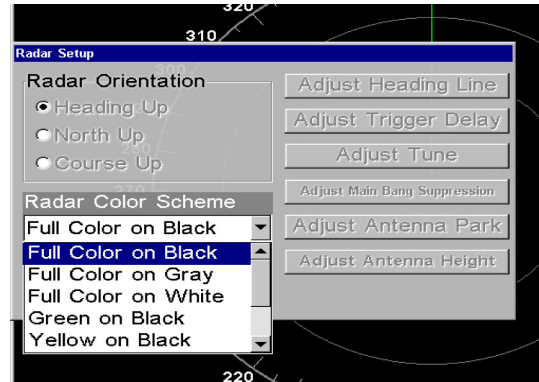
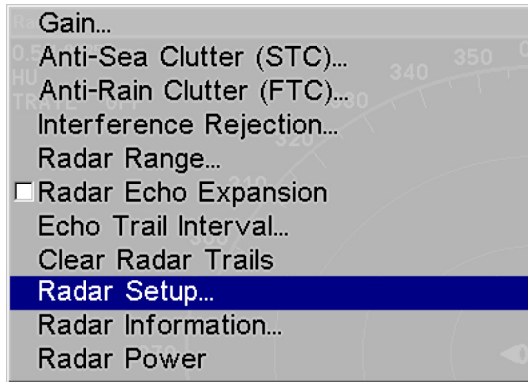

Radar Setup selected from Radar menu (left). Radar Setup menu with Full Color on Black highlighted (right).

- To set the radar to Heading Up, highlight **Heading Up** and press **Ent**.
- To display the radar images in full color, press **↓** to select **Radar Color Scheme** and press **Ent**.
- Use **↑ ↓** to highlight one of the three full color options and press **Ent**. Press **Exit** to return to the main page display.

### Radar Setup

The two setup features to be modified are Adjust Trigger Delay and Adjust Heading Line.

This will be set up in that order, but before making any adjustments, make sure the display is set to a range of 0.125 nautical miles and that Gain, Anti-Sea Clutter (STC), Anti-Rain Clutter (FTC) and Trigger Delay all have been set to zero percent.

### Trigger Delay Preparation

#### Range

- To reset range to 0.125 nm, make sure you are on the Radar Only page and press **Menu**.
- Use **↑ ↓** to select **Radar Range** and press **Ent**, which will call up the Radar Range list. Press **↑** to select 0.125 nm and press **Ent**. You also can set the range to 0.125 nm from the radar screen by using the **zin** and **zout** keys.

#### Gain

- To set Gain to zero, press **Menu**, select **Gain** and press **Ent**.
- Press **↓** until the Gain is set to zero percent. Press **Exit**. (Notice the corresponding value in the upper right-hand corner of the screen.)

*Note: When adjusting Gain back to a useable level, increase the level until you see a light peppering on the display. Also remember, you will have to adjust gain every time you change ranges.*

#### Anti-Sea Clutter

- To set Anti-Sea Clutter to zero, press **Menu**, select **Anti-Sea Clutter (STC)** and press **Ent**.
- Press **↓** until the Anti-Sea Clutter is set to zero percent. Press **Exit**. (Notice the corresponding value in the upper right-hand corner of the screen.)

#### Anti-Rain Clutter

- To set Anti-Rain Clutter to zero, press **Menu**, select **Anti-Rain Clutter (FTC)** and press **Ent**.
- Press **↓** until the Anti-Rain Clutter is set to zero percent. Press **Exit**. (Notice the corresponding value in the upper right-hand corner of the screen.)



## Trigger Delay

- To set Trigger Delay to zero, press **Menu**, *select Radar Setup* and press **Ent**.
- Press **→|↓** to *Adjust Trigger Delay* and press **Ent**. That will launch the Adjust Trigger Delay vertical scrollbar.
- Press **↓** until Trigger Delay is set to zero percent. Press **Exit**.

## Adjust Trigger Delay

This feature eliminates the time lag between real radar returns and the time it takes data to be processed by the radar software, a common issue with all radars.

*Caution: If you have any doubt about your understanding of the Trigger Delay feature, you should have it set up by a qualified radar technician.*

- The radar should already be in STANDBY mode, so press **PWR for 2 seconds** to switch the radar into transmission mode. A confirmation message will appear, press **←** to select **Yes**.
- Press **Menu**, select **Gain** and press **Ent**. Press **↑** to increase the Gain level to around 15%. One or two red rings with blue borders should be visible on the screen, depending on the wattage of your radar antenna.
- Press **→|↓** to *Adjust Trigger Delay*, then press **Ent**.
- The 2 kW model, the LRA-1800, will have only one ring on the display.
- The 4 kW model, the LRA-2400, will have two rings on the display. See the following figures.

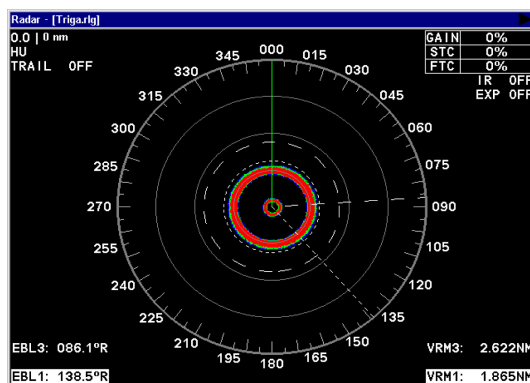

Before adjusting the Trigger Delay for 4 kW radars, two rings will be shown on the screen (left). As Trigger Delay is increased, the larger ring will start to get smaller. The smaller ring will disappear (right).

You may have to increase gain in the previous step if the rings are not visible. Increase gain until you have solid red rings shown on the screen, like in the preceding example. Increasing Gain too much can cause the rings to be distorted.

- Press **↑** to increase the level of Trigger Delay, which will decrease the size of the ring. If you have a 4 kW radar, as the large ring decreases in size, the smaller ring in the center of the screen will disappear, leaving only one ring.

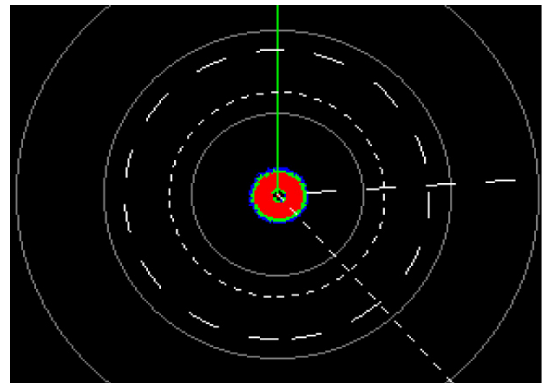
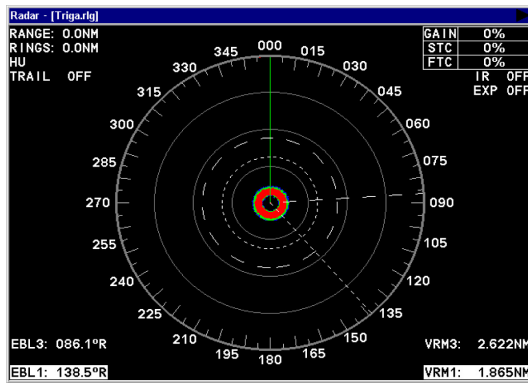

Increase Trigger Delay to diminish the size of the red ring (left). To set Trigger Delay correctly, reduce the ring to as small a size as possible, while keeping a black circle in the middle (enlarged view, right).

In either case, continue to increase the Trigger Delay level until the ring is as small as possible, while keeping a black circle in the middle. Every radar is different, but typically, a setting between 35 and 42 percent will get the job done.

If you over apply the Trigger Delay, the black circle will disappear. Decrease the Trigger Delay level and it will reappear.

- Press **Exit** to return to the main page display.

### Adjust Heading Line



*Note: After adjusting the trigger delay it is necessary to increase the gain back to normal levels and adjust the range as to display a clear picture of a point of reference such as a peninsula in order to adjust the heading line*

The Heading Line command is used to make sure the green heading line (zero point) on your display is lined up with the bow of your vessel.

(Before heading line adjustment)

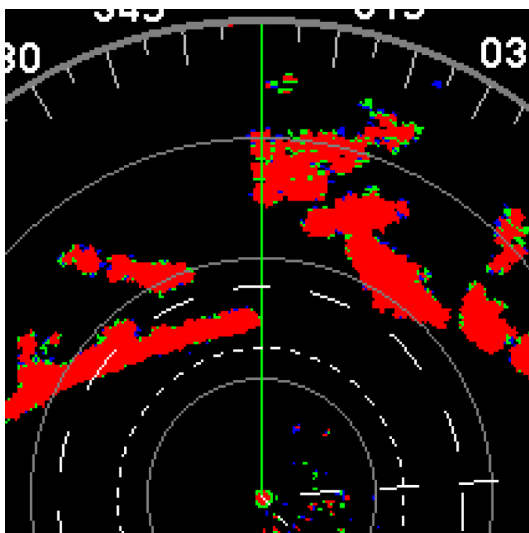

(After heading line adjustment)

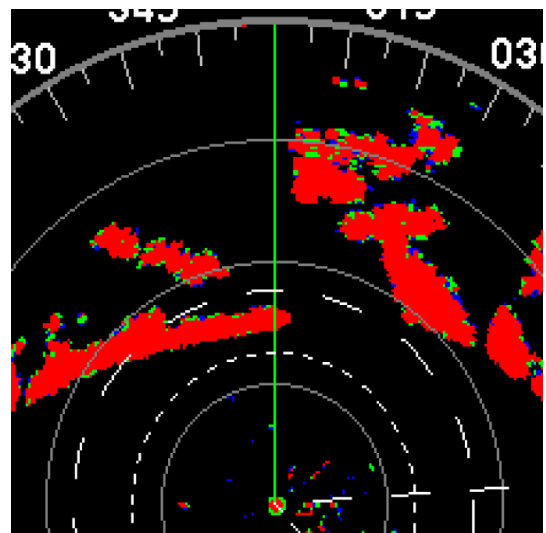

The bow of the ship is lined up with the tip of the peninsula (left), but the green heading line is not. Adjusting the heading line will allow you to align the direction of the heading line with the direction of the bow (right).

- Line up the bow of your vessel with a point of reference, like a peninsula, lighthouse or other stationary target.

- Press **Menu**, highlight **Radar Setup** and press **Ent**. Press **→** to select **Adjust Heading Line** and press **Ent**. That will place an arrow on each side of the green Heading Line.
- Use **← →** to adjust the position of the green heading line, so its line to the reference point's radar image matches your bow's actual line to the reference point.
- Press **Exit** to remove the heading line arrows from the display.

### **Adjust Tune**

Tuning should require no adjustment during the life of the unit. We strongly recommend you do NOT adjust Tune settings yourself. This feature is intended for use only by trained technicians. If for some reason you need to use this function, consult your dealer or customer service about the software updates necessary for tuning.

## 9 Maintenance



**Before doing any maintenance work, always ensure that the radar system is turned OFF at the main power source.**

***If a rectifier unit is used, turn OFF the power supply to this too. Remember that high voltages from the rectifier unit are always present, even if the radar is not operating, and these can cause severe injury or death.***

### 9.1 General maintenance

**Proper maintenance of the radar system will keep it in good condition and minimize breakdowns. Periodically:**

- remove any dust, dirt or sea salt from the external surfaces with a dry, lint-free cloth.
- check that the radar components are held securely in place and that the screws, nuts and bolts have not worked loose. Tighten and re-apply marine paint where necessary to prevent corrosion.
- check that all the radar cabling is not frayed, bent, or cut and that the radar system cable connections are secure, tight and waterproof.

### 9.2 Scanner maintenance



*Note: Before working on the scanner, remove your watch and any magnetic cards, because the modulator circuit in the magnetron emits a strong magnetic field that can badly affect such items*

- Remove any dust, dirt, or sea salt from the external surfaces, particularly the front side of the scanner, with a lint-free cloth dampened with water. Do NOT use petrol, gasoline, benzene, thinner, or similar solvent to dampen the cloth as these cause deterioration of the external surfaces.
- At least once every six months, apply grease (Mobilux 2 or equivalent) evenly to the lubricating gears, with a brush or knife. More frequent application is desirable to maximize the life of the lubricating gears.
- Open scanners only: The drive motor brush has an expected life of 2,000 hours. Replace it when half of the overall length has worn away. The drive motor carbon brush can be removed easily by unclipping the two caps located on both sides of the bottom part of the drive motor.
- Open scanners only: Clean any carbon powder off the drive motor commutator with a dry brush or, if this will not remove it, use sand paper #250 to #400.

### 9.3 Other maintenance items

Re-set the heading calibration annually and after any major structural changes to the vessel.

## 10 Troubleshoot the radar

This appendix gives information on fixing possible problems with the radar. Many problems are caused by:

- faulty or loose contacts at switches and relay points
- poor adjustment of the radar (particularly inadequate tuning adjustment)
- poor maintenance (particularly of the cables)

You'll save yourself a considerable amount of time if you check these items before placing a call to Navico; plus, you may find the problem right away.

### 10.1 Technical support, service and repairs

The product is covered by a warranty which is supplied as a separate document.

If you need technical support or answers to other questions after you've followed the instructions in this manual, you can:

- contact your Navico distributor or
- see the inside back cover of the manual or
- visit [www.navico.com](http://www.navico.com)

Before you make contact, be sure to have:

- the serial number of the hardware (usually shown on the faceplate of the unit).

When you describe the problem, be as complete and as accurate as possible.

### 10.2 Radar is not operating correctly

If no image appears on the screen and screen shows message no scanner detected:

- check radar scanner interconnect cable wiring.

If no image appears on the screen and the screen shows message no radar detected:

- check the data cable between the radar and the display head system
- check that the radar processor has power

If the scanner is working but no image appears on the display:

- adjust gain and threshold

If the display shows only noise:

- check that the scanner and open array (if applicable) are fitted correctly

If radar reception is poor:

- check for physical damage to the cables (such as fraying) and for any loose connections
- check for water damage to the radiator or to the cables between the radar components
- check for interruptions in the pulse switching signal

If an image appears on the display but the direction of the radar image is not stable:

- the direction standard signal (BZ) is being interrupted (see the Service Manual)
- check for water damage to the radiator or cables between the radar components.

### 10.3 If the scanner fails to turn

If the scanner fails to turn, it is possible that there has been a breakdown of either the motor unit inside the scanner or the safety switch of the scanner unit.

Turn the power OFF and investigate as follows:

- Visually check for, and remove, any external obstruction.
- Open the scanner dome or gearbox and perform an internal inspection.

- Check to make sure that nothing is interfering with the motor and gears, is binding or preventing the antenna from turning.
- Check for any disconnected, pinched or broken wires.
- Check for worn or broken motor brushes (open scanners only).
- Verify that the scanner cable is correctly pinned, all wires are in the correct locations and the connectors are correctly locked to the mating connectors on the modulator board.
- Check the motor and replace any faulty component. (See the Service Manual for information on replacing the motor)
- Check the wiring of the interconnection cable between the scanner and the radar processor.
- Checking these connections is especially important if the installer removed the connectors for easy routing when installing the scanner cable.

#### **10.4 How to reduce noise and interference**

If other electronic equipment on the vessel is being affected by noise interference from the radar, check that the radar is actually the source of the problem by switching it off, running the other electronic equipment for a while to see if the noise interference has disappeared, and then switching the radar on again.

If the radar is causing the noise interference, check that:

- the affected piece of equipment and/or the antenna is not located within the radar beam. (For information about the optimum installation height and the radar beam width (see "Install the radar" page 9),).
- the cables supplied with the equipment have been installed correctly. In particular, check for loose connections and loose or missing shield meshwork at the cable ends.
- the covers of the scanner and radar processor box are securely screwed and/or fastened in place, so that the internal shielding is effective.
- each piece of radio equipment is grounded to the closest ground location, and that other devices are grounded to the closest ground location on the hull.
- the radar cabling has not been bundled with the VHF radio cabling and/or with the direction finder cabling. The radar cabling must always be separate.

#### **10.5 Make sure the power is present and correctly wired**

Check the in-line fuse.

Re-verify that the correct system voltage is being used for the radar processor box model and that the power is properly wired. If the radar processor has incorrect power, the system may not initialize properly or the radar processor may be damaged.

# 11 Drawings

## 11.1 Radar scanner: 2 kW dimensions

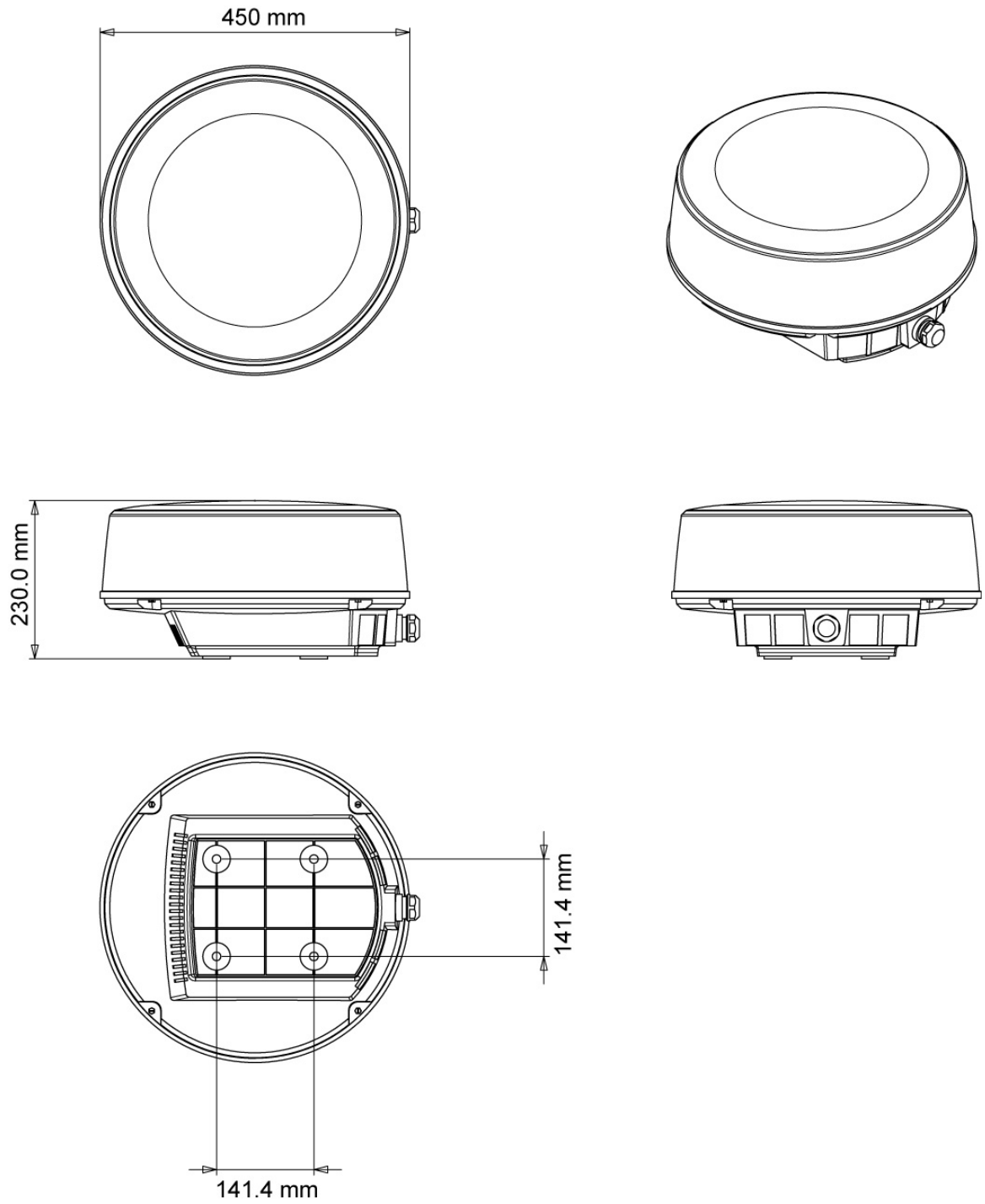

## 11.2 Radar scanner 4 kW: Dimensions

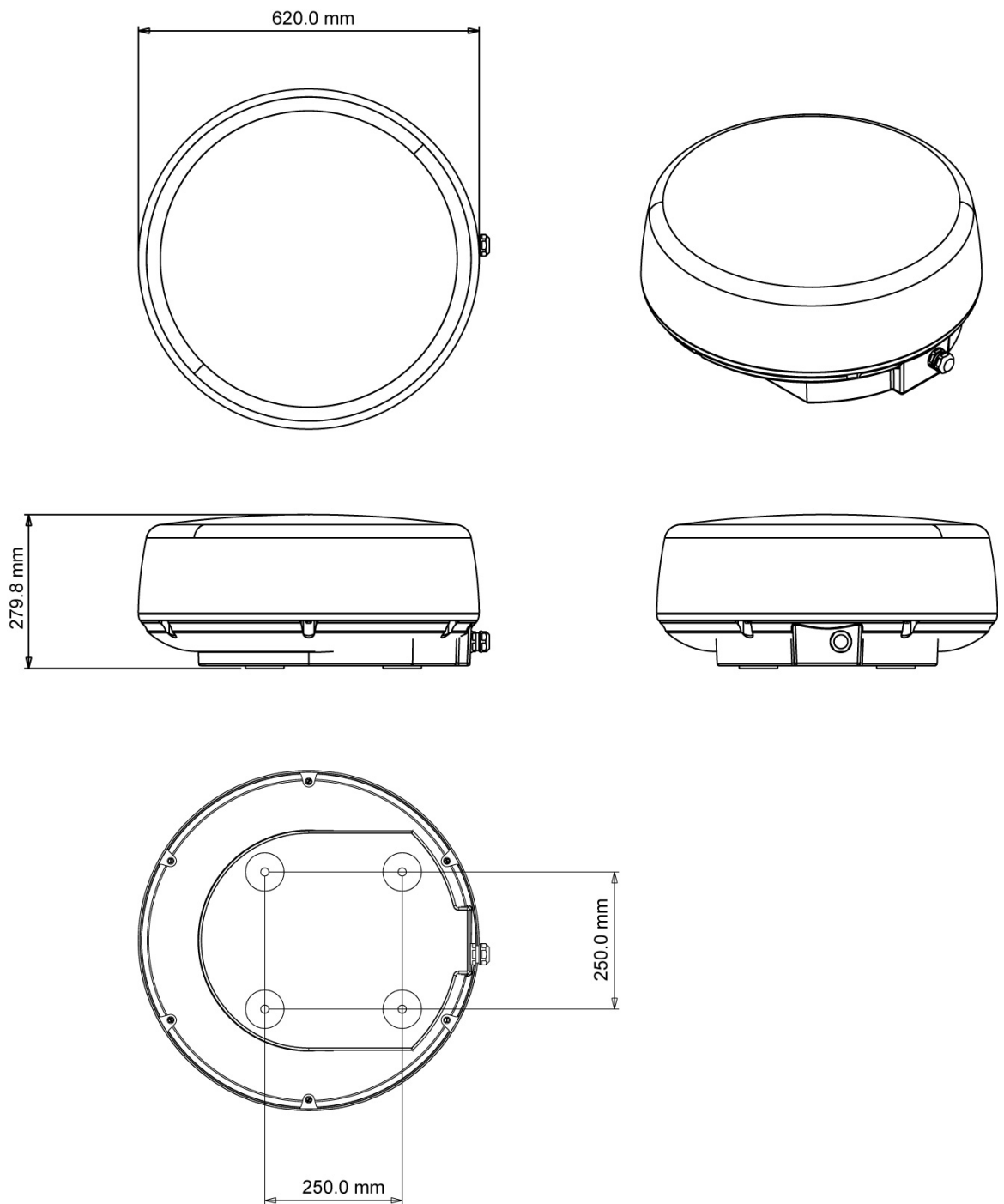



### 11.3 Radar processor: Dimensions

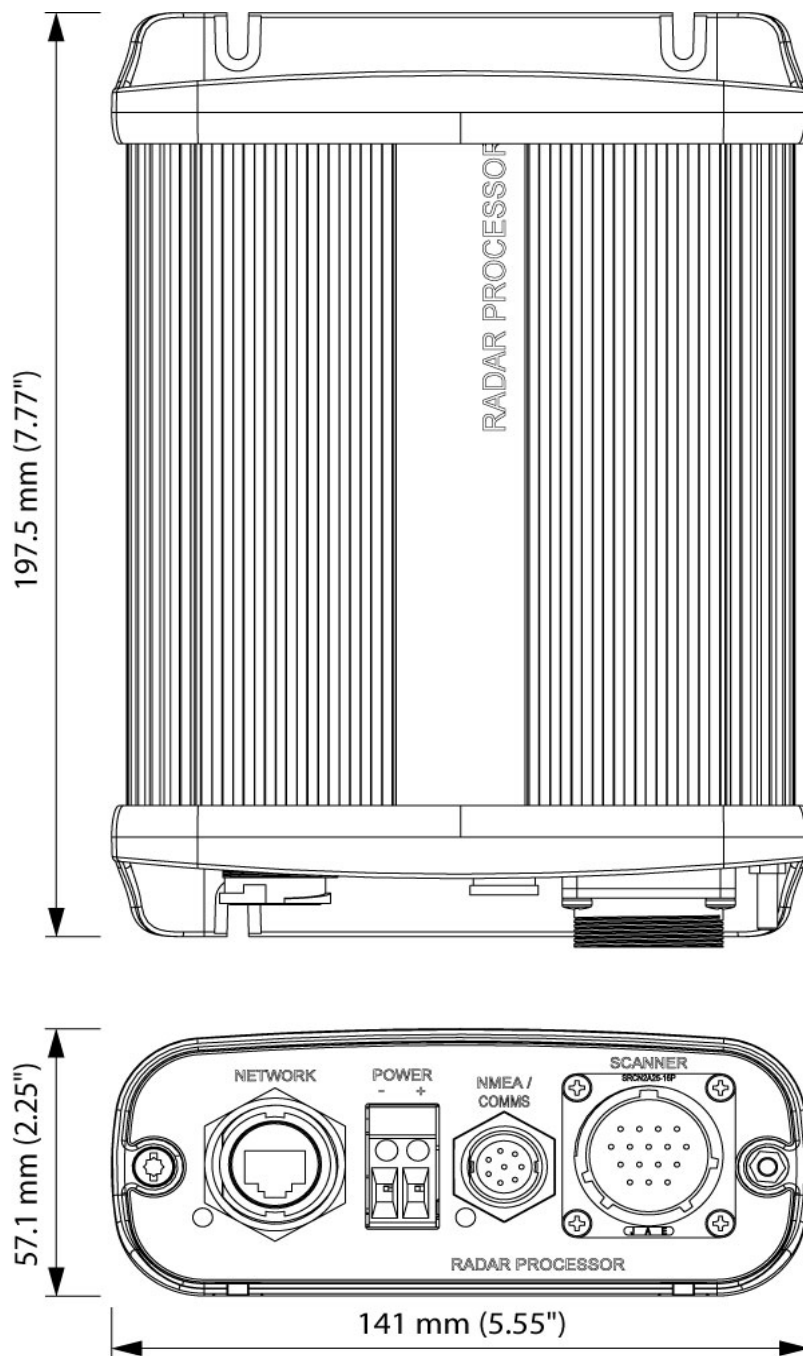

## 12 Specifications

### 12.1 2 kW radar system specifications

	<b>2 kW scanner</b>
<b>DC input</b>	<b>10.8 V to 15.6 V DC (DC 12 V system ONLY)</b>
Scanner type	Radome
Scanner model	AA010024
Scanner dimensions	Depth: 17.7" (450 mm) Height: 8.93 (227 mm)
Scanner weight	9.26 lbs (4.2 kg) ± 5%
Vibration Amplitude	0.1" (3 mm) (0 to 500 cpm) 0.29" (0.75 mm) (550 to 1500 cpm) 0.007" (0.2 mm) (1500 to 3000 cpm)
Waterproof	IPX6
Plane of polarization	Horizontal
Preheating time	Minimum 90 seconds
Power consumption	25 W (maximum) at 12 V DC
Emission type	P0N FCC ID: CKEJMA1020 IC ID: 768381105A R&TTE: DERA-RTTE-34/01-01
Peak power output	2 kW ± 50% under any pulse conditions
Transmitter frequency	9445 ± 30 MHz
Transmitter tube	Magnetron NJRC M1537
Horizontal beam width	5.2° ± 10% (3 dB width)
Vertical beam width	30° ± 20% (3 dB width)
Side lobe level	< -21 dB maximum (within ± 10°)
Rotation rate	27 rpm ±10%
Pulse length/PRF	0.08 μs +50/-25% (2250 Hz) 0.3 μs +50/-30% (1200 Hz) 0.8 μs ±25% (600 Hz) See Pulse Width and Bandwidth Selector table (below).
Duplexer	Microwave T-junction with diode limiter Model NJRC NJS6947
Mixer	MIC front-end
IF amplifier	Center frequency 60 MHz ± 3 MHz
IF amplifier output	14 dB for -3.2 V into 50 ohms (typical)
IF band width	10 MHz ±3 MHz (0.08 μs) 3 MHz ±1 MHz (0.3 μs, 0.8 μs)
IF characteristic	Linear
Gain	Minimum 90 dB
Noise figure	NJT1027 @ 7 dB (average) at front-end input
Temperature range	+5°F to +131°F (-15°C to +55°C)
Relative humidity	95% at 95°F (35°C)
Relative wind velocity	118.11 ft (36.0 m)/sec (maximum 70 knots)

	<b>2 kW Radar processor specifications</b>
Processor model	AA010012
Processor dimensions	Width 5.6" (142 mm) Height 2.2" (56 mm) Length 7.9" (200 mm)
Processor weight	1.9 lbs (870 g)
Vibration	EN60945
Waterproof	No rating
Temperature range	+5°F to +131°F (-15°C to +55°C)
Relative humidity	95% at 104°F (+40°C)
Power up time	Approximately 35 seconds
DC input	10.8 V to 15 V DC
Power consumption	3 W (when operating) Leakage current <200 µA (when off, with a remote power input)

## 12.2 4 kW Specifications

	<b>4 kW Scanner specifications</b>
Radar system	
Northstar	NS-RDR1042MD
Simrad	DX64s
Lowrance	LRA-2400
Scanner dimensions	Width 24.5" (620 mm) Height 11" (280 mm)
Scanner type	Dome
Scanner model	AA010025
Scanner weight	22 lbs (10 kg ± 5%)
Vibration	Amplitude 0.12" (3 mm) at 0 cpm to 500 cpm Amplitude 0.03" (0.75 mm) at 500 cpm to 1500 cpm Amplitude 0.01" (0.2 mm) at 1500 cpm to 3000 cpm
Waterproof	IPX6
Scanning mode	Raster scanning, PPI
Plane of polarization	Horizontal
Preheating time	Minimum 90 seconds
Warm-up time	Approximately 3 seconds
Power consumption	30 W (maximum) at 24 V DC
DC input	10.8 V to 42 V (DC 12/24/32 V system)
Emission type	P0N. Passed JRC FCC/IC/R&TTE Type Certification: FCC ID: CKENKE249 IC ID: 768C-NKE249 R&TTE: QQ-RTTE-02/03-01
Peak power output	4 kW ± 50% under any pulse condition
Transmitter frequency	9410 ± 30 MHz
Transmitter tube	Magnetron NJRC Model MSF1421B
Horizontal beam width	4° ± 10% (-3 dB width)
Vertical beam width	25° ± 20% (-3 dB width)
Side lobe level	Below -21 dB maximum (within ± 10°)
Rotation rate	27 rpm ± 10%

Pulse length/PRF	0.08 $\mu\text{s} \pm 30\%$ 2250 Hz $\pm 5\%$ 0.2 5 $\mu\text{s} \pm 25\%$ 1700 Hz $\pm 5\%$ 0.5 $\mu\text{s} \pm 25\%$ 1200 Hz $\pm 5\%$ 1.0 $\mu\text{s} \pm 25\%$ 65 0Hz $\pm 5\%$
Duplexer	Circulator and diode limiter Model NJRC NJS6930
Mixer	MIC front-end
IF amplifier	Center frequency 60 MHz $\pm 3$ MHz
IF bandwidth	20 MHz $\pm 3$ MHz (0.08 $\mu\text{s}$ ) 6 MHz $\pm 2$ MHz (0.25 $\mu\text{s}$ ) 3 MHz $\pm 1$ MHz (0.5 $\mu\text{s}$ , 1.0 $\mu\text{s}$ )
IF characteristic	Log
IF output	-2 V for 100 dB typical Bandwidth controlled by serial port
Com port	RS485 9600 bps Half Duplex Defined in NS-RDR1042MD Digital COM specification
Gain	Minimum 90 dB
Noise figure	NJT1028 @ 6 dB (average) at front-end input
Temperature range	+5°F to +131°F (-15°C to +55°C)
Relative humidity	93% at 104°F (+40°C)
Relative wind velocity	118 feet (36 m)/sec (maximum 70 knots)

<b>4 kW Radar processor specifications</b>	
Processor model	AA010013
Processor dimensions	Width 5.6" (142 mm) Height 2.2" (56 mm) Length 7.9" (200 mm)
Processor weight	1.9 lbs (870 g)
Vibration	EN60945
Waterproof	No rating
Temperature range	+5°F to +131°F (-15°C to +55°C)
Relative humidity	95% at 104°F (+40°C)
Power up time	Approximately 35 seconds
DC input	10.8 to 36 V (DC 12/24/32V system)
Power consumption	3 W (when operating) Leakage current <200 $\mu\text{A}$ (when off, with a remote power input)

## 13 Navico radar part numbers

Radar Kits			
SIMRAD			
	Description	Old part numbers	2009 Part numbers
	DX42S 18" radome 2 kW w/ 15 m cable and radar processor	Dx42S-1	Dx42S-1
	DX64S 24" radome 4 kW w/ 15 m cable and radar processor	Dx64S-1	Dx64S-1
	TX06S 6kw / 4ft open array w/20 m cable and radar processor	Tx06S-1	Tx06S-1
	TX10S 10kw / 6ft open array w/20 m cable and radar Processor	Tx10S-1	Tx10S-1
	TX25S 25kw / 7ft open array w/20 m cable and radar Processor	TX25S-1	TX25S-1
NORTHSTAR★			
	18" radome 2 kW w/ 15 m cable and radar processor	NS007001	NS007001
	24" radome 4 kW w/ 15 m cable and radar processor	NS007002	NS007002
	6 kW / 4ft open array w/20 m cable and radar processor	NS007003	NS007003
	10 kW / 6ft open array w/20 m cable and radar Processor (Not for M-series)	NS007004	NS007004
	25 kW / 7ft open array w/20 m cable and radar Processor (Not for M-series)	NS007005	NS007005
LOWRANCE			
	18" radome 2 kW w/ 15 m cable, radar processor and connection kit	000-0121-08	000-0121-08
	24" radome 4 kW w/ 15 m cable, radar processor and connection kit	000-0121-09	000-0121-09

Scanners			
SIMRAD			
	Description	Old part numbers	2009 Part numbers
	DX42S 18" radome 2 kW w/ 15 m cable		AA010024SIM
	DX64S 24" radome 4 kW w/ 15 m cable		AA010025SIM
	TX06S 6 kW / 4ft open array w/20 m cable		AA010026SIM
	TX10S 10 kW / 6ft open array w/20 m cable		AA010027SIM
	TX25S 25 kW / 7ft open array w/20 m cable		AA010028SIM
NORTHSTAR★			
	18" radome 2 kW w/ 15 m cable	NS004790	AA010024NOR
	24" radome 4 kW w/ 15 m cable	NS004791	AA010025NOR
	6 kW / 4ft open array w/20 m cable	NS004792	AA010026NOR
	10 kW / 6ft open array w/20 m cable	NS004793	AA010027NOR
	25 kW / 7ft open array w/20 m cable	NS004794	AA010028NOR
LOWRANCE			
	18" radome 2kW w/ 15 m cable		AA010024LOW

	24" radome 4kW w/ 15 m cable		AA010025LOW
<b>Radar processors</b>			
	2 kW Navico radar processor module	NS004780R	AA010012
	4 kW Navico radar processor module	NS004781R	AA010013
	6 kW Navico radar processor module	NS004782R	AA010014
	10 kW Navico radar processor module	NS004783R	AA010015
	25 kW Navico radar processor module	NS004784R	AA010016

<b>Scanner cables</b>			
	<b>Description</b>	<b>Old part numbers</b>	<b>2009 Part numbers</b>
	20m cable for 2 kW dome (optional)	NS003101	AA010089
	20m cable for 4 kW dome (optional)	NS003103	AA010091
	20m cable for 6 kW open array	NS003104	AA010092
	20m cable for 10/25 kW (required 20 m or 30 m)	NS003105	AA010093
	30m cable for 10/25 kW (required 20 m or 30 m)	NS003106	AA010094
<b>Ethernet cables</b>			
	8 port Ethernet linker	NS004721	AA010009
	0.5 meter (16") ethernet cable	NS004810	AA010079
	2 meter (6.6") ethernet cable	NS004811	AA010080
	5 meter (16.5") ethernet cable	NS004812	AA010081
	10 meter (33") ethernet cable	NS004813	AA010082
	Ethernet male to male joiner	NS004814	AA010083
	Ethernet cross-over male to male joiner	NS004815	AA010084
	Ethernet field termination kit	NS004816	AA010085
<b>Cables other</b>			
	2 m Cable for connection of NMEA0183 (GB40 / 8000i)	NS004801	AA010070
	Lowrance RIM300 radar interface cable		003-7989-00
	Lowrance NMEA 2000 to Simnet adapter kit		000-0127-45
	6100i Radar/Smartcraft Interface Cable	NS003107	NS003107
	Radar connection kit (incl Y-cable/NMEA for pilot/heading sensor) Simrad NX, Northstar M-Series	AA002461	AA010112
	Simrad NX, 3 m serial communication cable	AA002463	AA010114



