



www.alltekmarine.com

↓
→ [AIS Receiver] ←

↑
CYPHO-150

SWB
USER MANUAL



i. Copyright

The entire contents of this instruction manual, including any future updates, revisions, and modifications, shall remain the property of AMEC at all times. Unauthorized copies or reproduction of this manual, either in part or whole, in any form of print and electronic media, is prohibited. The contents herein can only be used for the intended purpose of this manual.

ii. Disclaimer

AMEC is devoted to publish and maintain this product manual. As we continue to improve our AIS products to satisfy all customers' needs, information in this document is subject to change without notice. AMEC does not make any representations or warranties (implied or otherwise) regarding the accuracy and completeness of this document and shall in no event be liable for any loss of profit or any commercial damage, including but not limited to special, incidental, consequential, or other damage.

SVMB

iii. Safety Warning



It is important to know that AIS is designed for the purpose of anti-collision and serves as a complement to navigation. It is not the absolute navigational equipment and does not replace any navigational system installed on board. Any AIS device cannot guarantee monitoring and receiving signals from all vessels in the surroundings unless those vessels are equipped with AIS devices.



ELECTRICAL SHOCK HAZARD

Improper disassembly or modification could cause electrical shocks, fire, or personal injury. Only qualified personnel could work on the interior of the equipment.



CORRECT POWER SOURCE

An incorrect power sources will damage the equipment and may even result in fire. Ensure the correct power input on the adaptor before installation.



AVOID DIRECT CONTACT WITH RAIN OR SPLASHING WATER

Electrical shock or fire could be resulted if water leaks into the equipment.



AVOID USING CHEMICAL SOLVENTS TO CLEAN THE CASE

As some solvents can damage the case material.



NOTE/INFORMATION

Important notices and information will be noted in this Installation and Operation Manual

iv. Product Category

This product is categorized as “protected” in accordance with the requirements as defined in IEC 60945.

v. Disposal Instruction

Do not dispose of this device with unsorted waste.

Improper disposal may be harmful to the environment and human

health. Please refer to your local waste authority for information on return and collection systems in your area.

vi. Contact Information

For sales, services, and technical supports, please contact your local AMEC representatives or Alltek Marine Electronics Corp at sales@alltekmarine.com or service@alltekmarine.com



Table of Content

| | | |
|----------|---------------------------------------|-----------|
| 1 | INTRODUCTION | 1 |
| 1.1 | CYPHO-150 Overview | 1 |
| 1.2 | Comparison of CYPHO-150 Series | 3 |
| 1.3 | Type of AIS | 4 |
| 1.4 | AIS Message Type..... | 5 |
| 1.5 | About This Manual | 7 |
| 1.6 | Important Notice..... | 8 |
| 2 | GETTING STARTED | 9 |
| 2.1 | Items in the Package | 9 |
| 2.2 | Power ON / OFF | 11 |
| 2.3 | CYPHO-150 LED Indicators | 12 |
| 2.4 | CYPHO-150S LED Indicators | 14 |
| 3 | INSTALLATION | 16 |
| 3.1 | CYPHO-150 Connection Interface | 16 |
| 3.2 | CYPHO-150S Connection Interface | 17 |
| 3.3 | Installation Precautions..... | 18 |
| 3.4 | Mounting Instructions | 18 |
| 3.5 | Wiring Instructions | 21 |
| 3.6 | VHF Antenna Installation | 26 |
| 3.7 | Antenna Cabling..... | 28 |
| 3.8 | USB Driver Installation | 29 |
| 3.9 | CYPHO Configuration Software | 31 |
| 3.9.1 | Software Installation | 31 |
| 3.9.2 | Configuration | 35 |

| | | |
|----------|---|-----------|
| 3.9.3 | Diagnosis..... | 37 |
| 3.10 | NMEA 0183 Multiplexer..... | 41 |
| 3.11 | AMEC AIS Viewer Software Installation | 43 |
| 4 | APPENDIX | 44 |
| 4.1 | Product Specifications..... | 44 |
| 4.2 | Dimensions | 47 |
| 4.3 | Accessories (Optional)..... | 48 |
| 5 | FCC INTERFERENCE STATEMENT | 52 |
| 6 | DECLARATION OF CONFORMITY | 53 |
| 7 | ACRONYMS | 54 |



1 INTRODUCTION

1.1 CYPHO-150 Overview

The AMEC CYPHO-150 (any CYPHO-150 model) is an AIS receiver series. It receives AIS navigation data from AIS-equipped vessels nearby and improves navigation safety. CYPHO-150 series is designed to inter-operate with AIS Class A or Class B transponders, and any other AIS station operating on the AIS VHF data link.

CYPHO-150 series is built with two parallel AIS receivers in one box monitoring the default marine VHF-AIS channels, i.e. 161.975 and 162.025 MHz with optimized sensitivity. Having CYPHO-150 series AIS receiver on board, not only can you monitor the status of the vessels in the surrounding area, but also receive the dynamic information (position, speed, SOG, etc.), static information (ship name, MMSI, call sign, etc.), and voyage related information (cargo type, destination, etc.) from any vessels nearby that are equipped with AIS transponders.

Equipped with standard USB and NMEA0183, CYPHO-150 series allows connectivity to most available peripherals in the market. Users are able to view AIS information on their preferred PC based navigation systems via the USB interface.

CYPHO-150 series is IPX2 water resistant providing acceptable protection against water. But it does require a protected installation environment away from water.



Figure 1 **CYPHO-150**

1.2 Comparison of CYPHO-150 Series

| Description | CYPHO-150 | CYPHO-150S |
|------------------------|-------------------------------------|-------------------------------------|
| Number of AIS Channels | 2 | 2 |
| USB port | 1 | 1 |
| NMEA 0183 | Independent 1 input, 1 output | Independent 1 input, 1 output |
| Built-in AIS splitter | | Yes |

1.3 Type of AIS

The different types of AIS devices are described below. The CYPHO-150 is the name of an AIS receiver series.

| | |
|--------------------------------|--|
| Class A AIS Transponder | <ul style="list-style-type: none">• Transmits and receives AIS signal.• Intended for vessels meeting the requirements of IMO AIS carriage requirement.• It is mandatory for all commercial vessels that exceed 300 tons to be equipped with Class A AIS. |
| Class B AIS Transponder | <ul style="list-style-type: none">• Transmits and receives AIS signal.• Not necessarily in full accord with IMO AIS carriage requirements.• It is not mandatory for vessels to be equipped with Class B AIS.• Suitable for recreational vessel, in enhancing its safety at sea. |
| AIS Receiver | <ul style="list-style-type: none">• Only receives AIS signal.• Does not have transmitter to send out AIS signal.• Suitable for recreational vessel that does not want to send out its vessel information. |

1.4 AIS Message Type

The CYPHO-150 models can receive AIS messages from both Class A and Class B AIS transponders as well as from AIS Base Station, AIS AtoN, and AIS SART/MOB. The message types are listed as below table. The messages in gray color are transmitted only from class A AIS device.

| Type of Message | Data Details |
|--------------------|--|
| Static Data | Maritime Mobile Service Identity (hereinafter called "MMSI") number IMO number Call sign and name Type of ship Length and beam GPS Antenna location |

| | |
|----------------------------|---|
| Voyage Related Data | Draught of the ship Cargo information Destination Estimate Time of Arrival (hereinafter called "ETA") |
| Dynamic Data | Position of the vessel Coordinated Universal Time (hereinafter called "Time in UTC".) Course Over Ground (hereinafter called "COG") Speed Over Ground (hereinafter called "SOG") Heading Rate of turn Navigational status |
| Dynamic Reports | Speed of the ship Status of the ship |
| SRM | Alarm Safety |

1.5 About This Manual

The manual contains installation instructions and operating information for both CYPHO-150 and CYPHO-150S. While most of the installation can be performed by the owner or the crew, a final commissioning can be done by your local agent/dealer when needed or required. AMEC and the local agent/dealer will not bear any responsibilities over any damages resulted in improper installation by unauthorized agent/dealer.

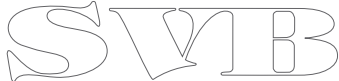
The logo consists of the letters 'S', 'V', 'I', and 'B' in a stylized, outlined font. The 'S' is on the left, followed by 'V', 'I', and 'B' to its right. The letters are interconnected and have a decorative, slightly calligraphic appearance.

1.6 Important Notice



The intended use of the AMEC CYPHO-150 Series Automatic Identification System Receiver is to enhance the safety of vessels at sea. However, a few points must be addressed:





- Under certain regulations, some specified vessels are compulsory to be installed with AIS. However, this does NOT mean that all vessels will be equipped with AIS. Any AIS will NOT guarantee to monitor and to receive signals from every ship in the surroundings.
- AIS acts as aids to navigation in the purpose of decreasing or preventing the possibility of vessel collision. It is not the absolute navigational equipment and does not replace any navigational system installed on board.
- This product is a marine AIS receiver intended for worldwide use on NON SOLAS vessels.

2 GETTING STARTED

2.1 Items in the Package

Please contact your supplier immediately if there is any item missing.

| No. | Diagram | Description | Qty |
|-----|---|----------------------------------|-----|
| 1 |  150 | CYPHO-150 AIS Receiver series | 1 |
| |  150S | | |

| | | | |
|---|--|--|---|
| 2 |  | Power/USB/ NMEA0183 Cable, 1m (Wired to the unit) | 1 |
| 3 |  | User's Manual | 1 |
| 4 |  | CD-ROM (User's manual in digital format, Configuration Utility, USB driver) | 1 |
| 5 |  | Mounting screws 4 M3.5x25 | 4 |
| 6 |  150S only | VHF cable, 1m (with PL-259 male connectors) | 1 |

2.2 Power ON / OFF

All CYPHO-150 models are designed having no physical On/Off switch. Thus, the vessel's operation determines the unit's power status.



Note the unit should be wired using suitable fusing to ensure safe operation and to protect it from damage. A 2 amp fuse or circuit breaker is recommended for this.



If PC could not recognize USB connection after a power restart on CYPHO-150, please re-plug the USB connector.

2.3 CYPHO-150 LED Indicators

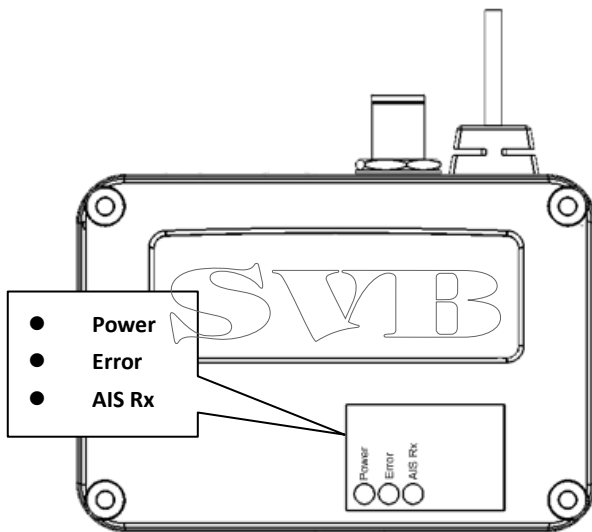

Figure 2 CYPHO-150 LED Indicators

LED INDICATIONS

| Indicator | Indication | Description |
|---------------|---------------------|---|
| Power | Normal Steady Green | Device in normal operation |
| Error | Flashing Red | Error is detected by the onboard system |
| AIS Rx | Flashing Green | Receiving of AIS message in either AIS Channel 1 or Channel 2 |

2.4 CYPHO-150S LED Indicators

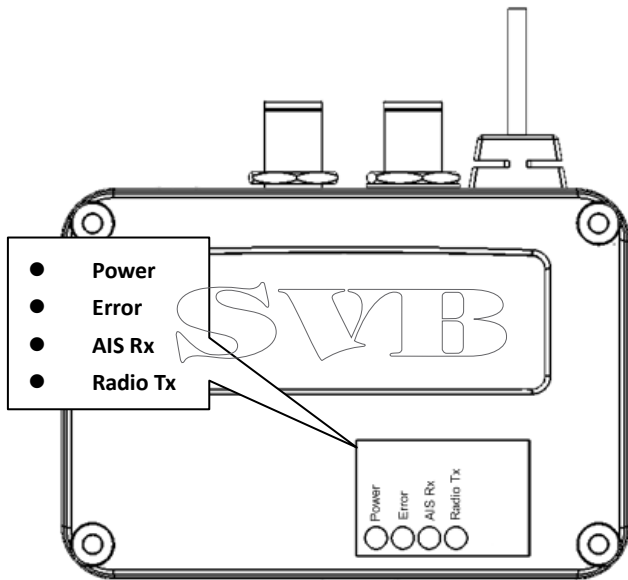

Figure 3 CYPHO-150S LED Indicators

LED INDICATIONS

| Indicator | Indication | Description |
|-----------|---------------------|---|
| Power | Normal Steady Green | Device in normal operation |
| Error | Flashing Red | Error is detected by the on-board system |
| AIS Rx | Flashing Green | Receiving of AIS message in either AIS Channel 1 or Channel 2 |
| Radio Tx | Flashing Green | VHF radio is transmitting |

3 INSTALLATION

3.1 CYPHO-150 Connection Interface

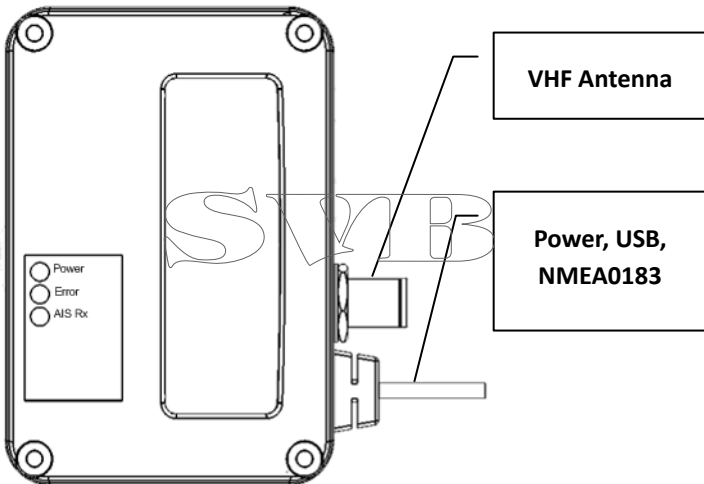

Figure 4 CYPHO-150 Connection Interface

3.2 CYPHO-150S Connection Interface

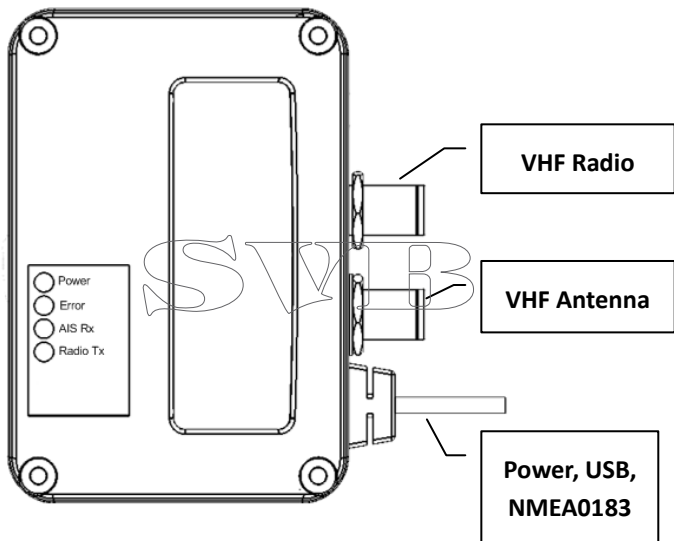

Figure 5 CYPHO-150S Connection Interface

3.3 Installation Precautions

CYPHO-150 models require a protected installation environment away from water. Find a proper location prior to the installation process. If drilling holes are necessary, always wear eye goggle for protection.

3.4 Mounting Instructions

AMEC CYPHO-150 models can be installed and mounted on either flat surface or wall.



The mounting instructions apply to all CYPHO-150 models.

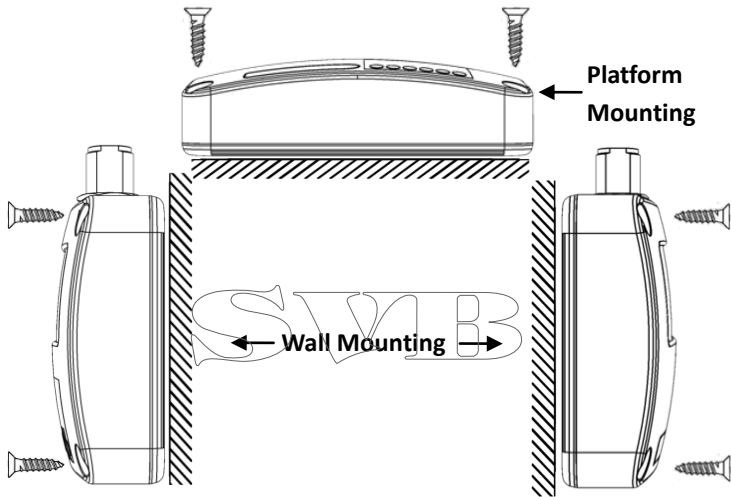
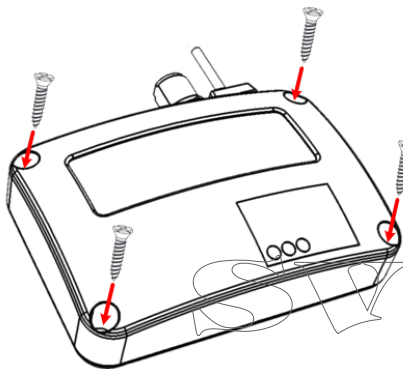

Figure 6 Mounting Instructions (1)



Step 1:

Place the Receiver on the desired location for installing.
(Refer to figure 6)

Step 2:

Use the provided M3.5x25 screws to mount.
(Refer to figure 6)

Figure 7 Mounting Instructions (2)

3.5 Wiring Instructions

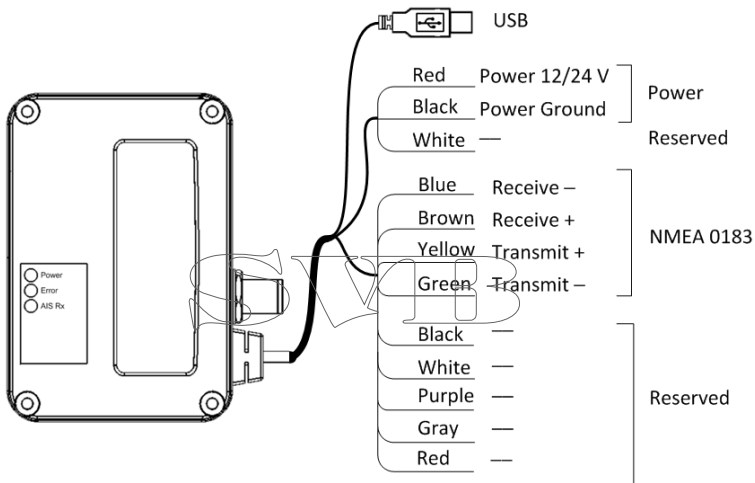

Figure 8 **Wiring Instructions**

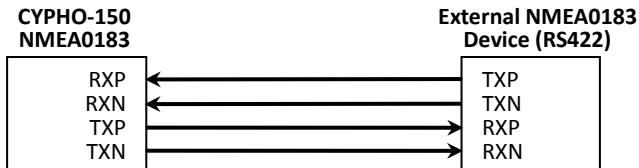

Figure 9 NMEA0183 Connection illustration

| Core Color at CYPHO-150 | NMEA 0183 Signal | Signal Direction (CYPHO-150) | External NMEA0183 Device |
|-------------------------|---------------------|------------------------------|--------------------------|
| Brown | Data Input + (RXP) | Input | Data Output + (TXP) |
| Blue | Data Input - (RXN) | Input | Data Output - (TXN) |
| Yellow | Data Output + (TXP) | Output | Data Input + (RXP) |
| Green | Data Output - (TXN) | Output | Data Input - (RXN) |

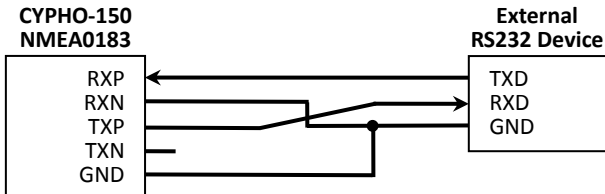

Figure 10 NMEA0183 to RS232 Connection

| Core Color at CYPHO-150 | NMEA 0183 Signal | Signal Direction (CYPHO-150) | External RS-232 Device |
|-------------------------|---------------------|------------------------------|------------------------|
| Brown | Data Input + (RXP) | Input | Data Output (TXD) |
| Blue | Data Input - (RXN) | - | Ground |
| Yellow | Data Output + (TXP) | Output | Data Input (RXD) |
| Black | Power Ground, (GND) | - | Ground |

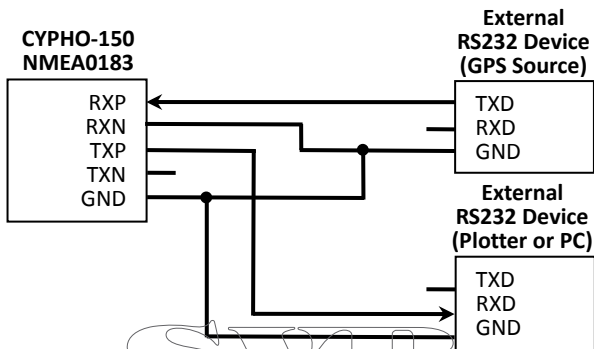

Figure 11 NMEA0183 to RS232 Connection (Multiplexing)

| Core Color at CYPHO-150 | Description (NMEA 0183 Signal) | Signal Direction (CYPHO-150) | External RS-232 Devices |
|-------------------------|--------------------------------|------------------------------|------------------------------|
| Brown | Data Input + (RXP) | Input | Data Output @ Device 1 (TXD) |
| Blue | Data Input - (RXN) | - | Ground @ Device 1 (GND) |

| | | | |
|--------|------------------------|--------|--------------------------------|
| Black | Power Ground (GND) | - | Ground @ Device 1 (GND) |
| Yellow | Data Output + (TXP) | Output | Data Input @ Device 2 (RXD) |
| Blue | Data Input – (RXN) | - | Ground @ Device 2 (GND) |
| Black | Power Ground (GND) | - | Ground @ Device 2 (GND) |

When wiring NMEA0183 to AIS-ready equipment, please refer to your equipment manual first. CYPHO-150 series supports three baud rates: 4800, 9600, and 38400. The default baud rate is 38400. Use the provided configuration utility to change baud rates.

3.6 VHF Antenna Installation

The quality and positioning of the antenna is the most important factor dictating AIS performance. It is recommended that a VHF antenna with omni-directional vertical polarization and specifically tuned for AIS operation band is used. Since the range of VHF signals is largely decided by line of sight distance, AIS antenna should be placed as high as possible and at least 5 meters away from any constructions made of conductive materials.

To avoid interference, the VHF antenna location should be placed in accordance to figure 12.



The safe distance from a transmitting VHF antenna is 60cm.

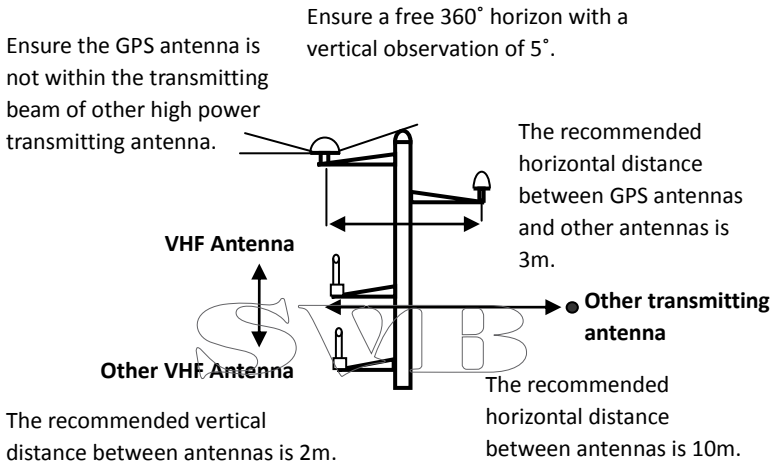

Figure 12 VHF Antenna Installation



We recommend choosing AMEC AIS VHF antenna.

3.7 Antenna Cabling

When connecting the cable(s) with the CYPHO-150, take note of the following precautions.



DO NOT BEND CABLES

Bending cables may cause damages to the inner wires and impair overall the performances.



USES OF CABLE TUBE

Each coaxial cable should be set up separately and can only be set up in a single cable tube.



INSULATION ON CONNECTING PORT

Connecting port of the coaxial cable should be insulated.

3.8 USB Driver Installation

Your PC needs to install the USB driver in able to connect the AIS receiver. Locate the USB driver in the CD-ROM. Follow the instructions below to finish the installation.

Step 1: Open the USB Driver file and double click on USBDriverInstaller.exe to install the driver. Please click on Install Drivers to continue.

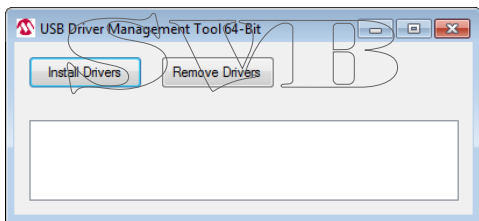

Figure 13 USB Driver Installation (1)

Step 2: A security reminder appears and asks for your confirmation. Click Install to proceed.

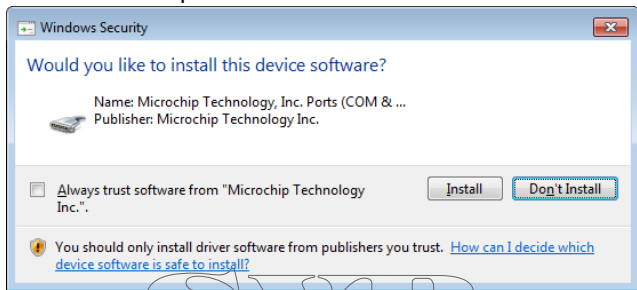

Figure 14 USB Driver Installation (2)

Step 3: Driver installation is completed. Close the window directly using the close window icon.

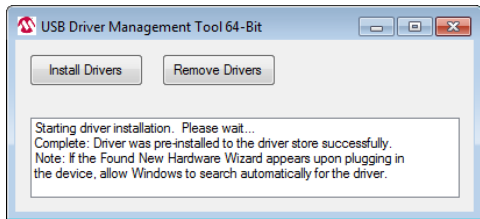

Figure 15 USB Driver Installation (3)

3.9 CYPHO Configuration Software

3.9.1 Software Installation

Find the installation software AmecCyphoConfigPro.exe from the CD-ROM.

Step1: Double click on the application

Step2: You may either connect the receiver automatically or manually by using the determined USB serial port number assigned by the PC.

SVTB

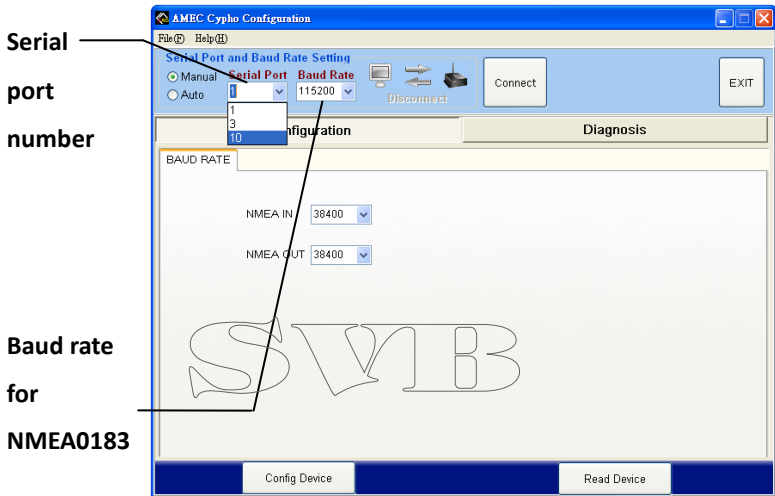

Figure 16 Software Installation (1)

To find the serial port number, click Start → Control Panel → Device Manager. Expand the Ports section and look for USB Communications Port. In the sample picture below, the serial port number is 30.

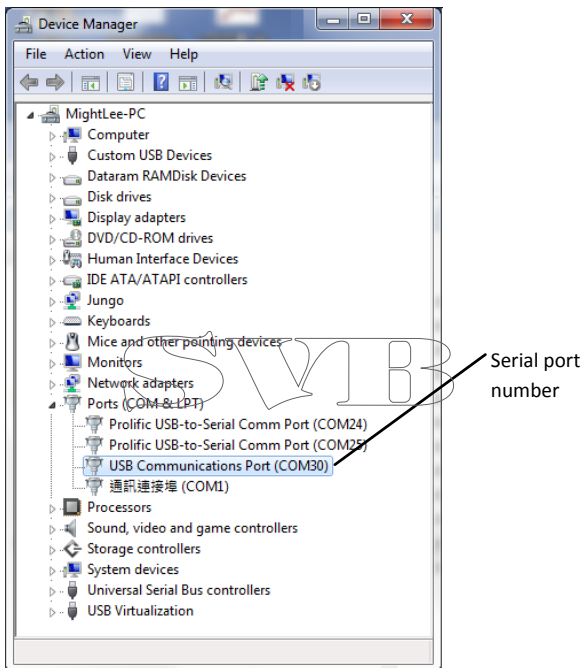

Figure 17 Software Installation (2)

Enter the value and hit “Connect” to link the computer to the receiver.

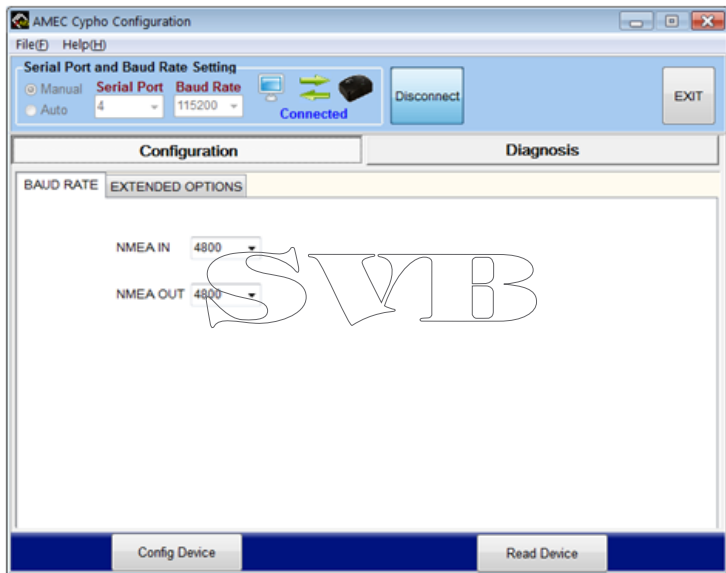

Figure 18 Software Installation (3)

3.9.2 Configuration

The Configuration tab has two submenus, Baud Rates and Extended Options.

Baud Rates:

Each CYPHO-150 model has two independent NMEA 0138 ports and these can have different baud rate values.

To adjust the values, set the desired baud rates for the NMEA input and output and then click on “Config Device” to apply new the setting.

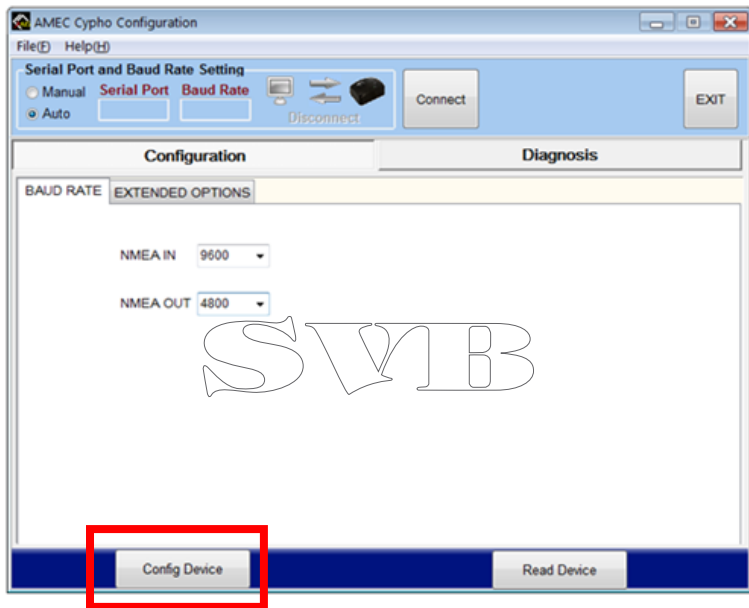

Figure 19 Baud Rates

3.9.3 Diagnosis

The Diagnosis tab has two submenus, System Check and Data Log.

System Check

System Check retrieves following information and statuses from the receiver: Firmware Version, Product Serial Number, RX position reports.

The logo consists of the letters 'S', 'V', 'M', and 'B' in a stylized, outlined font. The 'S' is on the left, followed by 'V', 'M', and 'B' to its right. The letters are interconnected and have a decorative, slightly irregular appearance.

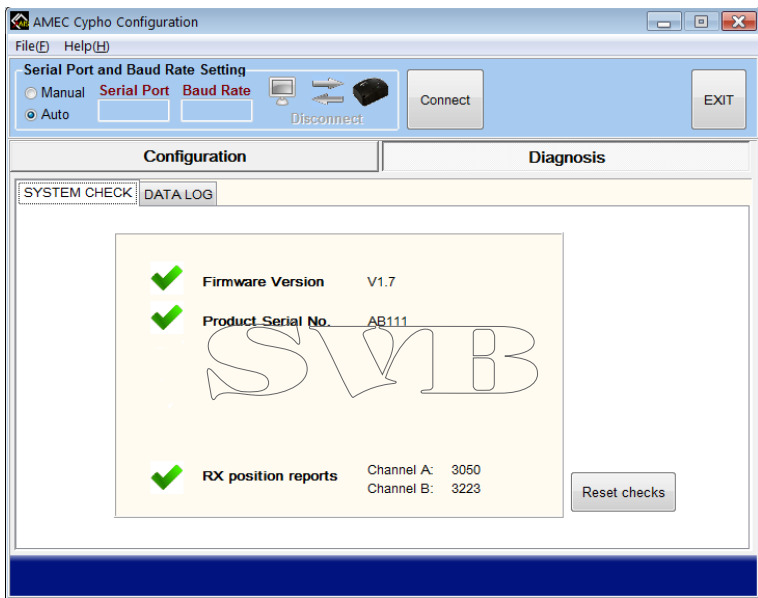

Figure 20 System Check

Data Log

The Data Log enables user to record received AIS information.

To enable or disable the recording of AIS information, use the “Enable Log” check box. Click “Save” to save the record at a preferred location on the PC via USB. To ensure the log is recorded the device must stay connected to the PC via USB and the AMEC CYPHO Configuration Software is running.

To clear the current listing, use the “Clear” button.



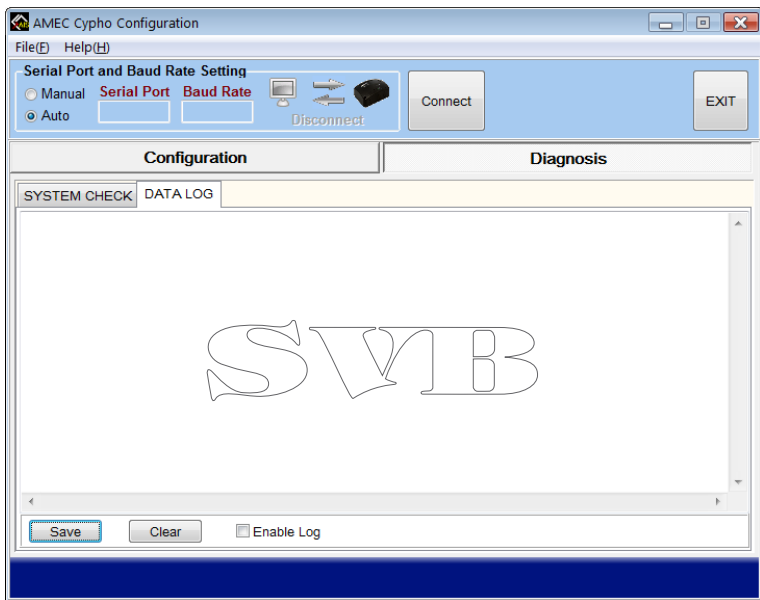

Figure 21 Data Log

3.10 NMEA 0183 Multiplexer

All CYPHO-150 models are designed with both NMEA 0183 input and output wiring.

Thus, the input and output ports support independent baud rates. For the advanced multiplexing configuration, CYPHO 150 series gets input from one NMEA0183 device and pass to another NMEA0183 device together with AIS information.

CYPHO-150 series supports three baud rates: 4800, 9600, and 38400. The default baud rate is 38400. Use the provided configuration utility to change the baud rates.

See the illustration Figure 22.

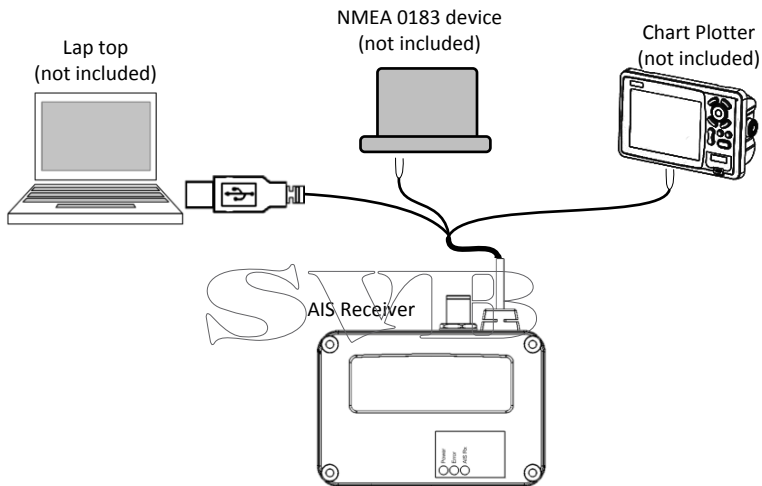

Figure 22 NMEA 0183 Multiplexer

3.11 AMEC AIS Viewer Software Installation

AIS Viewer is a supplementary application that provides a simple access for user to view AIS information on PC. The application provides basic features to browse the relative positions of surrounding vessels and the dynamic and static information regulated by IMO. For professional uses, we recommend connecting AMEC CYPHO-150 Series with other marine electronic products such as ECS or Radar for better performances.

The program (AMEC AIS Viewer.exe) and its operation manual are included in the CD-ROM.

4 APPENDIX

4.1 Product Specifications

| APPLICABLE STANDARDS | |
|---------------------------------|-----------------------------|
| IEC 62287-1 (applicable parts) | |
| ITU-R M.1371 (applicable parts) | |
| IEC 60945 (applicable parts) | |
| IEC 61162 (applicable parts) | |
| AIS RECEIVER | |
| Number of AIS Receivers | 2 channels |
| CH-1 | Default CH 87B (161.975MHz) |
| CH-2 | Default CH 88B (162.025MHz) |
| Channel Bandwidth | 25KHz |
| Message Format | AIS Class A & B messages |
| Data Rate | 9,600bps / per channel |
| AIS Receiver Sensitivity | -112dBm |
| Max. Usable Sensitivity | PER \leq 20% @ -107 dBm |
| POWER SUPPLY | |
| Supply Voltage | 12 / 24V DC |
| Power Consumption | <1.50 Watt |

| LED INDICATION | |
|--|---------------------------------|
| CYPHO-150 | Power, Error, AIS Rx |
| CYPHO-150S | Power, Error, AIS Rx, Radio Tx |
| INTERFACE | |
| VHF Antenna Connector | Female Type M (PL 259) |
| NMEA 0183 | 38400 (default), 9600, 4800 bps |
| USB 2.0 | Supported |
| VHF Radio Connector (CYPHO-150S/150WS only) | Female Type M (PL 259) |
| ENVIRONMENTAL | |
| Operating Temperature | -15°C~55°C |
| Storage Temperature | -25°C~70°C |
| Humidity Operation | 0~95% RH at 40°C |
| Vibration | IEC 60945 |
| Waterproof | IPX2 |

| PHYSICAL | |
|--------------------------------------|--|
| Size in mm (w) | 128 mm |
| Size in mm (h) | 36 mm |
| Size in mm (d) | 88 mm |
| Weight | 210g (incl. cable) |
| Cable Length (power, USB, NMEA 0183) | 1M |
| RF PERFORMANCE (CYPHO-150S only) | |
| Frequency Range | 156.025 ~ 162.025 MHz |
| AIS Receiver Sensitivity | -110dBm (when not connecting to DSC) |
| VHF Port Insertion Loss | Receiver Path: 3.5dB Transmit Path: 1.2dB |
| Certification | |
| CE, FCC | |

4.2 Dimensions

Applicable to all CYPHO-150 models.

Front View

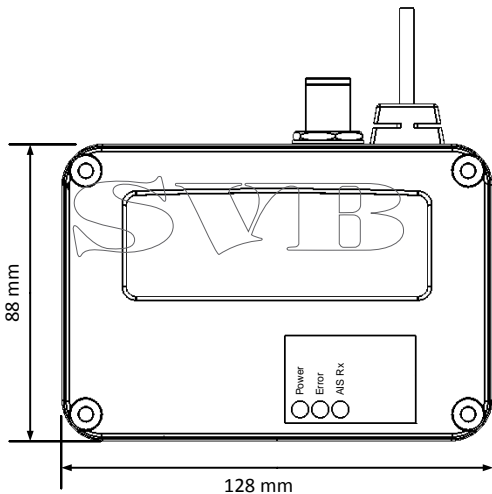

Figure 23 Front View

Side View

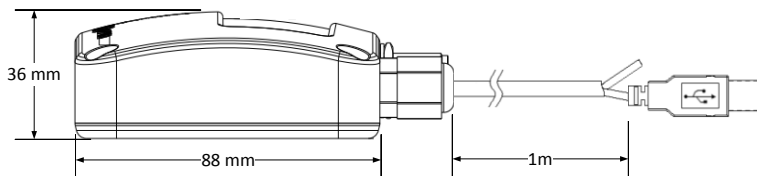

Figure 24 Side View

4.3 Accessories (Optional)

The following accessories are available from AMEC. Contact our local dealer/agent for more details.

| Item | Description | Product Code | Remark |
|------|-------------|--------------|------------------|
| 1 | VHF Antenna | TENTA-11 | Length: 1,200 mm |

Limited warranty

Subject to the terms, conditions and limitations set forth in this Worldwide Limited Warranty (hereinafter the “Warranty”), AMEC warrants that its products, when properly installed and used, will be free from defects in material and workmanship for a period of twelve (12) months, from the date of first purchase (the ‘Warranty Period’)

For the purposes of this warranty, ‘date of first purchase’ means the date that the product was purchased by the first retail customer, or by the institutional customer, or in the case of a product installed on a new vessel or any other marine related platform by a certified AMEC original equipment manufacturer (a ‘AMEC OEM’), the date that such vessel was purchased by the first retail customer.

AMEC will, at its sole option, repair or replace any defective products or components returned during the Warranty Period in accordance with the terms, conditions and limitations set forth below. Such repairs or replacement will be the sole remedy of the customer under this Warranty.

Standard Warranty Service

To qualify for standard warranty service the product must be returned to a AMEC-certified service agent (i) within the Warranty Period, and (ii) within thirty (30) days of the alleged product failure. Any products returned must be securely packaged and sent pre-paid and insured to AMEC or to a AMEC-certified service agent. All products returned must be accompanied by a copy of the original sales receipt to be eligible for standard warranty service.

Other conditions

This Warranty is fully transferable provided that you furnish the original proof of purchase to the AMEC -certified service agent. This Warranty is void if the seal label is removed or defaced.

THE LIABILITY OF AMEC TO A CUSTOMER UNDER THIS WARRANTY, WHETHER FOR BREACH OF CONTRACT, TORT, BREACH OF STATUTORY DUTY OR OTHERWISE SHALL IN NO EVENT EXCEED AN AMOUNT EQUAL TO THE TOTAL PURCHASE PRICE OF THE PRODUCT GIVING RISE TO SUCH LIABILITY AND IN NO EVENT SHALL AMEC BE LIABLE FOR SPECIAL, INCIDENTAL, CONSEQUENTIAL OR INDIRECT DAMAGES OR

LOST OF GOODWILL, REPUTATION, LOSS OF OPPORTUNITY OR INFORMATION, DATA, SOFTWARE OR APPLICATIONS.

In the event that any term or provision contained in this Warranty is found to be invalid, illegal or unenforceable by a court of competent jurisdiction, then such provision shall be deemed modified to the extent necessary to make such provision enforceable by such court, taking into account the intent of the parties.

All AMEC products sold or provided hereunder are merely aids to navigation. It is the responsibility of the user to exercise discretion and proper navigational skill independent of any AMEC product.

SVTB

5 FCC INTERFERENCE STATEMENT

This equipment has been tested and found to comply with the limits for a Class A digital device, pursuant to Part 15 of FCC Rules. These limits are designed to provide reasonable protection against harmful interference in a residential installation. This equipment generates uses and can radiate radio frequency energy and, if not installed and used in accordance with the instructions, may cause harmful interference to radio communications. However, there is no guarantee that interference will not occur in a particular installation. If this equipment does cause harmful interference to radio or television reception, which can be determined by turning the equipment off and on, the user is encouraged to try to correct the interference by one of the following measures:

- Reorient or relocate the receiving antenna.
- Increase the separation between the equipment and receiver.
- Connect the equipment into an outlet on a circuit different from that to which the receiver is connected.
- Consult the dealer or an experienced radio/TV technician for help.

This device complies with Part 15 of the FCC Rules. Operation is subject to the following two conditions: 1) This device may not cause harmful interference, and 2) this device must accept any interference received, including interference that may cause undesired operation.

6 DECLARATION OF CONFORMITY

Hereby, Alltek Marine Electronics Corp. (AMEC) declares that this CYPHO-150/150S is in compliance with the essential requirements and other relevant provisions of Directive 1999/5/EC.

The logo consists of the letters 'S', 'V', and 'B' in a stylized, outlined font. The 'S' is on the left, the 'V' is in the middle, and the 'B' is on the right. The letters are interconnected and have a decorative, slightly calligraphic appearance.

7 ACRONYMS

| | |
|---------------|---|
| AIS | Automatic Identification System |
| COG | Course Over Ground |
| CPA | Distance to Closest Point of Approach |
| CSTDMA | Carrier-sense time division multiple access |
| DSC | Digital Selective Calling |
| ECS | Electronic Chart System |
| ETA | Estimated Time of Arrival |
| GPS | Global Positioning System |
| IMO | International Maritime Organization |
| MMSI | Maritime Mobile Service Identity |
| SOG | Speed Over Ground |
| SRM | Safety Related Message |
| TCPA | Time to Closest Point of Approach |
| TDMA | Time Division Multiple Access |
| UTC | Coordinated Universal Time |
| VHF | Very High Frequency |
| VTS | Vessel Traffic Service |



Alltek Marine Electronics Corp

7F, No. 605, Rwei Guang Road
Neihu, Taipei, 11492, Taiwan

Tel: +886 2 2627 1599

Fax: +886 2 2627 1600

Email: service@alltekmarine.com

Website: www.alltekmarine.com