



# RV-100

TRANSOM REALVISION™ 3D SONAR TRANSDUCER

---

## INSTALLATION INSTRUCTIONS

English (en-US)  
Date: 01-2023  
Document number: 87337 (Rev 3)  
© 2023 Raymarine UK Limited

**Raymarine®**



## Trademark and patents notice

**Raymarine, Tacktick, Clear Pulse, Truzoom, SeaTalk, SeaTalk<sup>hs</sup>, SeaTalkng**, and **Micronet**, are registered or claimed trademarks of Raymarine Belgium.

**FLIR, YachtSense, DockSense, LightHouse, RangeFusion, DownVision, SideVision, RealVision, HyperVision, Dragonfly, Element, Quantum, Axiom, Instalert, Infrared Everywhere, The World's Sixth Sense** and **ClearCruise** are registered or claimed trademarks of FLIR Systems, Inc.

All other trademarks, trade names, or company names referenced herein are used for identification only and are the property of their respective owners.

This product is protected by patents, design patents, patents pending, or design patents pending.

## Fair Use Statement

You may print no more than three copies of this manual for your own use. You may not make any further copies or distribute or use the manual in any other way including without limitation exploiting the manual commercially or giving or selling copies to third parties.

## Software updates



Check the Raymarine website for the latest software releases for your product.  
[www.raymarine.com/software](http://www.raymarine.com/software)

## Product documentation



The latest versions of all English and translated documents are available to download in PDF format from the website:  
[www.raymarine.com/manuals](http://www.raymarine.com/manuals).  
Please check the website to ensure you have the latest documentation.



# CONTENTS

<b>CHAPTER 1 IMPORTANT INFORMATION .....</b>	<b>7</b>		
Certified Installation .....	7		
Declaration of conformity .....	7		
Water ingress .....	7		
Disclaimer .....	7		
Warranty registration.....	8		
Product disposal .....	8		
IMO and SOLAS .....	8		
Technical accuracy .....	8		
Publication copyright.....	9		
<b>CHAPTER 2 DOCUMENT AND PRODUCT INFORMATION .....</b>	<b>10</b>		
2.1 Document information .....	11		
Applicable products.....	11		
Document illustrations .....	11		
2.2 Product overview .....	11		
2.3 Product documentation .....	12		
Operation instructions .....	12		
LightHouse™ MFD Operation instructions.....	12		
<b>CHAPTER 3 PLANNING THE INSTALLATION .....</b>	<b>13</b>		
3.1 Installation checklist.....	14		
Schematic diagram .....	14		
Warnings and cautions .....	14		
3.2 Parts supplied .....	14		
3.3 Required additional components.....	15		
		Compatible RealVision™ 3D products.....	15
		3.4 Tools required .....	16
		3.5 Location requirements .....	16
		3.6 Transducer dimensions .....	18
		<b>CHAPTER 4 CABLES AND CONNECTIONS .....</b>	<b>19</b>
		4.1 General cabling guidance.....	20
		Cable types and length .....	20
		Strain relief .....	20
		Cable shielding.....	20
		4.2 Transducer cable routing guidance.....	20
		RealVision™ 3D transducer extension	
		cable .....	20
		<b>CHAPTER 5 MOUNTING .....</b>	<b>21</b>
		5.1 Pre-installation test.....	22
		Testing the transducer.....	22
		5.2 Mounting the transom mount bracket .....	22
		5.3 Mounting the transducer .....	23
		5.4 Attaching the connector locking collar.....	24
		5.5 Making connections.....	25
		RealVision™ 3D transducer extension	
		cable .....	25
		5.6 Mounting the escutcheon plate .....	25
		5.7 Testing and adjusting the transducer .....	26
		5.8 Finalizing the transducer mounting .....	27

CHAPTER 6 SYSTEM CHECKS AND TROUBLESHOOTING.....	28
6.1 RealVision™ AHRS calibration.....	29
6.2 Troubleshooting .....	29
Operation instructions .....	29
Sonar troubleshooting.....	30
Resetting the sonar module .....	32
CHAPTER 7 MAINTENANCE .....	33
7.1 Routine checks.....	34
7.2 Unit cleaning instructions.....	34
Transducer cleaning.....	34
CHAPTER 8 TECHNICAL SUPPORT .....	35
8.1 Raymarine product support and servicing.....	36
Viewing product information.....	37
8.2 Learning resources.....	37
CHAPTER 9 TECHNICAL SPECIFICATION .....	38
9.1 Technical specification .....	39
Physical specification .....	39
Environmental specification .....	39
RealVision™ 3D sonar specification .....	39
Sonar range .....	39
Conformance specification.....	39
CHAPTER 10 SPARES AND ACCESSORIES .....	40
10.1 Accessories.....	41

# CHAPTER 1: IMPORTANT INFORMATION

## Certified Installation

Raymarine recommends certified installation by a Raymarine approved installer. A certified installation qualifies for enhanced product warranty benefits. Contact your Raymarine dealer for further details, and refer to the separate warranty document packed with your product.



### Warning: Product installation and operation

- This product must be installed and operated in accordance with the instructions provided. Failure to do so could result in personal injury, damage to your vessel and/or poor product performance.
- Raymarine highly recommends certified installation by a Raymarine approved installer. A certified installation qualifies for enhanced product warranty benefits. Register your warranty on the Raymarine website: [www.raymarine.com/warranty](http://www.raymarine.com/warranty)



### Warning: High voltage

This product contains high voltage. Do NOT remove covers or attempt to access internal components, unless specifically instructed in the documentation provided.



### Warning: Positive ground systems

Do not connect this unit to a system which has positive grounding.



### Warning: Switch off power supply

Ensure the vessel's power supply is switched OFF before starting to install this product. Do NOT connect or disconnect equipment with the power switched on, unless instructed in this document.



### Warning: Transducer operation

Only test and operate the transducer in the water. Do NOT operate out of water as overheating may occur.



### Warning: Marine-grade sealant

Only use marine-grade neutral cure polyurethane sealants. Do NOT use sealants containing acetate or silicone, which can cause damage to plastic parts.

### Caution: Service and maintenance

This product contains no user serviceable components. Please refer all maintenance and repair to authorized Raymarine dealers. Unauthorized repair may affect your warranty.

## Declaration of conformity

Raymarine UK Limited declares that this product is compliant with the essential requirements of EMC Directive 2014/30/EU.

The original Declaration of Conformity certificate may be viewed on the relevant product page at [www.raymarine.com/manuals](http://www.raymarine.com/manuals)

## Water ingress

Water ingress disclaimer

The waterproof rating capacity of this product meets the stated Ingress Protection (IP) standard referred to in the product's *Technical Specification*.

## Disclaimer

Raymarine does not warrant that this product is error-free or that it is compatible with products manufactured by any person or entity other than Raymarine.

Raymarine is not responsible for damages or injuries caused by your use or inability to use the product, by the interaction of the product with products manufactured by others, or by errors in information utilized by the product supplied by third parties.

Third-party hardware, such as converters, adapters, routers, switches, Access Points etc., provided by third parties, may be made available directly to you by other companies or individuals under separate terms and conditions, including separate fees and charges. Raymarine UK Limited or its affiliates have not tested or screened the third-party hardware.

Raymarine has no control over, and is not responsible for:

- (a) the content and operation of such third-party hardware; or
- (b) the privacy or other practices of such third-party hardware.

The fact that Raymarine's documentation may make reference to such third-party hardware does not indicate any approval or endorsement of any such third-party hardware. Raymarine may reference such third-party hardware only as a convenience.

**THIS INFORMATION IS MADE AVAILABLE BY RAYMARINE UK LIMITED ON THE BASIS THAT YOU EXCLUDE TO THE FULLEST EXTENT LAWFULLY PERMITTED ALL LIABILITY WHATSOEVER FOR ANY LOSS OR DAMAGE HOWSOEVER ARISING OUT OF THE USE OF THIS INFORMATION OR RELIANCE UPON THIS INFORMATION.**

**Raymarine UK Limited** does not exclude **Raymarine UK Limited's** liability (if any) to you for personal injury or death resulting from **Raymarine UK Limited's** negligence, for fraud or for any matter which it would be illegal to exclude or to attempt to exclude.

## Warranty registration

To register your Raymarine product ownership, please visit [www.raymarine.com](http://www.raymarine.com) and register online.

It is important that you register your product to receive full warranty benefits. Your unit package includes a bar code label indicating the serial number of the unit. You will need this serial number when registering your product online. You should retain the label for future reference.

## Product disposal

Dispose of this product in accordance with the WEEE Directive.

The Waste Electrical and Electronic Equipment (WEEE) Directive requires the recycling of waste electrical and electronic equipment which contains materials, components and substances that may be hazardous and present a risk to human health and the environment when WEEE is not handled correctly.

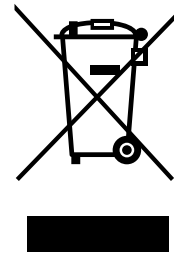

Equipment marked with the crossed-out wheeled bin symbol indicates that the equipment should not be disposed of in unsorted household waste. Local authorities in many regions have established collection schemes under which residents can dispose of waste electrical and electronic equipment at a recycling center or other collection point. For more information about suitable collection points for waste electrical and electronic equipment in your region, refer to the Raymarine website: [www.raymarine.eu/recycling](http://www.raymarine.eu/recycling).

## IMO and SOLAS

The equipment described within this document is intended for use on leisure marine boats and workboats NOT covered by International Maritime Organization (IMO) and Safety of Life at Sea (SOLAS) Carriage Regulations.

## Technical accuracy

To the best of our knowledge, the information in this document was correct at the time it was produced. However, Raymarine cannot accept liability for any inaccuracies or omissions it may contain. In addition, our policy of continuous product improvement may change specifications without notice. As a result, Raymarine cannot accept liability for any differences between the product and this document. Please check the Raymarine website ([www.raymarine.com](http://www.raymarine.com)) to ensure you have the most up-to-date version(s) of the documentation for your product.



## Publication copyright

**Copyright ©2023 Raymarine UK Ltd. All rights reserved. No parts of this material may be copied, translated, or transmitted (in any medium) without the prior written permission of Raymarine UK Ltd.**

# CHAPTER 2: DOCUMENT AND PRODUCT INFORMATION

## CHAPTER CONTENTS

- 2.1 Document information — page 11
- 2.2 Product overview — page 11
- 2.3 Product documentation — page 12

## 2.1 Document information

This document contains important information related to the installation of your Raymarine® product.

The document includes information to help you:

- Plan your installation and ensure you have all the necessary equipment.
- Install and connect your product as part of a wider system of connected marine electronics.
- Troubleshoot problems and obtain technical support if required.

This and other Raymarine® product documents are available to download in PDF format from [www.raymarine.com/manuals](http://www.raymarine.com/manuals)

### Applicable products

This document is applicable to the following products:

#### RV-100 RealVision™ 3D Transom Mount Transducer

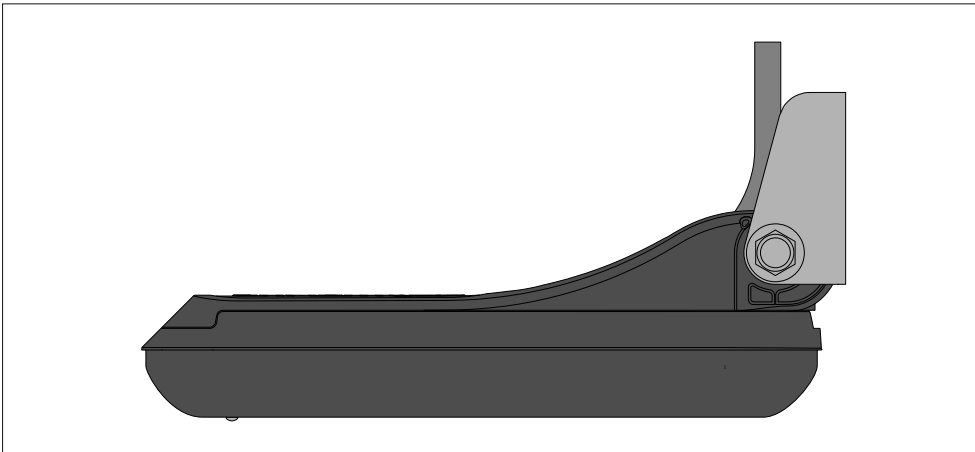

- **A80464** — **RV-100** RealVision™ 3D Transom Mount Transducer (Plastic).
- The **RV-100** is a RealVision™ 3D transducer, capable of producing 3D sonar images.
- The transducer can be connected to RealVision™ 3D or RealVision™ 3D Max variant MFDs running LightHouse™ 3 or LightHouse™ 4 software.

#### Note:

Additional mounting options are available for the transducer, including:

- Part number A80479: RealVision™ 3D Transducer Step Mount
- Part number A80480: RealVision™ 3D Transducer Jack Plate Mount
- Part number A80482: RealVision™ 3D Transducer Jack Plate Spacer Kit

For further mounting information, refer to the documentation supplied with these products.

### Document illustrations

Your product and if applicable, its user interface may differ slightly from that shown in the illustrations in this document, depending on product variant and date of manufacture.

All images are provided for illustration purposes only.

## 2.2 Product overview

The RV-100 is a transom-mounted RealVision™ 3D sonar transducer capable of producing realistic 3D representations of the objects below your vessel, to help you identify underwater structures and locate fish.

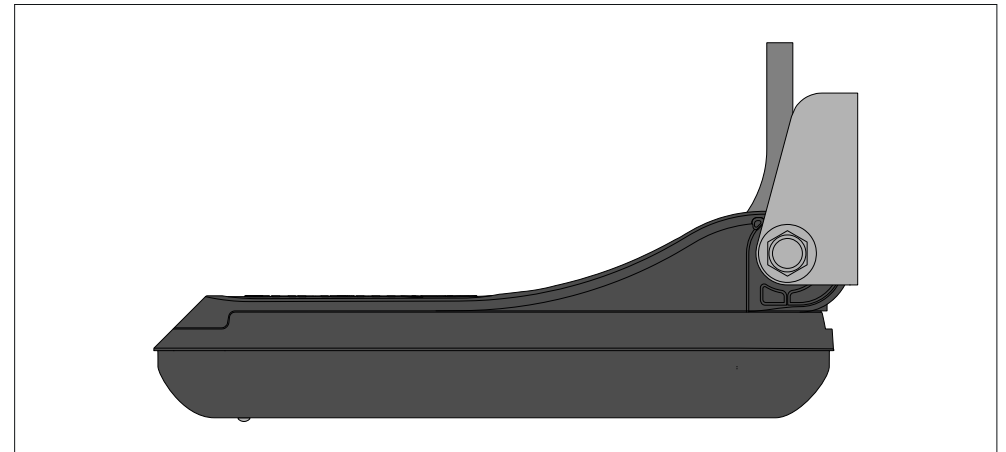

- 4 sonar channels: DownVision™, SideVision™, CHIRP, and RealVision™ 3D sonar technology combined in a single unit.

- Powerful and practical sonar operating ranges:
  - CHIRP sonar = 0.6 M (2 ft) to 274 m (900 ft)
  - DownVision™ = 0.6 M (2 ft) to 183 m (600 ft)
  - SideVision™ = 0.6 M (2 ft) to 91 m (300 ft)
  - RealVision™ 3D = 0.6 M (2 ft) to 91 m (300 ft)
- Built-in AHRS (Attitude and Heading Reference System) sensor helps to stabilize the sonar imaging, automatically compensating for vessel motion.
- Compact unit and transom mounting method for easy and flexible installation.
- Includes 8 m (26.2 ft) cable.
- Waterproof to IPX6, IPX7, IPX8.

## 2.3 Product documentation

The following documentation is applicable to your product:

All documents are available to download as PDFs from [www.raymarine.com/manuals](http://www.raymarine.com/manuals)

### Documentation

Description	Part number
Installation instructions (this document)	87337
RV-100 Transducer Mounting template	87294
RV-100 Hull / Step Bracket Installation instructions	87305
RV-100 Jack Plate Mount and Spacer Kit Installation instructions	87306

Description	Part number
<b>LightHouse™ 3</b> Advanced Operation instructions. Includes advanced operation instructions for the Sonar application on your MFD.	81370
<b>LightHouse™ 4</b> Advanced Operation instructions. Includes advanced operation instructions for the Sonar application on your MFD.	81406

### Operation instructions

For detailed operation instructions for your product, refer to the documentation that accompanies your display.

All product documentation is available to download from the Raymarine website: [www.raymarine.com/manuals](http://www.raymarine.com/manuals).

### LightHouse™ MFD Operation instructions

For operation instructions for your product please refer to the relevant LightHouse™ advanced operation instructions.



- **81406** — LightHouse™ 4 advanced operation instructions.
- **81370** — LightHouse™ 3 advanced operation instructions.

The operation instructions can be downloaded from the Raymarine website: [www.raymarine.com/manuals](http://www.raymarine.com/manuals). Please check the website to ensure you have the latest documentation.

# CHAPTER 3: PLANNING THE INSTALLATION

## CHAPTER CONTENTS

- 3.1 Installation checklist — page 14
- 3.2 Parts supplied — page 14
- 3.3 Required additional components — page 15
- 3.4 Tools required — page 16
- 3.5 Location requirements — page 16
- 3.6 Transducer dimensions — page 18

## 3.1 Installation checklist

Installation includes the following activities:

### Installation Task

1. Plan your system.
2. Obtain all required equipment and tools.
3. Site all equipment.
4. Route all cables.
5. Drill cable and mounting holes.
6. Make all connections into equipment.
7. Secure all equipment in place.
8. Power on and test the system.

### Schematic diagram

A schematic diagram is an essential part of planning any installation. It is also useful for any future additions or maintenance of the system. The diagram should include:

- Location of all components.
- Connectors, cable types, routes and lengths.

### Warnings and cautions

#### Important:

Before proceeding, ensure that you have read and understood the warnings and cautions provided in the following section of this document:  
[p.7 – Important information](#)

## 3.2 Parts supplied

The following parts are supplied in the box.

Unpack your product carefully to prevent damage or loss of parts. Check the box contents against the list below. Retain the packaging and documentation for future reference.

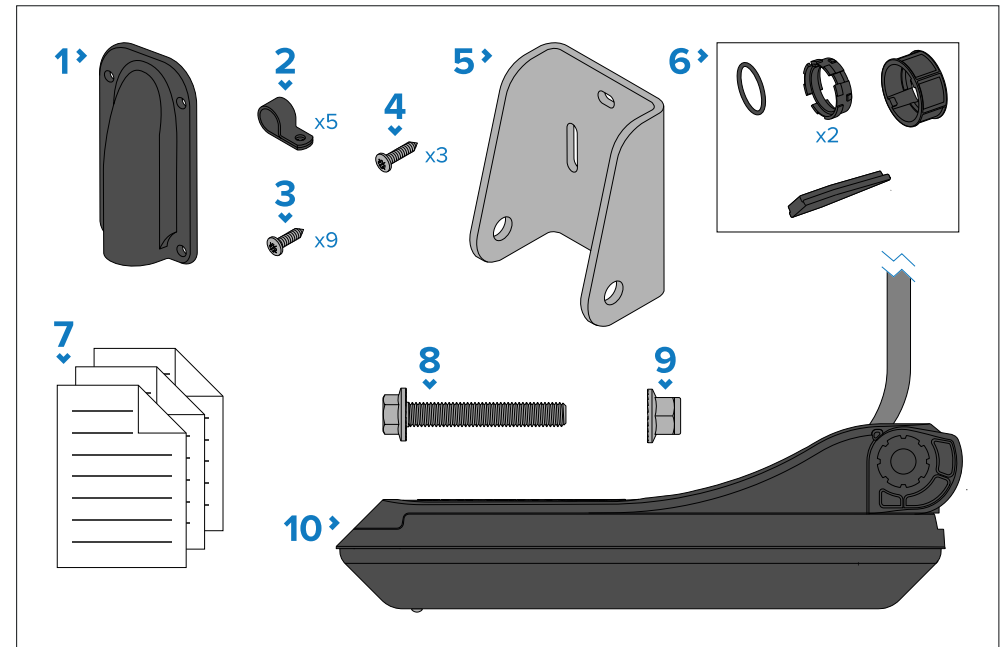

Item	Description
1	Escutcheon plate
2	5 x Cable clips
3	9 x Self tapper screw (3.9x13) (4 x for escutcheon and 5 x for cable clips)
4	3 x Self tapper screw (4.2x18) (for transducer mounting bracket installation)
5	Transducer mounting bracket
6	Cable connector kit, consisting of: <ul style="list-style-type: none"> <li>• O Ring</li> <li>• Split ring x 2 (1 x spare)</li> <li>• Locking collar</li> <li>• Split ring fitting tool</li> </ul>
7	Documentation pack
8	M10 x 65 serrated bolt

Item	Description
9	M10 serrated nylock nut
10	Transducer (including fitted 8 m / 26.2 ft cable)

### 3.3 Required additional components

This product forms part of a system of electronics and requires the following additional components for full operation.

- For a list of RealVision™ 3D sonar-capable devices, refer to: [Compatible RealVision™ 3D products](#)
- For longer cable runs, a transducer extension cable will also be required. For a list of suitable cables, refer to: [Chapter 10 Spares and accessories](#)

### Compatible RealVision™ 3D products

The transducer must be connected to a RealVision™ 3D sonar-capable device. The following RealVision™ and RealVision™ Max 3D sonar-capable products are compatible with the transducer.

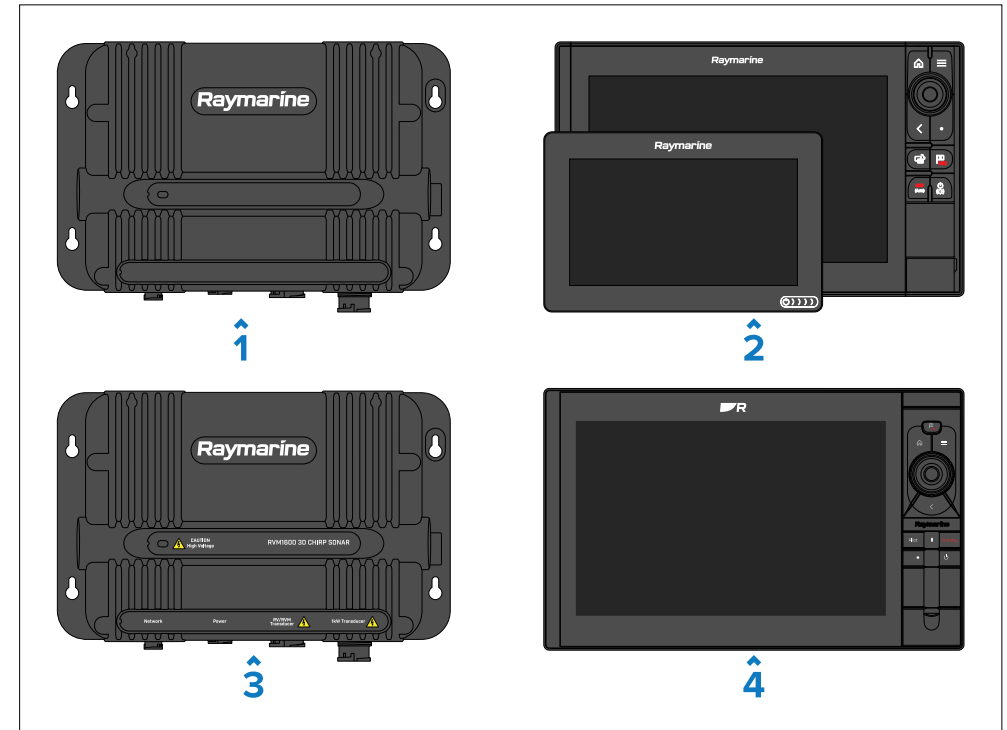

1. RVX1000 external RealVision™ 3D sonar module (a LightHouse™ 3 or LightHouse™ 4 compatible MFD is also required).
2. LightHouse™ 3 or LightHouse™ 4 compatible MFD with built in RealVision™ 3D sonar module (i.e.: Axiom, Axiom+ or Axiom Pro MFDs).
3. RVM1600 external RealVision™ 3D Max sonar module (a LightHouse™ 4 compatible MFD is also required).
4. LightHouse™ 4 compatible MFD with built in RealVision™ 3D Max sonar module (i.e.: Axiom 2 Pro RVM MFDs).

### 3.4 Tools required

The following tools are required to install your transducer.

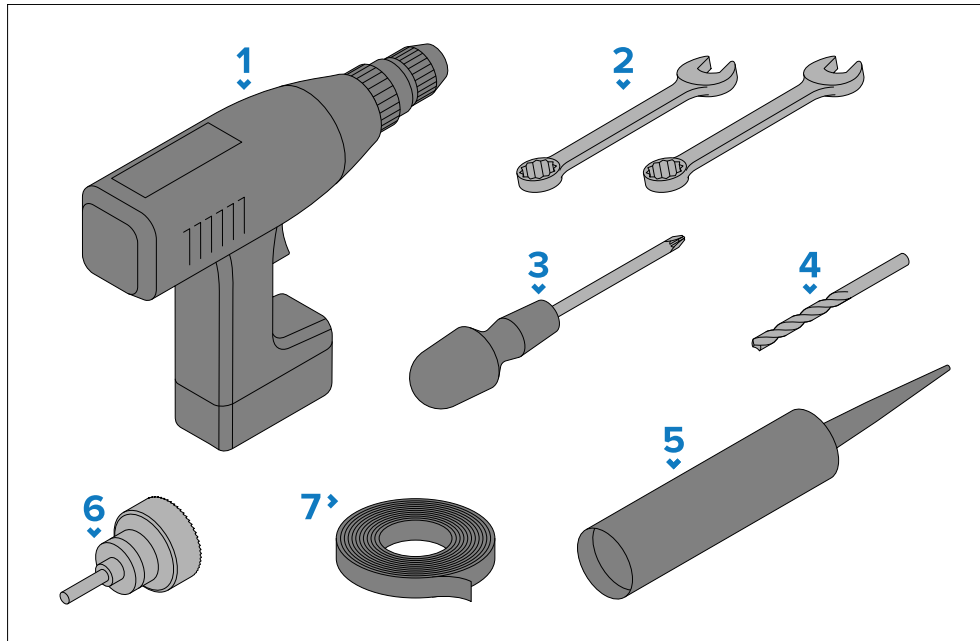

1. Power drill
2. 2 x 14 mm (9/16") wrenches or small adjustable wrenches.
3. Pozi-drive screw driver
4. Drill bit (suitable for pilot holes)

**Note:** The size of the drill bit required should be suitable for the fixings screws and the material and thickness of the mounting surface. Please refer to the parts supplied list for the fixing screws provided.

5. Marine-grade neutral cure polyurethane sealant (non-acetate and non-silicone based)
6. 25 mm (1 inch) Hole saw (only required if you are routing the cable through the transom and / or a bulkhead.)
7. Masking or Adhesive tape (Used to fix the mounting template to the mounting surface)

### 3.5 Location requirements

The guidelines below should be followed when selecting a location for the transducer.

**Note:**

The information below is provided for guidance only. Optimum transducer location will be different for each vessel, and **it is recommended that the transducer is tested in different mounting locations, to ensure optimum performance.**

- To obtain the best location for your transducer, observe the transom whilst underway and install in the area where the least amount of turbulence and aeration occurs.

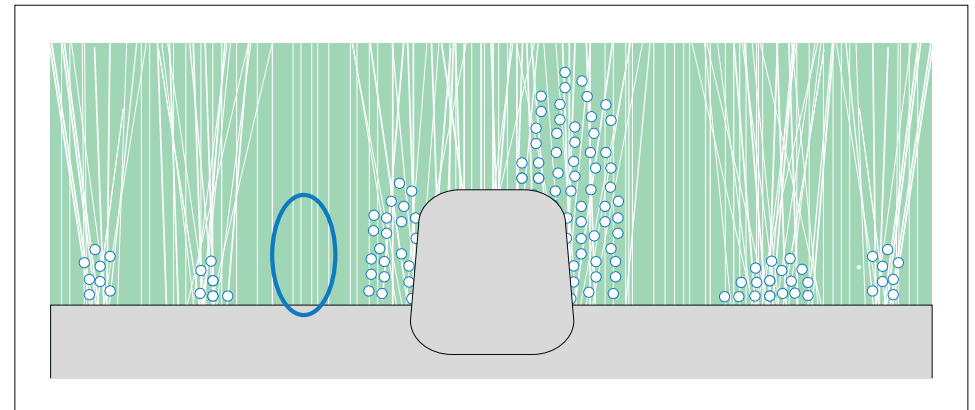

- The transducer is NOT suitable for mounting on vessels where the transom is aft of the propeller(s).

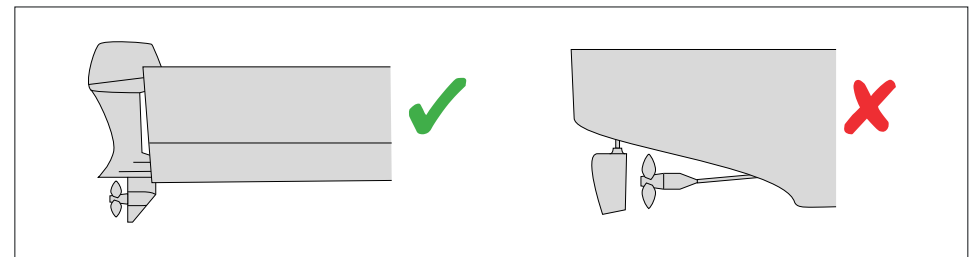

- The transducer should be mounted as close to the centerline as possible. However, if the centerline is pointed, the transducer should be offset from the centerline.



- For best performance the transducer must be installed in a location with the least turbulence and aeration. The most effective way to determine this is by checking the water flow around the transom whilst underway. Turbulence can be caused by chines (1), skegs (2), strakes, (3), outlets and exhausts (4), rows of rivets (5) steps (6), and ribs (7). Do NOT install your transducer aft of these locations or in areas of turbulence created by them.

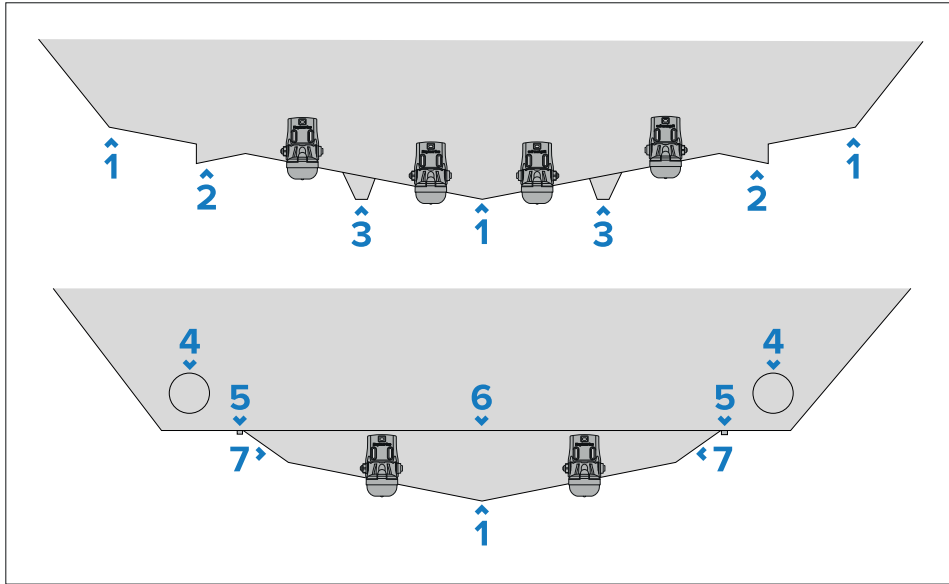

**Note:** The illustration above provides potential transducer locations for the hull types depicted. Before selecting a location, ensure that all location requirements have been met.

- The transducer should be mounted a minimum of 380 mm (15 in) away from the propeller. For clockwise rotating propellers, mount the transducer on the starboard side. For counter-clockwise, mount on the port side. On a twin engine vessel, mount the transducer close to the centerline or just offset from the centerline.

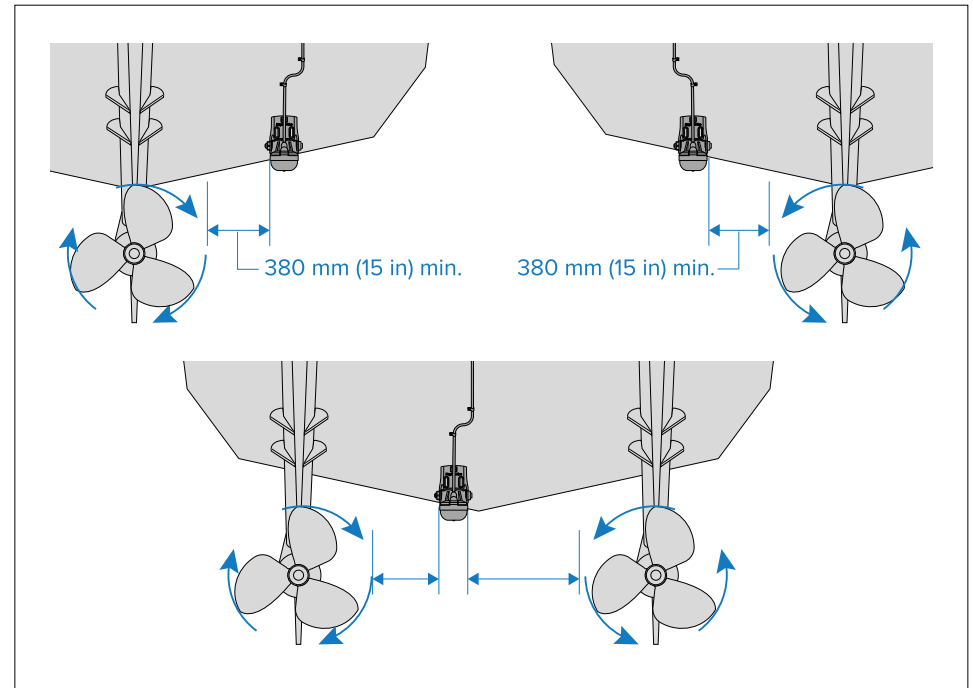

- The mounting location must ensure that the transducer element remains submerged when the vessel is planing and turning.
- The transducer should also be mounted in a location where no load will be applied to the transducer during launching, lifting, trailering, or storage of the vessel.

### 3.6 Transducer dimensions

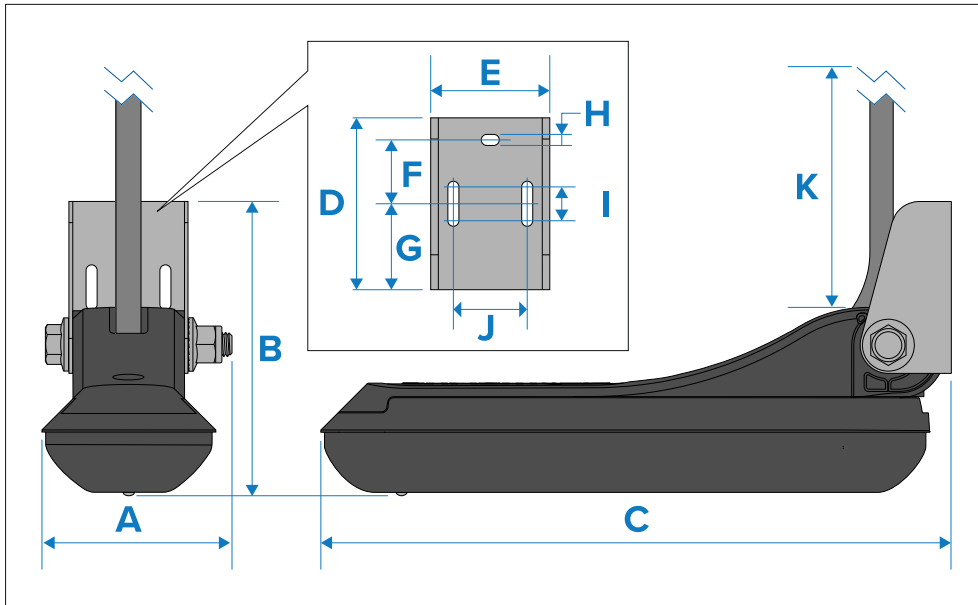

Item	Dimension
A	76.00 mm (3.00 in)
B	120.00 mm (4.72 in)
C	256.6 mm (10.10 in)
D	70.00 mm (2.76 in)
E	48.5 mm (1.91 in)
F	26.00 mm (1.01 in)
G	35.00 mm (1.38 in)
H	4.50 mm (0.18 in)
I	13.80 mm (0.54 in)
J	30.00 mm (1.18 in)
K	8 m (26.2 ft) fitted cable

# CHAPTER 4: CABLES AND CONNECTIONS

## CHAPTER CONTENTS

- 4.1 General cabling guidance — page 20
- 4.2 Transducer cable routing guidance — page 20

## 4.1 General cabling guidance

### Cable types and length

It is important to use cables of the appropriate type and length.

- Unless otherwise stated only use cables supplied by Raymarine.
- Where it is necessary to use non-Raymarine cables, ensure that they are of correct quality and gauge for their intended purpose. (e.g.: longer power cable runs may require larger wire gauges to minimize voltage drop along the run).

### Strain relief

Use adequate strain relief for cabling to ensure that connectors are protected from strain and will not pull out under extreme sea conditions.

### Cable shielding

Ensure that cable shielding is not damaged during installation and that all cables are properly shielded.

#### Caution: Transducer cable

- Do NOT use the transducer cable to lift or suspend the transducer; always support the transducer body directly during installation.
- Do NOT cut, shorten, or splice the transducer cable.
- Do NOT remove the connector.

If the cable is cut, it cannot be repaired. Cutting the cable will also void the warranty.

## 4.2 Transducer cable routing guidance

Guidance for routing your transducer's cable is provided below.

#### Important:

The transducer cable's connector is supplied with a separate locking collar assembly. Do NOT fit the locking collar assembly until after the cable has been routed to the display.

- The route the transducer cable will take to your MFD or sonar module should be planned before installing the transducer.
- The transducer is supplied with an 8 m (26.2 ft) fitted cable. If the cable length is too short then extension cables are available to lengthen the cable run.

**Note:** It is recommended that a maximum of two cable extensions are used, with the total cable length not exceeding 18 m (59 ft).

- The cable should be routed as far away as practical from VHF radio antennas and cabling.
- There should be sufficient slack is left at the transducer end to allow for the transducer to be tilted up and down.
- Any excess cable should be coiled up at a convenient location.
- The cable should be secured at regular intervals.

### RealVision™ 3D transducer extension cable

For best performance, cable runs should be kept to a minimum. However, for some installations it may be necessary to extend the transducer cable.

- RealVision™ transducer extension cable 3 m (9.8 ft) (part number A80475)
- RealVision™ transducer extension cable 5 m (16.4 ft) (part number A80476)
- RealVision™ transducer extension cable 8 m (26.2 ft) (part number A80477)

# CHAPTER 5: MOUNTING

## CHAPTER CONTENTS

- 5.1 Pre-installation test — page 22
- 5.2 Mounting the transom mount bracket — page 22
- 5.3 Mounting the transducer — page 23
- 5.4 Attaching the connector locking collar — page 24
- 5.5 Making connections — page 25
- 5.6 Mounting the escutcheon plate — page 25
- 5.7 Testing and adjusting the transducer — page 26
- 5.8 Finalizing the transducer mounting — page 27

## 5.1 Pre-installation test

### Testing the transducer

Transducer operation should be checked before installation. For the purposes of this test you do not need to assembly the connector locking collar.

For detailed information on using the Fishfinder / Sonar app please refer to the operation instructions for your MFD.

1. Connect the transducer to the relevant connector on your MFD or sonar module that is connected to your MFD.
2. Fully submerge the transducer in water.
3. Power up your MFD and / or Sonar module.
4. Open a Fishfinder / Sonar app on your MFD.
5. If required, select the relevant transducer from the Transducer settings tab (*[Menu > Transducer > Transducer]*).
6. If required, select the relevant channel from the Channel selection options (*[Menu > All channels]*).
7. Check that accurate depth and where applicable temperature readings are displayed.
8. If you experience difficulties obtaining readings then contact Raymarine® Technical Support.



#### **Warning: Transducer operation**

Only test and operate the transducer in the water. Do NOT operate out of water as overheating may occur.

## 5.2 Mounting the transom mount bracket

The transducer must be mounted on the transom using the mounting bracket provided. The steps below describe the initial mounting steps required in order to test your transducer's performance.

#### **Important:**

- Initially only the 2 holes for the height adjustment screws are required to secure the mounting bracket to the transom. The third screw is used to finalize the installation once the transducer has been tested and adjusted to obtain optimum performance.
- To help prevent chipping of fiberglass hulls, use painter's tape to mask the drill hole areas, behind the mounting template.

1. Fix the supplied transducer mounting template to the selected location, using masking or self-adhesive tape.
2. Ensure the template is parallel to the waterline.
3. Drill 2 x holes for the adjustment slot screws as indicated on the template.
4. Using a pozi-drive screw driver and the screws provided, secure the transom mount bracket using the 2 adjustment slots.

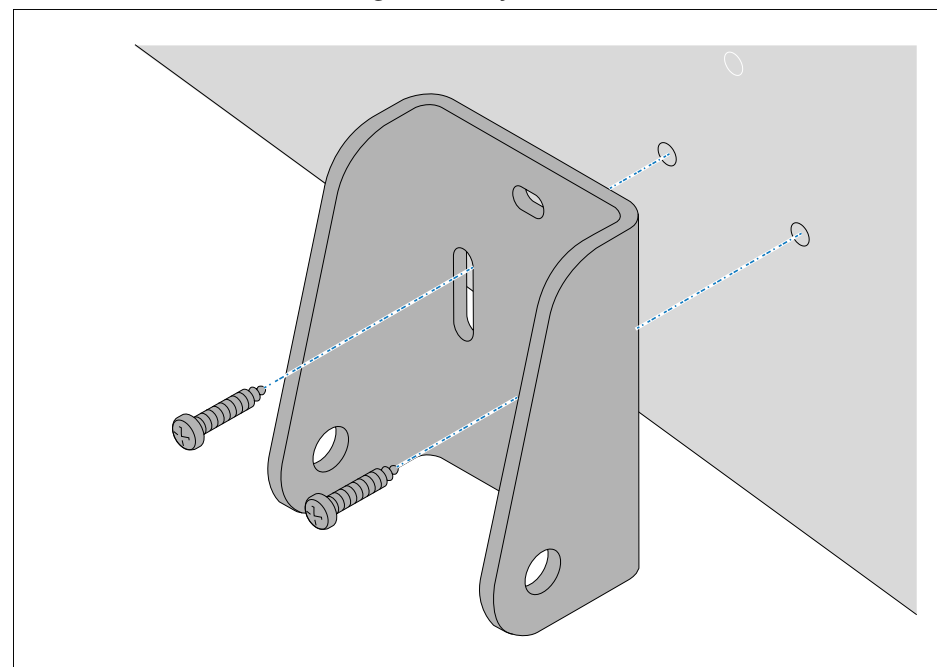

#### **Note:**

The third screw is not used until the transducer has been successfully tested.

## 5.3 Mounting the transducer

The transducer is mounted to the mounting bracket using the supplied nut and bolt.

### Important:

- Only perform the installation with your vessel out of the water.
- Do NOT lift or suspend the transducer using its cable.
- Do NOT overtighten the bolt. Overtightening may cause damage to the transducer.

### Note:

The screw located on top of the transducer is used when connecting the transducer to a mounting adaptor such as the Step mount bracket (A80479). You do not need to adjust this screw for transom mount installations.

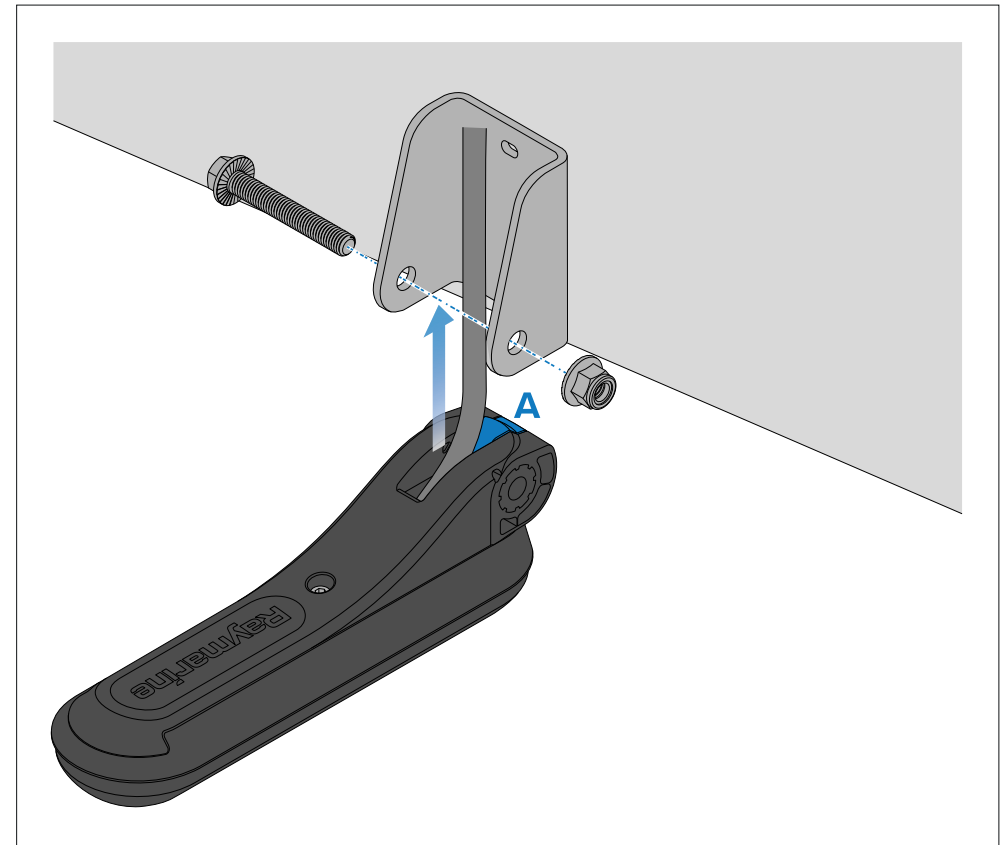

1. Ensure that the plastic chock (marked 'A' in the illustration) is positioned in front of the transducer cable. If it is not, push the chock into the correct position, aligning the hole in the chock with the holes in the transducer.
2. Position the transducer between the arms of the mounting bracket.
3. Align the hole in the transducer with the holes in the mounting bracket.
4. Slide the mounting bolt through the holes.
5. Screw the flanged nylock nut onto the end of the mounting bolt.
6. Tighten the nut onto the mounting bolt, using 2 x 14 mm wrenches or adjustable wrenches, until the transducer is secure, but can still be adjusted (tilted) by hand.

- Tilt the transducer so that the bottom face of the transducer will be parallel with the waterline and tighten the nut and bolt until the transducer is held firmly in place.

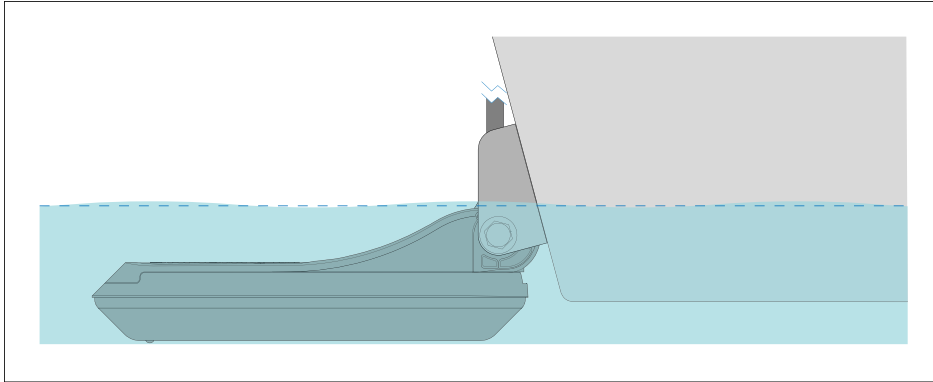

## 5.4 Attaching the connector locking collar

The supplied cable is provided with a separate locking collar assembly, ensuring that the cable connection is secure.

This procedure describes how to attach the locking collar to the cable connector. The locking collar parts are supplied in a separate bag, in the package with your product.

### Important:

Ensure that you route the cable all the way to its destination **before** attaching the locking collar.

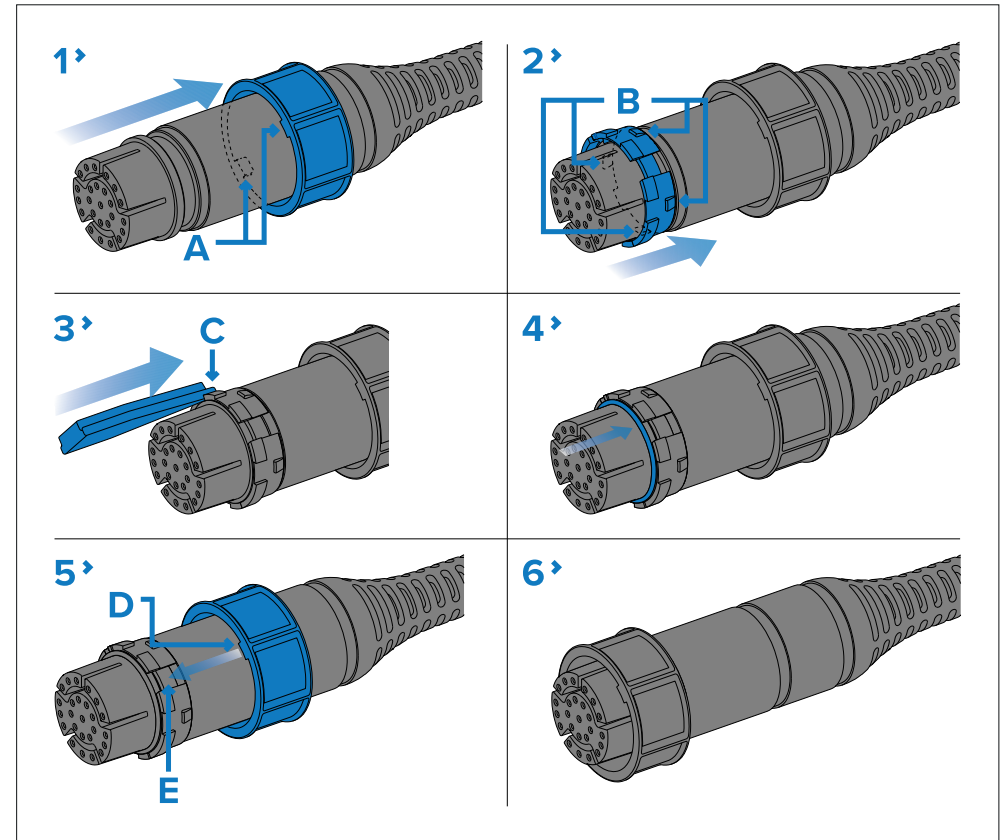

- Slide the locking collar over the end of the connector, then push it towards the cable-end of the connector. Ensure that the lugs on the locking collar (labelled 'A' in the illustration), are closest to the plug-end of the connector.
- Slide the split-ring over the end of the connector, then push it towards the cable-end of the connector. Ensure that the tabs on the split-ring (labelled 'B' in the illustration), are closest to the cable-end of the connector.

*The split-ring slides easily for approximately 1 cm (0.39 in) onto the connector, before butting up against the connector moulding.*

- Carefully insert the pointed end of the supplied tool into the split-ring's gap (labelled 'C' in the illustration). Use the tool to gently lever the split ring over the moulding on the connector until it snaps into position



approximately 0.5 cm further back towards the cable-end of the connector.

*Always use the supplied tool when attaching the split ring. The split ring may become overstretched and break if you try to attach it without using the tool. A spare split ring is supplied with the locking collar assembly, in case of breakage.*

- Slide the O-ring (arrowed) over the end of the connector, and ensure that it is seated squarely against the connector moulding, adjacent to the split-ring.
- Slide the locking collar towards the plug-end of the connector, rotating the collar as necessary to ensure that the lugs on the locking collar (labelled 'D' in the illustration) pass through the channels (labelled 'E') in the split-ring.

*The locking collar slides easily towards the plug-end of the connector, before butting up against the split-ring moulding.*

- Grasp the body of the connector with one hand, then with the other hand, pull the locking collar firmly towards the plug-end of the connector.

*As you pull the locking collar, it clicks into place over the split-ring. The locking collar stays in position on the connector, but rotates freely.*

## 5.5 Making connections

Follow the steps below to connect the cable(s) to your product.

- Ensure that the vessel's power supply is switched off.
- Ensure that the device being connected to the unit has been installed in accordance with the installation instructions supplied with that device.
- Ensuring correct orientation, push the cable connector fully onto the corresponding connector on the unit.
- Turn the locking collar clockwise to secure the cable.

### RealVision™ 3D transducer extension cable

For best performance, cable runs should be kept to a minimum. However, for some installations it may be necessary to extend the transducer cable.

- RealVision™ transducer extension cable 3 m (9.8 ft) (part number A80475)

- RealVision™ transducer extension cable 5 m (16.4 ft) (part number A80476)
- RealVision™ transducer extension cable 8 m (26.2 ft) (part number A80477)

## 5.6 Mounting the escutcheon plate

Your transducer is supplied with an escutcheon plate.

If you have chosen to route the transducer cable through the transom or through a bulkhead, you can use the supplied escutcheon plate to cover the hole required to accommodate the cable. The plate is designed to fit over a hole up to 25 mm (1 inch) in diameter.

After you have threaded the transducer cable through the hole in the transom or bulkhead, attach the escutcheon plate as shown, taking care that the cable is not trapped between the escutcheon plate and the mounting surface.

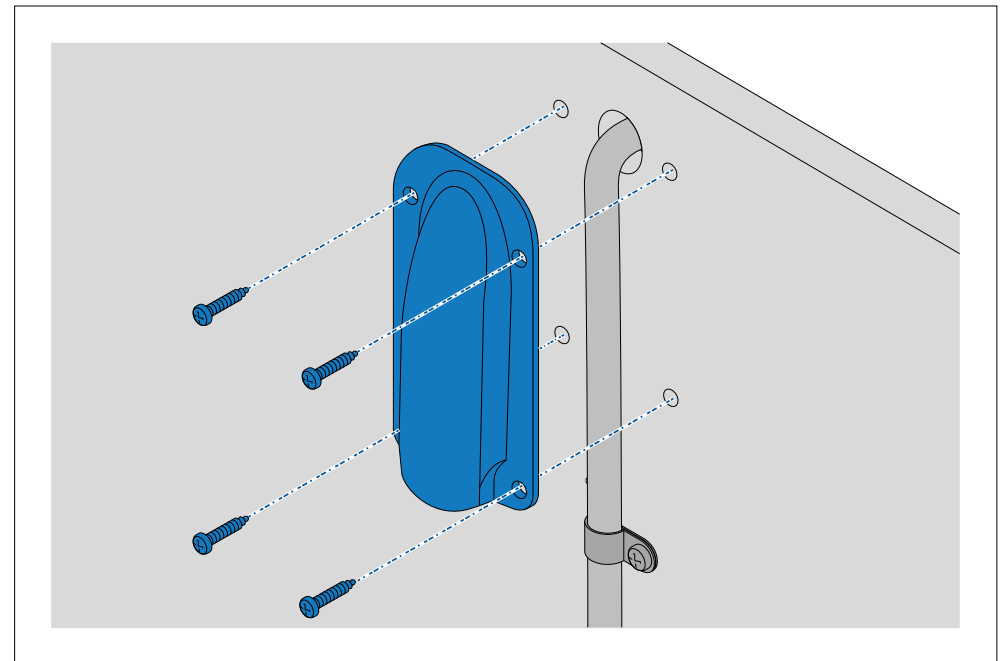

### Note:

To avoid possible damage to the transducer cable, use a file to round-off the edges of the hole that the cable passes through.

## 5.7 Testing and adjusting the transducer

After the initial installation has been carried out, the transducer should be tested and — if required — adjusted prior to finalizing the installation.

The testing should be carried out with your vessel in the water, with a depth greater than 0.7 m (2.3 ft) but less than the maximum depth range of the transducer / sonar channel.

### Note:

- It may not always be possible to obtain depth readings at higher speeds, due to air bubbles passing under the transducer.
- It may be necessary to make several adjustments to the transducer before obtaining optimum performance.
- If the transducer requires repositioning, ensure all old holes are filled with marine grade sealant.

1. Open the Fishfinder / Sonar app on your MFD, and select the [SONAR] option from the menu.  
After a few seconds, the sea bottom should be visible onscreen, and a depth reading displayed.
2. Start moving your vessel at a low speed, ensuring you have a depth reading and a clear image is displayed.
3. Gradually increase the vessel speed whilst checking the sonar image. If the image becomes poor or the bottom is missing at lower speeds, then the transducer needs to be adjusted.
4. Angle and height adjustments should be made in small increments and re-tested each time until you obtain optimum performance.
  - i. Loosen the mounting bolt to adjust the transducer angle.

### Angle adjustment

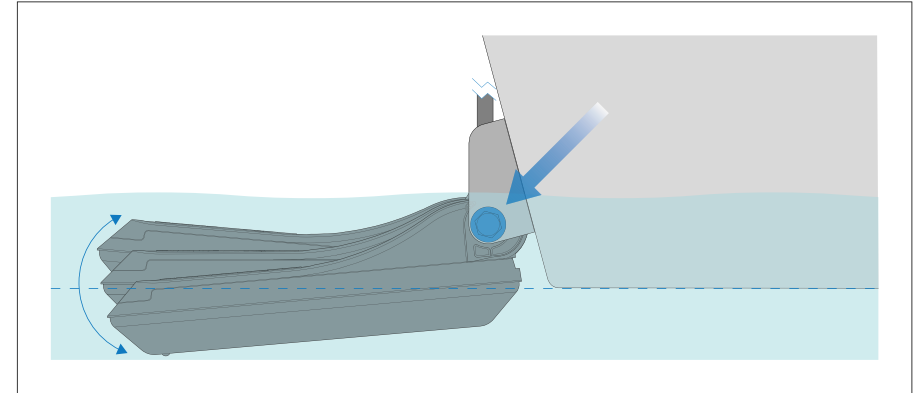

- ii. Loosen the 2 mounting bracket screws to adjust the transducer height.

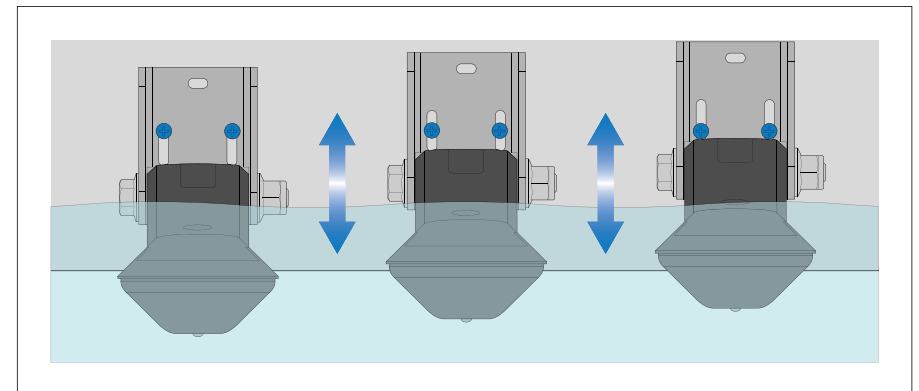

5. Re-tighten the mounting bolt and mounting screws before re-testing.

## 5.8 Finalizing the transducer mounting

After making any necessary adjustments to achieve optimum performance for your vessel, the transducer installation must be finalized by locking the transducer's position.

### Note:

After you apply marine grade sealant, always allow time for the sealant to fully cure before returning your vessel to the water.

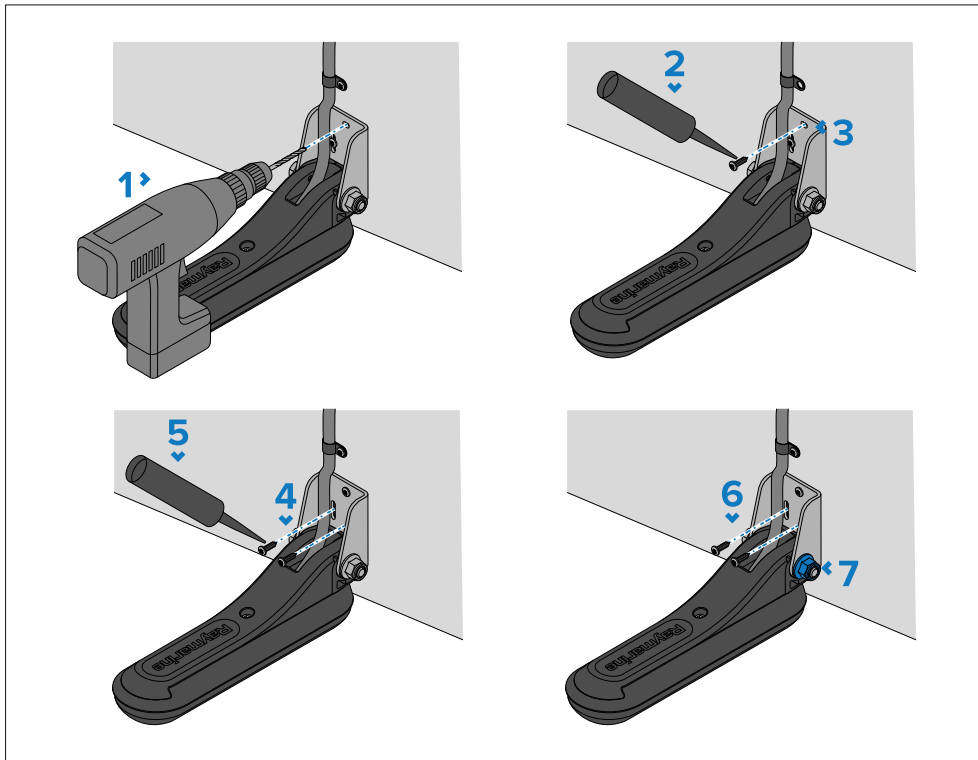

1. Drill the hole for the final locking screw, taking care not to damage the mounting bracket.
2. Apply marine grade sealant to the screw thread.
3. Insert and tighten the third 'locking' screw.
4. Carefully remove the 2 x screws in the adjustment slots.
5. Apply marine grade sealant to the screw threads.

6. Re-insert and tighten the screws.
7. Fully tighten the nut and bolt.

*Do not exceed a torque of 35 N·m (25.8 lbf·ft). The transducer should not be easily moveable by hand, and should remain in its normal operating position when your vessel is underway.*

# CHAPTER 6: SYSTEM CHECKS AND TROUBLESHOOTING

## CHAPTER CONTENTS

- [6.1 RealVision™ AHRS calibration — page 29](#)
- [6.2 Troubleshooting — page 29](#)

## 6.1 RealVision™ AHRS calibration

RealVision™ transducers include a built-in AHRS (Attitude and Heading Reference Sensor), which measures the motion of your vessel to assist in the rendering of sonar images. After installation all RealVision™ transducers require calibration.

An uncalibrated transducer can produce an offset to the front edge of the render of the bottom in the sonar image, as illustrated below.

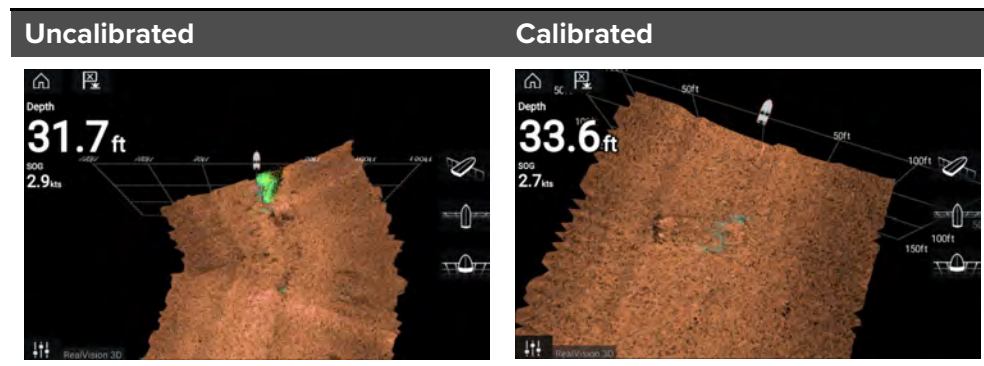

Calibration is an automatic process and starts after your vessel has turned approximately 100° at a speed of between 3 –15 knots. Calibration requires no user input, however at least a 270° turn is required before the calibration process can determine the local deviation and apply a relevant offset.

The time it takes to complete the calibration process will vary according to the characteristics of the vessel, the installation environment of the transducer, and the levels of magnetic interference at the time of conducting the process. Sources of significant magnetic interference may increase the time required to complete the calibration process. Certain areas with substantial magnetic deviation may require extra circles or “figure of 8” manoeuvres to be performed. Examples of such sources of magnetic interference include:

- Vessel engines
- Vessel alternators
- Marine pontoons
- Metal-hulled vessels
- Underwater cables

### Note:

In some circumstances, it is beneficial to disable Realvision AHRS if local sources of magnetic interference are distorting the sonar image. Realvision AHRS can be disabled from [Settings].

[Menu > Settings > Sounder > AHRS stabilization]

### Note:

The Calibration process will require repeating after a [Sonar reset] or MFD [Factory reset].

## 6.2 Troubleshooting

The troubleshooting section provides possible causes and the corrective action required for common problems that are associated with the installation and operation of your product.

Before packing and shipping, all Raymarine® products are subjected to comprehensive testing and quality assurance programs. If you do experience problems with your product, this section will help you to diagnose and correct problems to restore normal operation.

If after referring to this section you are still having problems with your product, please refer to the *Technical support* section of this manual for useful links and Raymarine® Product Support contact details.

### Operation instructions

For detailed operation instructions for your product, refer to the documentation that accompanies your display.

All product documentation is available to download from the Raymarine website: [www.raymarine.com/manuals](http://www.raymarine.com/manuals).

## Sonar troubleshooting

### Scrolling image is not being displayed

Possible causes	Possible solutions
Sonar disabled	Enable [Ping] from the Fishfinder app's sounder tab: [Menu > Settings > Sounder > Ping enable].
Incorrect transducer selected	Check that the correct transducer is selected in the Fishfinder app's Transducer tab: [Menu > Settings > Transducer].
Damaged cables	<ol style="list-style-type: none"> <li>1. Check that the transducer cable connector is fully inserted and locked in position.</li> <li>2. Check the power supply cable and connectors for signs of damage or corrosion, replace if necessary.</li> <li>3. With the unit turned on, try flexing the cable near to the display connector to see if this causes the unit to re-boot/lose power, replace if necessary.</li> <li>4. Check the vessel's battery voltage, the condition of the battery terminals and power supply cables, ensuring connections are secure, clean and free from corrosion, replace if necessary.</li> <li>5. With the product under load, using a multi-meter, check for high voltage drop across all connectors/fuses etc (this can cause the Fishfinder applications to stop scrolling or the unit to reset/turn off), replace if necessary.</li> </ol>
Damaged or fouled transducer	<p>Check transducer condition, ensuring it is not damaged and is free from debris/fouling. If necessary, clean or replace your transducer.</p> <p>After cleaning or replacement coat the transducer using a water-based anti-fouling paint.</p>
Wrong transducer fitted	Check product and transducer documentation and ensure that the transducer is compatible with your system.

Possible causes	Possible solutions
External sonar module: network connection problem.	Check that the unit is correctly connected to your display or network switch. Check all connections to ensure that they are secure, clean and free from corrosion, replace if necessary.
External sonar module: software mismatch between equipment may prevent communication.	Ensure all Raymarine® products contain the latest available software, check the Raymarine® website: <a href="http://www.raymarine.com/software">www.raymarine.com/software</a> for software compatibility.

### No depth reading / lost bottom lock

Possible causes	Possible solutions
Transducer location	Check that the transducer has been installed in accordance with the instructions provided with the transducer.
Transducer angle	If the transducer angle is too great the beam can miss the bottom, adjust transducer angle and recheck.
Transducer kicked-up	If the transducer has a kick-up mechanism, check that it has not kicked up due to hitting an object.
Power source insufficient	With the product under load, using a multi-meter, check the power supply voltage as close to the unit as possible to establish actual voltage when the current is flowing. (Check your product's Technical specification for power supply requirements.)
Damaged or fouled transducer	<p>Check transducer condition, ensuring it is not damaged and is free from debris/fouling. If necessary, clean or replace your transducer.</p> <p>After cleaning or replacement coat the transducer using a water-based anti-fouling paint.</p>

Possible causes	Possible solutions
Damaged cables	<ol style="list-style-type: none"> <li>1. Check the unit's connector for broken or bent pins.</li> <li>2. Check that the cable connector is fully inserted into the unit and that the locking collar is in the locked position.</li> <li>3. Check the cable and connectors for signs of damage or corrosion, replace if necessary.</li> <li>4. With the unit turned on, try flexing the power cable near to the display connector to see if this causes the unit to re-boot/lose power, replace if necessary.</li> <li>5. Check the vessel's battery voltage, the condition of the battery terminals and power supply cables, ensuring connections are secure, clean and free from corrosion, replace if necessary.</li> <li>6. With the product under load, using a multi-meter, check for high voltage drop across all connectors/fuses etc (this can cause the Fishfinder applications to stop scrolling or the unit to reset/turn off), replace if necessary.</li> </ol>
Vessel speed too high	Slow vessel speed and recheck.
Bottom too shallow or too deep	The bottom depth may be outside of the transducers depth range, move vessel to shallower or deeper waters as relevant and recheck.
Ping depth limit set	<p>If using a transducer with greater than 600 W power, check if the <i>[Ping depth limit]</i> has been enabled: <i>[Menu &gt; Settings &gt; Transducer &gt; Ping depth limit]</i>.</p> <p>If you are in water deeper than the specified <i>[Ping depth limit]</i> then the transducer may not provide depth readings.</p> <p>Disable or adjust setting and retry.</p>

## Poor / problematic image

Possible causes	Possible solutions
Targets will appear differently if your vessel is stationary (e.g.: fish will appear on the display as straight lines).	Increase vessel speed.
Scrolling paused or speed set too low	Unpause or increase sonar scrolling speed.
Sensitivity settings may be inappropriate for present conditions.	Check and adjust sensitivity settings or perform a Sonar reset.
Damaged cables	<ol style="list-style-type: none"> <li>1. Check the unit's connector for broken or bent pins.</li> <li>2. Check that the cable connector is fully inserted into the unit and that the locking collar is in the locked position.</li> <li>3. Check the cable and connectors for signs of damage or corrosion, replace if necessary.</li> <li>4. With the unit turned on, try flexing the power cable near to the display connector to see if this causes the unit to re-boot/lose power, replace if necessary.</li> <li>5. Check the vessel's battery voltage, the condition of the battery terminals and power supply cables, ensuring connections are secure, clean and free from corrosion, replace if necessary.</li> <li>6. With the product under load, using a multi-meter, check for high voltage drop across all connectors/fuses etc (this can cause the Fishfinder applications to stop scrolling or the unit to reset/turn off), replace if necessary.</li> </ol>

Possible causes	Possible solutions
Transducer location	<ul style="list-style-type: none"> <li>Check that the transducer has been installed in accordance with the instructions provided with the transducer.</li> <li>If a transom mount transducer is mounted too high on the transom it may be lifting out of the water, check that the transducer face is fully submerged when planing and turning.</li> </ul>
Transducer kicked-up	If the transducer has a kick-up mechanism, check that it has not kicked up due to hitting an object.
Damaged or fouled transducer	<p>Check transducer condition, ensuring it is not damaged and is free from debris/fouling. If necessary, clean or replace your transducer.</p> <p>After cleaning or replacement coat the transducer using a water-based anti-fouling paint.</p>
Damaged transducer cable	Check that the transducer cable and connection is free from damage and that the connections are secure and free from corrosion.
Turbulence around the transducer at higher speeds may affect transducer performance	Slow vessel speed and recheck.
Interference from another transducer	<ol style="list-style-type: none"> <li>Turn off the transducer causing the interference.</li> <li>Reposition the transducers so they are farther apart.</li> </ol>
Unit power supply fault	Check the voltage from the power supply, if this is too low it can affect the transmitting power of the unit.

2. Select *[Set-up]*.
3. Select *[Sounder Set-up]*.
4. Select *[Sonar Reset]*.
5. Select *[Yes]* to confirm or *[No]* to abort the operation, as appropriate.

The unit will now be reset to factory default settings.

## Resetting the sonar module

You can use the reset function on a compatible Raymarine multifunction display to restore the sonar module to its factory default settings.

In the fishfinder application:

1. Select *[Menu]*.



# CHAPTER 7: MAINTENANCE

## CHAPTER CONTENTS

- 7.1 Routine checks — page 34
- 7.2 Unit cleaning instructions — page 34

## 7.1 Routine checks

The following periodic checks should be made:

- Examine cables for signs of damage, such as chafing, cuts or nicks.
- Check that the cable connectors are firmly attached and that their locking mechanisms are properly engaged.

**Note:**

Cable checks should be carried out with the power supply switched off.



**Warning: High voltage**

This product contains high voltage. Adjustments require specialized service procedures and tools only available to qualified service technicians. There are no user serviceable parts or adjustments. The operator should never remove the cover or attempt to service the product.

## 7.2 Unit cleaning instructions

The unit does not require regular cleaning. However, if you find it necessary to clean the unit, please follow the steps below:

1. Ensure power is switched off.
2. Wipe unit clean with a damp cloth.
3. If necessary, use a mild detergent solution to remove grease marks.

## Transducer cleaning

You must clean your transducer regularly to remove organic growth. Organic growth can build up quickly on the bottom face of your transducer; this can impact transducer performance in a matter of weeks.

**Important:**

- When cleaning growth from an anti-fouled transducer, take care not to let paint dust and other debris enter the water, as this can have an impact on aquatic life.
- Take care not to scratch the surface of the transducer as this can impact transducer performance.
- Do NOT use harsh cleaning solvents such as acetone as this will damage the transducer.

Follow the guidance below to clean growth from your transducer:

- Use a soft cloth and a mild household cleaning detergent to clean mild growth build up.
- Use a scouring pad, such as a green Scotch Brite™ pad and a mild household cleaning detergent to clean moderate growth build up.
- You may need to use a fine grade wet and dry paper and a mild household cleaning detergent to clean severe build up.

# CHAPTER 8: TECHNICAL SUPPORT

## CHAPTER CONTENTS

- [8.1 Raymarine product support and servicing — page 36](#)
- [8.2 Learning resources — page 37](#)

## 8.1 Raymarine product support and servicing

Raymarine provides a comprehensive product support service, as well as warranty, service, and repairs. You can access these services through the Raymarine website, telephone, and e-mail.

### Product information

If you need to request service or support, please have the following information to hand:

- Product name.
- Product identity.
- Serial number.
- Software application version.
- System diagrams.

You can obtain this product information using diagnostic pages of the connected display.

### Servicing and warranty

Raymarine offers dedicated service departments for warranty, service, and repairs.

Don't forget to visit the Raymarine website to register your product for extended warranty benefits: <https://www.raymarine.com/en-us/support/product-registration>

#### **United Kingdom (UK), EMEA, and Asia Pacific:**

- E-Mail: [emea.service@raymarine.com](mailto:emea.service@raymarine.com)
- Tel: +44 (0)1329 246 932

#### **United States (US):**

- E-Mail: [rm-usrepair@flir.com](mailto:rm-usrepair@flir.com)
- Tel: +1 (603) 324 7900

### Web support

Please visit the "Support" area of the Raymarine website for:

- **Manuals and Documents** — <http://www.raymarine.com/manuals>
- **Technical support forum** — <https://raymarine.custhelp.com/app/home>
- **Software updates** — <http://www.raymarine.com/software>

### Worldwide support

#### **United Kingdom (UK), EMEA, and Asia Pacific:**

- Help desk: <https://raymarine.custhelp.com/app/home>
- Tel: +44 (0)1329 246 777

#### **United States (US):**

- Help desk: <https://raymarine.custhelp.com/app/home>
- Tel: +1 (603) 324 7900 (Toll-free: +800 539 5539)

#### **Australia and New Zealand (Raymarine subsidiary):**

- E-Mail: [aus.support@raymarine.com](mailto:aus.support@raymarine.com)
- Tel: +61 2 8977 0300

#### **France (Raymarine subsidiary):**

- E-Mail: [support.fr@raymarine.com](mailto:support.fr@raymarine.com)
- Tel: +33 (0)1 46 49 72 30

#### **Germany (Raymarine subsidiary):**

- E-Mail: [support.de@raymarine.com](mailto:support.de@raymarine.com)
- Tel: +49 40 237 808 0

#### **Italy (Raymarine subsidiary):**

- E-Mail: [support.it@raymarine.com](mailto:support.it@raymarine.com)
- Tel: +39 02 9945 1001

#### **Spain (Authorized Raymarine distributor):**

- E-Mail: [sat@azimut.es](mailto:sat@azimut.es)
- Tel: +34 96 2965 102

#### **Netherlands (Raymarine subsidiary):**

- E-Mail: [support.nl@raymarine.com](mailto:support.nl@raymarine.com)
- Tel: +31 (0)26 3614 905

#### **Sweden (Raymarine subsidiary):**

- E-Mail: [support.se@raymarine.com](mailto:support.se@raymarine.com)
- Tel: +46 (0)317 633 670

#### **Finland (Raymarine subsidiary):**

- E-Mail: [support.fi@raymarine.com](mailto:support.fi@raymarine.com)
- Tel: +358 (0)207 619 937

#### **Norway (Raymarine subsidiary):**

- E-Mail: [support.no@raymarine.com](mailto:support.no@raymarine.com)

- Tel: +47 692 64 600

**Denmark (Raymarine subsidiary):**

- E-Mail: [support.dk@raymarine.com](mailto:support.dk@raymarine.com)
- Tel: +45 437 164 64

**Russia (Authorized Raymarine distributor):**

- E-Mail: [info@mikstmarine.ru](mailto:info@mikstmarine.ru)
- Tel: +7 495 788 0508

**Viewing product information**

Use the *[Settings]* menu to view hardware and software information about your display, and connected products.

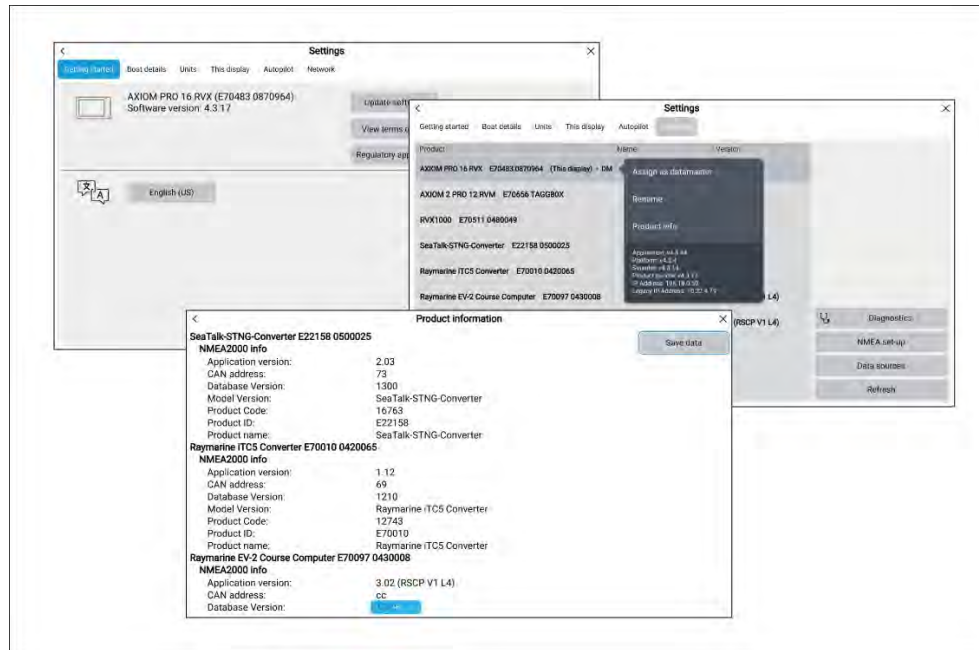

1. Select *[Settings]*, from the Homescreen.  
The *[Getting started]* menu contains hardware and software information for your display.
2. You can view further information about your display, or view information about products networked using SeaTalkhs® and SeaTalkng® / NMEA 2000, by selecting the *[Network]* tab, then:

- i. to display detailed software information and your display's network IP address, select your display from the list.
- ii. to display detailed diagnostics information for all products, select *[Product info]* from the *[Diagnostics]* pop over menu.

**8.2 Learning resources**

Raymarine has produced a range of learning resources to help you get the most out of your products.

**Video tutorials**

*Raymarine official channel on YouTube*

- <http://www.youtube.com/user/RaymarineInc>

**Training courses**

Raymarine regularly runs a range of in-depth training courses to help you make the most of your products. Visit the Training section of the Raymarine website for more information:

- <http://www.raymarine.co.uk/view/?id=2372>

**Technical support forum**

You can use the Technical support forum to ask a technical question about a Raymarine product or to find out how other customers are using their Raymarine equipment. The resource is regularly updated with contributions from Raymarine customers and staff:

- <https://raymarine.custhelp.com/app/home>

# CHAPTER 9: TECHNICAL SPECIFICATION

## CHAPTER CONTENTS

- [9.1 Technical specification — page 39](#)

## 9.1 Technical specification

### Physical specification

Specification	
<b>Dimensions (including bracket):</b>	<ul style="list-style-type: none"><li>• Length: 256.6 mm (10.10 in)</li><li>• Height: 120.5 mm (4.74 in)</li></ul>
<b>Cable length:</b>	8 m (26.2 ft)
<b>Weight (including bracket):</b>	0.647 kg (1.42 lb)

### Environmental specification

Specification	
<b>Operating temperature range:</b>	−2°C (28.4°F) to + 55°C (131°F)
<b>Storage temperature range:</b>	−20°C (23°F) to + 70°C (158°F)
<b>Waterproof rating:</b>	<ul style="list-style-type: none"><li>• IPx6 (surfaces exterior to hull, only)</li><li>• IPx7</li><li>• IPx8</li></ul>

### RealVision™ 3D sonar specification

The following specification only applies to RealVision™ 3D products.

Specification	
<b>Sonar channels:</b> <i>(Output power / Responsive Frequency Range)</i>	<ul style="list-style-type: none"><li>• <b>RealVision™ 3D</b> (70 W / 350 kHz ± 5%)</li><li>• <b>SideVision™</b> (70 W / 350 kHz ± 5%)</li><li>• <b>DownVision™</b> (35 W / 350 kHz ± 5%)</li><li>• <b>Conical CHIRP: High</b> (100 W / 200 kHz ± 5%)</li></ul>
<b>Sensors:</b>	<ul style="list-style-type: none"><li>• Temperature sensor</li><li>• AHRS (Attitude and Heading Reference System) sensor</li></ul>

### Sonar range

The sonar range is the effective depth or distance that the transducer can operate to, **in optimum weather conditions**.

The following ranges apply to RealVision™ 3D sonar channels:

Note:	
The listed sonar channel ranges are indicative only, and may differ depending on the transducer in use, the installation, and the prevailing water conditions.	
Sonar channel	Range
<b>CHIRP sonar:</b>	0.6 m (2 ft) to 274 m (900 ft)
<b>DownVision™:</b>	0.6 m (2 ft) to 183 m (600 ft)
<b>SideVision™:</b>	0.6 m (2 ft) to 91 m (300 ft)
<b>RealVision™ 3D:</b>	0.6 m (2 ft) to 91 m (300 ft)

### Conformance specification

Specification	
<b>Standards:</b>	<ul style="list-style-type: none"><li>• EN 60945:2002</li><li>• IEC 28846:1993</li><li>• EMC Directive 2014/30/EU</li><li>• Australia and New Zealand: C-Tick, Compliance Level 2</li></ul>

# CHAPTER 10: SPARES AND ACCESSORIES

## CHAPTER CONTENTS

- [10.1 Accessories — page 41](#)



## 10.1 Accessories

### Extension cables and adapters

- **A80515** — RealVision™ transducer right-angled adapter cable 400 mm (15.7 in.).
- **A80475** — RealVision™ transducer extension cable 3 m (11.8 ft.).
- **A80476** — RealVision™ transducer extension cable 5 m (19.7 ft.).
- **A80477** — RealVision™ transducer extension cable 8 m (31.5 ft.).

### Mounting accessories

- **A80479** — RealVision™ transducer step mount.
- **A80480** — RealVision™ transducer jack plate mount
- **A80482** — RealVision™ transducer jack plate spacer kit



## Index

### A

Accessories ..... 41

### B

Bracket mounting ..... 22

### C

Cable  
  Protection ..... 20  
  Strain relief ..... 20  
Cable extension ..... 20, 25  
Cable routing ..... 20  
Calibration  
  RealVision™ ..... 29  
Cleaning ..... 34  
Cleaning the transducer ..... 34  
Compatible products ..... 15  
Connections ..... 25  
  General cabling guidance ..... 20  
Contact details ..... 36

### D

Diagnostics ..... 37  
Dimensions ..... 18  
Documentation  
  Installation instructions ..... 12  
  Mounting template ..... 12  
  Operation instructions ..... 12, 29

### E

Escutcheon plate ..... 25

### F

Finalizing mounting ..... 27

### I

Installation  
  Cable bend radius ..... 18  
  Cable length ..... 18  
  Checklist ..... 14  
  Schematic diagram ..... 14  
  Testing ..... 22, 26  
  Tools ..... 16  
  Transducer ..... 23  
IP address ..... 37

### L

LightHouse 3 ..... 12  
LightHouse 4 ..... 12  
Location requirements  
  General ..... 16

### M

Maintenance ..... 7, 34  
Mounting the transducer ..... 23

### O

Operation instructions ..... 12, 29  
  LightHouse ..... 12

### P

Parts supplied ..... 14  
Product information ..... 37  
Product overview ..... 11  
Product recycling (WEEE) ..... 8  
Product support ..... 36

### R

RealVision™ 3D transducer ..... 11  
Routine checks ..... 34

## S

Service Center.....	36
Servicing.....	7
Sonar range.....	39
Support forum .....	37

## T

Technical specification.....	38–39
Environmental.....	39
Technical Specification	
Conformance .....	39
Physical.....	39
RealVision 3D Sonar .....	39
Technical support.....	36–37
Temperature range .....	39
Tools required .....	16
Training courses.....	37
Transducer mounting .....	22
Troubleshooting .....	29
Sonar .....	30

## W

Warranty .....	8, 36
WEEE Directive.....	8





**Raymarine (UK / EU)**

Marine House, Cartwright Drive,  
Fareham, Hampshire.  
PO15 5RJ.  
United Kingdom.

Tel: (+44) (0)1329 246 700

[www.raymarine.co.uk](http://www.raymarine.co.uk)

**Raymarine (US)**

110 Lowell Road,  
Hudson, NH 03051.  
United States of America.

Tel: (+1) 603-324-7900

[www.raymarine.com](http://www.raymarine.com)



**Raymarine®**