



# CHARGEMASTER PLUS

12/75-3, 12/100-3, 24/40-3, 24/60-3

FULLY AUTOMATIC BATTERY CHARGER



USER AND INSTALLATION MANUAL

10000011898/13

## TABLE OF CONTENTS

<b>1 GENERAL INFORMATION .....</b>	<b>3</b>
1.1 Use of this manual.....	3
1.2 Liability .....	3
1.3 Warranty.....	3
1.4 Disclaimer.....	3
1.5 Identification label.....	3
1.6 Correct disposal of this product.....	3
<b>2 SAFETY INSTRUCTIONS .....</b>	<b>4</b>
2.1 General.....	4
2.2 Explosive gases .....	4
2.3 Personal precautions.....	4
2.4 Warnings regarding the use of batteries.....	5
2.5 Charger location .....	5
2.6 DC connection precautions .....	5
2.7 When battery is installed in vehicle .....	5
2.8 When battery is outside vehicle.....	5
2.9 Preparing to charge.....	5
2.10 Grounding instructions.....	6
2.11 Warning regarding life support applications.....	6
<b>3 INSTALLATION.....</b>	<b>7</b>
3.1 Unpacking .....	7
3.2 Environment .....	7
3.3 Wiring .....	7
3.4 Batteries .....	8
3.5 Things you need.....	8
3.6 Overview connection compartment .....	9
3.7 Connection example.....	10
3.8 Installation step-by-step.....	11
3.9 Commissioning after installation.....	12
3.10 MasterBus (optional) .....	13
3.11 Decommissioning .....	13
3.12 Storage and transportation.....	13
3.13 Re-installation.....	13
<b>4 SETTINGS .....</b>	<b>14</b>
4.1 DIP switch settings .....	14
4.2 MasterBus functions.....	14
<b>5 OPERATING INSTRUCTIONS .....</b>	<b>19</b>
5.1 Introduction.....	19
5.2 Switching on / stand-by .....	19
5.3 Status display .....	19
5.4 The 3-step+ charge process.....	21
5.5 Smart terminal - Output 3 .....	22
5.6 Maintenance.....	23
5.7 Failures.....	23
5.8 History .....	23
<b>6 TROUBLE SHOOTING.....</b>	<b>24</b>
<b>7 TECHNICAL DATA .....</b>	<b>25</b>
7.1 Specifications 12V models .....	25
7.2 Specifications 24V models .....	26
7.3 Dimensions.....	27
7.4 3-Step+ charging characteristics of flooded batteries.....	27

## 1 GENERAL INFORMATION

### 1.1 Use of this manual

This manual serves as a guideline for the safe and effective operation and maintenance of the ChargeMaster Plus 12/75-3, 12/100-3, 24/40-3 or 24/60-3. This manual is only valid for models with apparatus version “D” (see section 1.5). These models are further mentioned as “ChargeMaster Plus”.

### 1.2 Liability

Mastervolt can accept no liability for:

- Consequential damage resulting from the use of the ChargeMaster Plus.
- Possible errors in the included manual and the consequences of these.
- Use that is inconsistent with the purpose of the product.

### 1.3 Warranty

Mastervolt assures the product warranty of the ChargeMaster Plus during two years after purchase, on the condition that the product is installed and used according to the instructions in this manual.

Installation or use not according to these instructions may result in under performance, damage or failure of the product and may void this warranty. The warranty is limited to the cost of repair and/or replacement of the product. Costs of labor or shipping are not covered by this warranty.

### 1.4 Disclaimer

Our products are subject to continual development and improvement. Therefore, additions or modifications to the products may cause changes to the technical data and functional specifications. No rights can be derived from this document. Please consult our most current Terms & Conditions of Sale.

### 1.5 Identification label

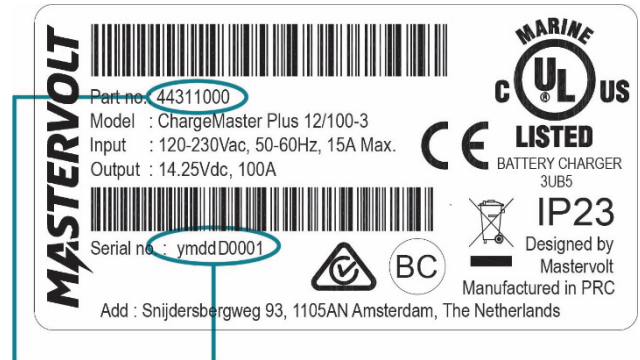

Part number      Serial number with device version “D”

Figure 1: Identification label

The identification label is located at the right-hand side of the ChargeMaster Plus. Important technical information required for service, maintenance & secondary delivery of parts can be derived from the identification label.



#### CAUTION!

Never remove the identification label.

### 1.6 Correct disposal of this product



This product is designed and manufactured with high quality materials and components, which can be recycled and reused. When this crossed-out wheeled bin symbol is attached to a product, it means the product is covered by the European Directive 2012/19/EU.

Please be informed about the local separate collection system for electrical and electronic products.

Please act according to your local rules and do not dispose of your old products with your normal household waste. The correct disposal of your old product will help prevent potential negative consequences to the environment and human health.

## 2 SAFETY INSTRUCTIONS

### IMPORTANT SAFETY INSTRUCTIONS SAVE THESE INSTRUCTIONS

Read the entire manual before using the ChargeMaster Plus. Keep this manual in a secure place.

This chapter describes important safety and operating instructions for use of a ChargeMaster Plus in residential, recreational vehicle (RV) and marine applications.

#### 2.1 General

- 1 The appliance is not to be used by children or persons with reduced physical, sensory or mental capabilities, or lack of experience and knowledge, unless they have been given supervision or instruction
- 2 To reduce the risk of electric shock – Do not expose the ChargeMaster Plus to rain, snow, spray, moisture, excessive pollution and condensing circumstances. To reduce risk of fire hazard, do not cover or obstruct the ventilation openings. Do not install the ChargeMaster Plus in a non-ventilated room, overheating may result.
- 3 Use of an attachment or spare part not recommended or sold by Mastervolt may result in a risk of fire, electric shock, or injury to persons.
- 4 The ChargeMaster Plus is designed to be permanently connected to an AC and DC electrical system. Installation of, and work on the ChargeMaster Plus, may be carried out only by qualified and trained personnel, consistent with the locally applicable standards and regulations.
- 5 Make sure that all wiring is properly installed, in good electrical condition, and correctly sized to match the AC ampere rating of the ChargeMaster Plus. Check the wiring on a regular base, at least once a year. Do not use the ChargeMaster Plus when the wiring is undersized or damaged.
- 6 Do not operate the ChargeMaster Plus if it has received a sharp blow, been dropped, or otherwise damaged in any way; take it to a qualified serviceman.
- 7 Except for the connection compartment, see chapter 3, the ChargeMaster Plus may not be opened or disassembled. There are no serviceable parts inside the cabinet. Take it to a qualified, authorized and trained serviceman when service or repair is required. Incorrect reassembly may result in a risk of electric shock or fire.
- 8 To reduce risk of electric shock, disconnect the ChargeMaster Plus from both AC and DC electrical system before attempting any maintenance or cleaning. Turning off controls will not reduce this risk. Be sure that third parties cannot reverse the measures taken.

- 9 The ChargeMaster Plus must be provided with an equipment-grounding conductor to the AC input ground terminal. Grounding and all other wiring must comply with local codes and ordinances.
- 10 Short circuiting or reversing polarity will lead to serious damage to batteries, ChargeMaster Plus, wiring as well as accessories. Fuses cannot prevent damage caused by reversed polarity and the warranty will be void.
- 11 In case of fire, you must use the fire extinguisher which is appropriate for electrical equipment.
- 12 If applied in a marine application in the United States, external connections to the ChargeMaster Plus shall comply with the United States Coast Guard Electrical Regulations (33CFR183, Sub part I).

#### 2.2 Explosive gases

- 1 WARNING – RISK OF EXPLOSIVE GASES. WORKING IN VICINITY OF A LEAD-ACID BATTERY IS DANGEROUS. BATTERIES GENERATE EXPLOSIVE GASES DURING NORMAL BATTERY OPERATION. FOR THIS REASON, IT IS OF UTMOST IMPORTANCE THAT EACH TIME BEFORE USING THE CHARGE MASTER PLUS, YOU READ THIS MANUAL AND FOLLOW THE INSTRUCTIONS EXACTLY.
- 2 To reduce risk of battery explosion, follow these instructions and those published by battery manufacturer and manufacturer of any equipment you intend to use in vicinity of the battery. Review cautionary marking on these products and on engine.

#### 2.3 Personal precautions

- 1 Consider having someone close enough by to come to your aid when you work near a lead-acid battery.
- 2 Have plenty of fresh water and soap nearby in case battery acid contacts skin, clothing, or eyes.
- 3 Wear eye and clothing protection. Avoid touching eyes while working near battery.
- 4 If battery acid contacts skin or clothing, wash immediately with soap and water. If acid enters eye, immediately flood eye with running cold water for at least 10 minutes and get medical attention immediately.
- 5 NEVER smoke or allow a spark or flame in vicinity of battery or engine.
- 6 Be extra cautious to reduce risk of dropping a metal tool onto battery. It might spark or short-circuit battery or other electrical part that may cause explosion.
- 7 Do not wear watches, bracelets, necklaces or other metal objects when working on batteries.

## 2.4 Warnings regarding the use of batteries

- 1 Only use ChargeMaster Plus for charging LEAD-ACID batteries and the supply of users attached to these batteries, in permanent systems. Do not use ChargeMaster Plus for charging dry-cell batteries that are commonly used with home appliances. These batteries may burst and cause injury to persons and damage to property.
- 2 NEVER charge non-rechargeable batteries.
- 3 NEVER charge a frozen battery.
- 4 Excessive battery discharge and/or high charging voltages can cause serious damage to batteries. Do not exceed the recommended limits of discharge level of your batteries.
- 5 If it is necessary to remove a battery, always remove grounded terminal from battery first. Make sure all accessories are off, so as not to cause an arc.
- 6 Be sure that the area around battery is well ventilated while battery is being charged. Refer to the recommendations of the battery manufacturer.
- 7 Batteries are heavy! It may become a projectile if it is involved in an accident! Ensure adequate and secure mounting and always use suitable handling equipment for transportation.

## 2.5 Charger location

- 1 Never place charger directly above battery being charged; gases from battery will corrode and damage charger.
- 2 Never allow battery acid to drip on charger when reading electrolyte specific gravity or filling battery.
- 3 Do not operate charger in a closed-in area or restrict ventilation in any way.
- 4 Do not set a battery on top of charger.

## 2.6 DC connection precautions

- 1 Connect and disconnect DC output clips only after setting any charger switches to “off” position and removing AC cord from electric outlet. Never allow clips to touch each other.
- 2 Attach clips to battery and chassis as indicated in section 2.7, steps 5 and 6, and 2.8 steps 2 through 4.

## 2.7 When battery is installed in vehicle

### A SPARK MAY CAUSE BATTERY EXPLOSION.

To reduce risk of a spark near battery:

- 1 Position AC and DC cords to reduce risk of damage by hood, door, or moving engine part.
- 2 Stay clear of fan blades, belts, pulleys, and other parts that can cause injury to persons.
- 3 Check polarity of battery posts. POSITIVE (POS, P, +) battery post usually has larger diameter than NEGATIVE (NEG, N, -) post.

- 4 Determine which post of battery is grounded (connected) to the chassis. If negative post is grounded to chassis (as in most vehicles), see (5). If positive post is grounded to the chassis, see (6).
- 5 For negative-grounded vehicle, connect POSITIVE (RED) clip from battery charger to POSITIVE (POS, P, +) ungrounded post of battery. Connect NEGATIVE (BLACK) clip to vehicle chassis or engine block away from battery. Do not connect clip to carburetor, fuel lines, or sheet-metal body parts. Connect to a heavy gage metal part of the frame or engine block.
- 6 For positive-grounded vehicle, connect NEGATIVE (BLACK) clip from battery charger to NEGATIVE (NEG, N, -) ungrounded post of battery. Connect POSITIVE (RED) clip to vehicle chassis or engine block away from battery. Do not connect clip to carburetor, fuel lines, or sheet-metal body parts. Connect to a heavy gage metal part of the frame or engine block.
- 7 When disconnecting charger, turn switches to off, disconnect AC cord, remove clip from vehicle chassis, and then remove clip from battery terminal.
- 8 See operating instructions for length of charge information.

## 2.8 When battery is outside vehicle

### A SPARK MAY CAUSE BATTERY EXPLOSION.

To reduce risk of a spark near battery:

- 1 Check polarity of battery posts. POSITIVE (POS, P, +) battery post usually has a larger diameter than NEGATIVE (NEG, N, -) post.
- 2 Attach at least a 24-inch-long 6-gauge (AWG) insulated battery cable to NEGATIVE (NEG, N, -) battery post.
- 3 Connect POSITIVE (RED) charger clip to POSITIVE (POS, P, +) post of battery.
- 4 Position yourself and free end of cable as far away from battery as possible – then connect NEGATIVE (BLACK) charger clip to free end of cable.
- 5 Do not face battery when making final connection.
- 6 When disconnecting charger, always do so in reverse sequence of connecting procedure and break first connection while as far away from battery as practical.

## 2.9 Preparing to charge

- 1 If necessary to remove battery from vehicle to charge, always remove grounded terminal from battery first. Make sure all accessories in the vehicle are off, so as not to cause an arc.
- 2 Be sure area around battery is well ventilated while battery is being charged.
- 3 Clean battery terminals. Be careful to keep corrosion from coming in contact with eyes.
- 4 Add distilled water in each cell until battery acid reaches level specified by battery manufacturer. Do

not overfill. For a battery without removable cell caps, such as valve regulated lead acid batteries, carefully follow manufacturer's recharging instructions.

- 5 Study all battery manufacturer's specific precautions while charging and recommended rates of charge. Note that the ChargeMaster Plus charge specifications are based on Mastervolt batteries. Specifications for a given chemistry of a different manufacturer may vary. If connecting batteries of a different manufacturer, make sure the manufacturer's recommendations are met.
- 6 Determine voltage of battery by referring to car owner's manual and make sure that output voltage selector switch is set at correct voltage. If charger has adjustable charge rate, charge battery initially at lowest rate. Exception: For a charger not having an output voltage selector switch, determine voltage of battery by referring to car owner's manual and make sure it matches output rating of battery charger.

## 2.10 Grounding instructions

This battery charger should be connected to a grounded, metal, permanent wiring system; or an equipment-grounding conductor should be run with circuit conductors and connected to equipment-grounding terminal or lead on battery charger. Connections to battery charger should comply with all local codes and ordinances.

## 2.11 Warning regarding life support applications

Mastervolt products are not designed to be used as component of medical equipment, unless negotiated in the form of a written agreement between customer and/or manufacturer and Mastervolt. Such agreement will require the equipment manufacturer either to contract additional reliability testing of the Mastervolt parts and/or to commit to undertake such testing as a part of the manufacturing process. Furthermore, the manufacturer must agree to indemnify and not hold Mastervolt responsible for any claims arising from the use of the Mastervolt parts in the life support equipment.

### 3 INSTALLATION

During installation and commissioning, the safety instructions are applicable at all times.

#### 3.1 Unpacking

In addition to the ChargeMaster Plus the delivery includes:

- Mounting bracket to mount the ChargeMaster Plus to a wall;
- Battery temperature sensor;
- MasterBus Terminator;
- User manual

After unpacking, check the contents for possible damage. Do not use the product if it is damaged. If in doubt, contact your supplier

Check from the identification label (see section 1.2) whether the battery voltage is the same as the nominal output voltage of the ChargeMaster Plus (e.g. 24V battery set for a 24V battery charger).

#### 3.2 Environment

Obey the following stipulations during installation:

- The ChargeMaster Plus is designed for indoor use only.
- Ambient temperature: -25°C ... 80°C / -13°F ... 176°F; (power derating above 40°C / 104°F to decrease the internal heat sink temperature).

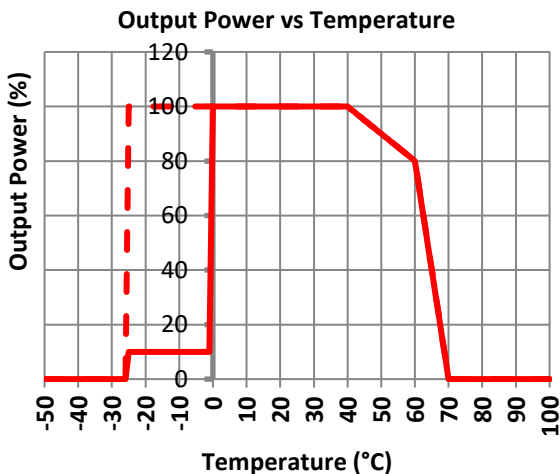

- Humidity: 0-95% non-condensing
- Mount the ChargeMaster Plus vertically, with the connecting cables downwards.
- Do not expose the ChargeMaster Plus to excessive dust, aggressive environments, ammonia or salt.
- Make sure that the hot air that is developed during operation can be discharged. The ChargeMaster Plus must be mounted in such a way that obstruction of the airflow through the ventilation openings will be prevented.
- No objects must be located within a distance of 10 cm / 4 inch around the ChargeMaster Plus.

- Do not locate the ChargeMaster Plus in the same compartment as the batteries.
- Do not install the ChargeMaster Plus straight above the batteries because of possible corrosive sulphur fumes.
- If the ChargeMaster Plus is installed in the immediate vicinity of living areas, take into account that the fan of the ChargeMaster Plus can produce noise when operating.
- Although the ChargeMaster Plus fully complies with all applicable EMC limits, it may still cause harmful interference to radio communication equipment. If such interference appears, it is recommended to increase the separation between the ChargeMaster Plus and the equipment, to relocate the receiving antenna or to connect the equipment to a circuit different from that to which the ChargeMaster Plus is connected.

#### 3.3 Wiring



##### WARNING!

The wire and fuse sizes stated in this manual are given as example only. Prescribed wire and fuse sizes may be different due to local applicable regulations and standards.

##### 3.3.1 DC wiring

Keep in mind that high current will pass through the DC wiring. Keep the cable length as short as possible, this will keep the system efficiency as high as possible. The recommended minimum cross section of the battery cables is:

ChargeMaster Plus model	DC Cable cross section:	
	<3m / 10ft	3-5m / 10-16ft
12/75-3	25mm <sup>2</sup> / AWG2	35mm <sup>2</sup> / AWG1
12/100-3	35mm <sup>2</sup> / AWG1	50mm <sup>2</sup> / AWG0
24/40-3	16mm <sup>2</sup> / AWG4	25mm <sup>2</sup> / AWG2
24/60-3	25mm <sup>2</sup> / AWG2	35mm <sup>2</sup> / AWG2

Use ring terminals on the ends of the wires. The terminals must be crimped with a proper crimping tool. Use the following wire colors for DC wiring color or at least different colors to make a clear distinction between the positive and negative wire from the battery:

Wire color	Meaning	Connect to:
Red	Positive	+ (POS)
Black	Negative	- (NEG)

Lay the positive and negative cables next to each other to limit the electromagnetic field around the cables. The negative cable should be connected directly to the negative post of the battery bank or the ground side of a current shunt. Do not use the chassis frame as the negative conductor. Tighten securely. The positive battery

cable must be fused and connected to the positive post of the battery bank.

The recommended DC fuses for outputs 1, 2 and 3 are:

ChargeMaster Plus model	DC fuse
12/75-3	85A
12/100-3	125A
24/40-3	50A
24/60-3	80A

The fuse with the fuse-holder is available from your local Mastervolt distributor or Customer Service Representative.

### 3.3.2 AC wiring



#### WARNING!

On first connecting to power, make sure the ChargeMaster Plus is in a well-ventilated area as it might spark.



#### WARNING!

The ground wire offers protection only if the enclosure of the ChargeMaster Plus is connected to the safety ground. Connect the ground terminal (PE / GND) to the hull or the chassis.



#### CAUTION!

According to local regulations an RCD/Breaker (also known as GFCI) must be placed in the AC input circuit of the ChargeMaster Plus.

For Australia and New Zealand, the wiring rules are in accordance with AS/NZS 3000.

For a safe installation the correct wire cross section must be applied. Don't use a cross section that is smaller than indicated. See the following table to select the appropriate cross section for the AC wiring (up to 6m / 20ft length):

AC Current	Minimum cross section:	
	in mm <sup>2</sup>	AWG
6-12A	1.5mm <sup>2</sup>	AWG14
12-20A	2.5mm <sup>2</sup>	AWG12
20-32A	4.0mm <sup>2</sup>	AWG10

Connection of AC wiring and recommended wire colors:

- 230V/50Hz installations:

Wire color	Meaning	Must be connected to:
Brown or black	Phase	L1
Blue	Neutral	N
Green/Yellow	Earth	PE / GND

- 120V/60Hz installations (single phase):

Wire color	Meaning	Must be connected to:
Black	Hot or Line	L1
White	Neutral	N
Green	Ground	PE / GND

- 240V/60Hz installations (split phase 120/240VAC):

Wire color	Meaning	Must be connected to:
Black	Hot or Line	L1
Red	Hot or Line	L2
Green	Ground	PE / GND

### 3.4 Batteries

Always follow the instructions published by the battery manufacturer.

ChargeMaster Plus model	Recommended battery capacity	
12/75-3	140Ah -	800Ah
12/100-3	200Ah -	1000Ah
24/40-3	80Ah -	400Ah
24/60-3	120Ah -	500Ah

*Minimum based on Mastervolt GEL batteries.*

### 3.5 Things you need

Make sure you have all the parts you need to install the ChargeMaster Plus:

- ChargeMaster Plus (included).
- Battery temperature sensor with cable and plug (included).
- DC cables to connect the ChargeMaster Plus to the batteries and common negative; see section 3.3.1 for specifications.
- DC fuse holder with a DC fuse, to be integrated in the positive DC cable; see section 3.3.1 for specifications.
- Screws / bolts (Ø 6mm with plugs) to mount the enclosure to a surface. Use mounting materials which are suitable to carry the weight of the ChargeMaster Plus.
- AC cable to connect the AC input to an AC power source. See section 3.3.2.
- Batteries. See section 3.4.
- Appropriate and reliable cable terminals, cable lugs, battery terminals and cord end terminals.

We recommend as a minimum tool kit:

- Socket wrench 13mm to fix the main DC cables.
- Socket wrench 10mm to fix the Safety ground connection.
- Flat blade screw driver 1.0 × 4.0mm to fix the screw terminals of the AC wiring.
- Tools to fix the screws / bolts (Ø 6mm) with plugs to mount the enclosure to a surface.
- Philips screw driver number 2 to open the connection compartment.



### 3.6 Overview connection compartment

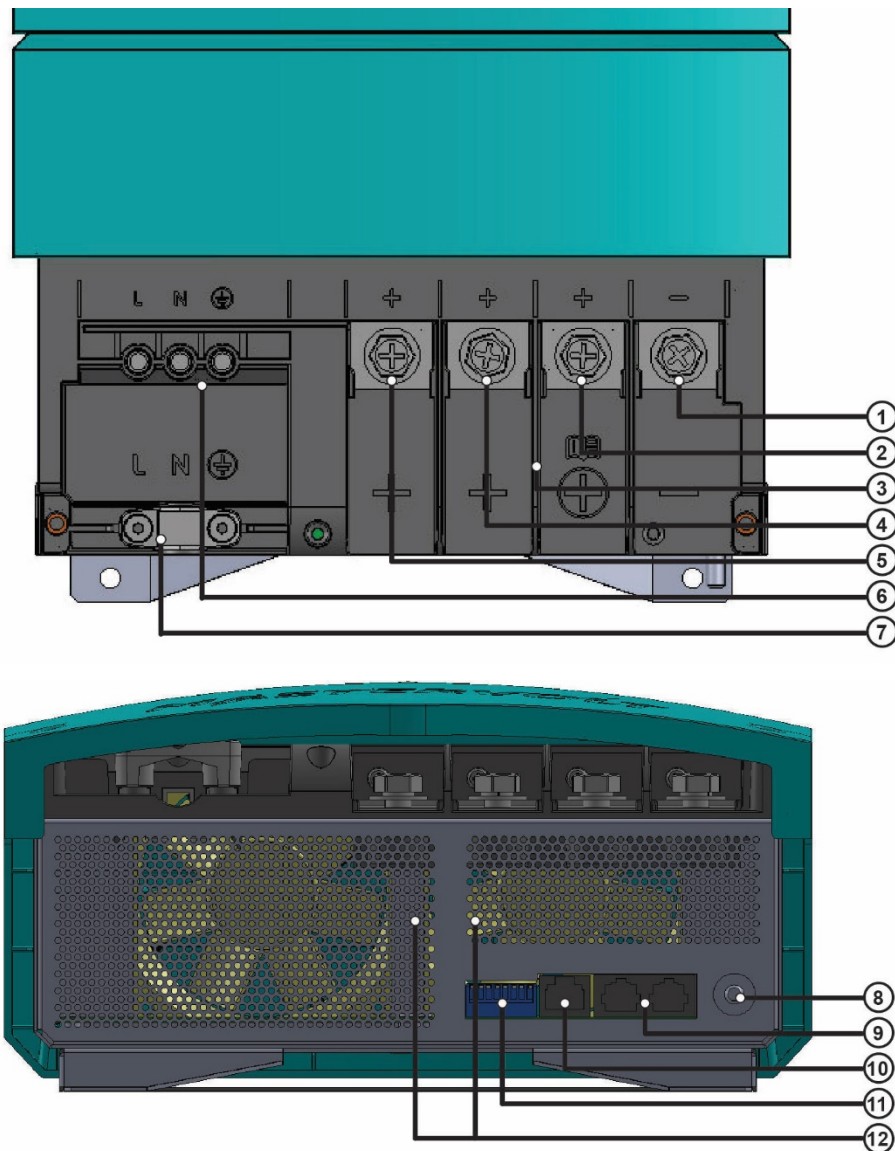

- |   |   |    |                               |
|---|---|----|-------------------------------|
| 1 | Common negative output terminal         | 7  | Cable clip for AC wiring      |
| 2 | Positive terminal charge Smart terminal | 8  | Safety ground connection      |
| 3 | Isolation walls for DC connections      | 9  | MasterBus connection          |
| 4 | Positive terminal charge output 2       | 10 | Temperature sensor connection |
| 5 | Positive terminal charge output 1       | 11 | DIP switches                  |
| 6 | Screw terminals AC input                | 12 | Ventilation openings          |

Figure 2: Connection compartment

#### Notes:

- If the battery temperature remains within 15-25°C, connection of the battery temperature sensor is optional.
- The ChargeMaster Plus is only feasible for the connection of MasterBus compatible remote control panels.
- When creating a parallel system of multiple ChargeMaster Plus units, the units should be excluded from any isolation measurement system.

### 3.7 Connection example

This schematic illustrates the general placement of the ChargeMaster Plus in a circuit. It is not meant to provide detailed wiring instructions for any particular electrical installation.

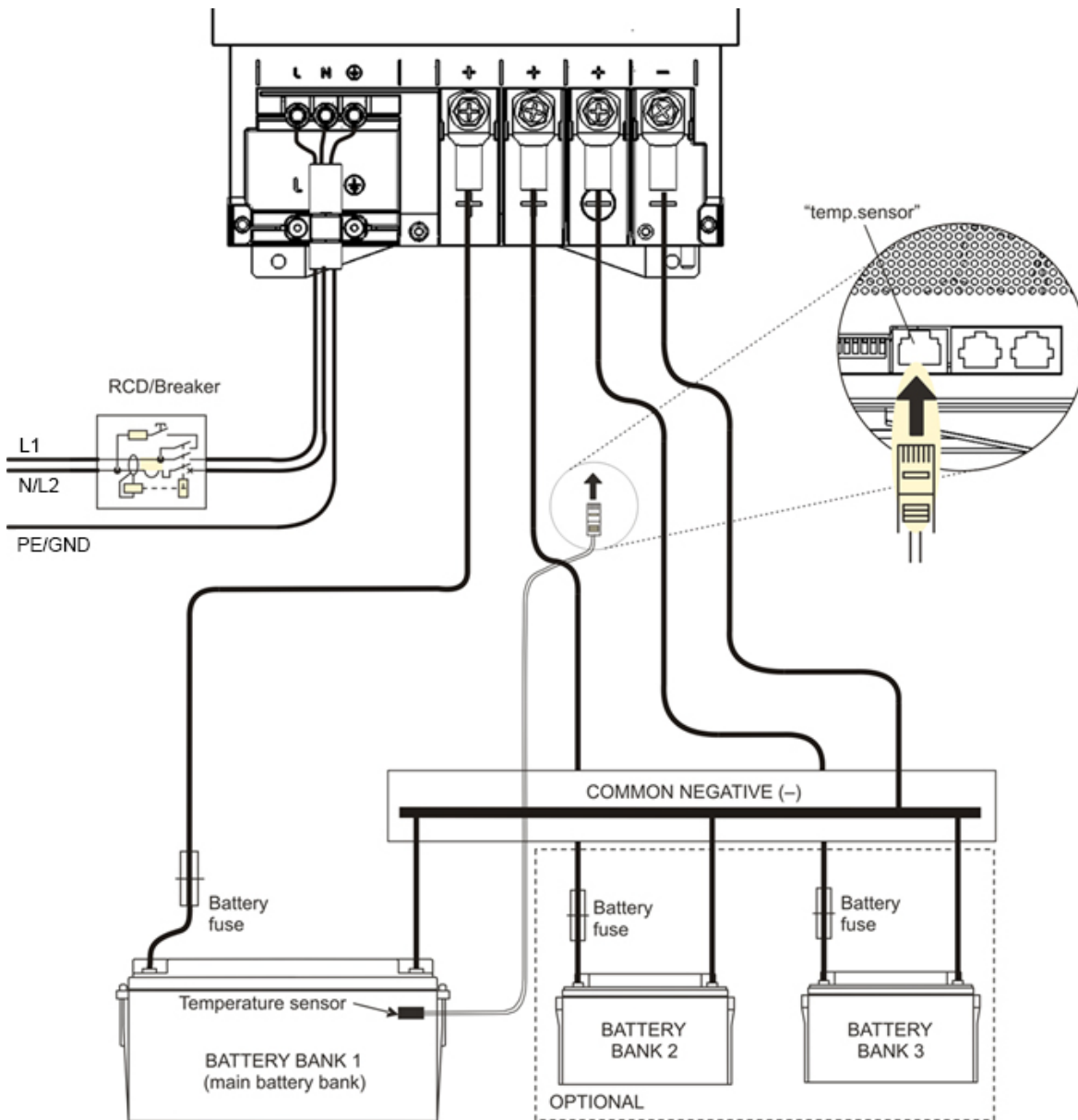

Figure 3: Installation drawing of the ChargeMaster Plus



#### WARNING

All electrical systems (AC and DC) must be disconnected from any power source during the entire installation!



#### CAUTION!

Too-thin cables and/or loose connections can cause dangerous overheating of the cables and/or terminals. Therefore, tighten all connections well, in order to limit transition resistance as far as possible. Use cables of the correct size.



#### CAUTION!

Short circuiting or reversing polarity may lead to serious damage to the batteries, the ChargeMaster Plus, the cabling and/or the terminal connections. Fuses between the batteries and the ChargeMaster Plus cannot prevent damage caused by reversed polarity. The damage as a result of reverse polarity is detectable by the service department and is not covered by the warranty.

## 3.8 Installation step-by-step

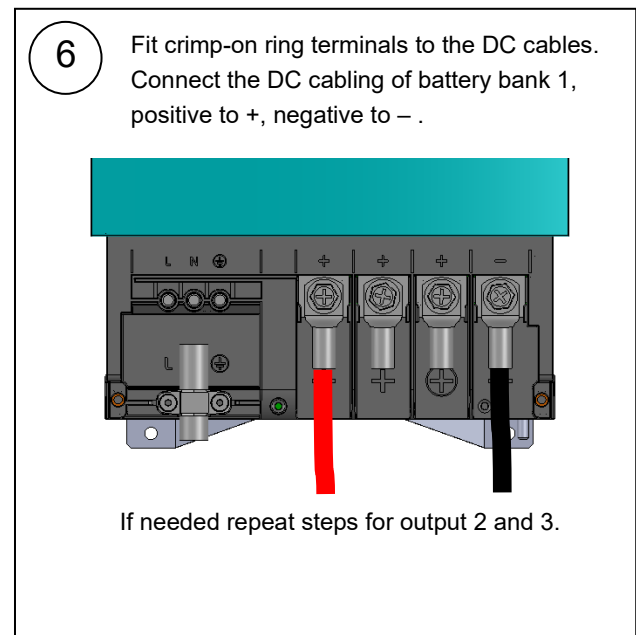
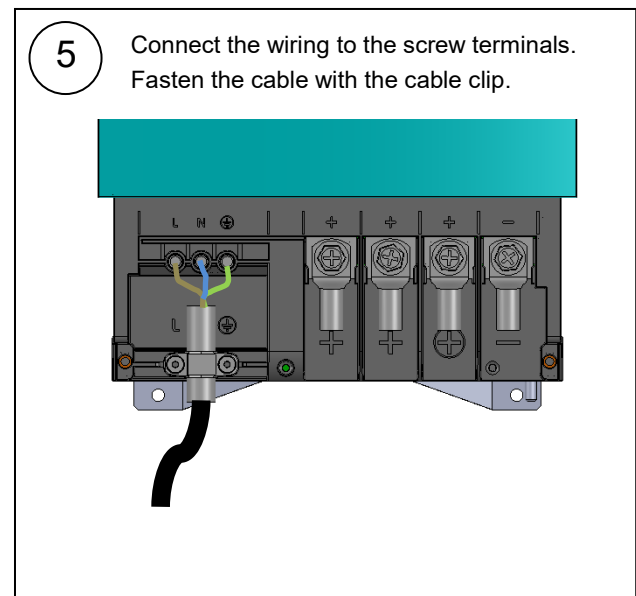
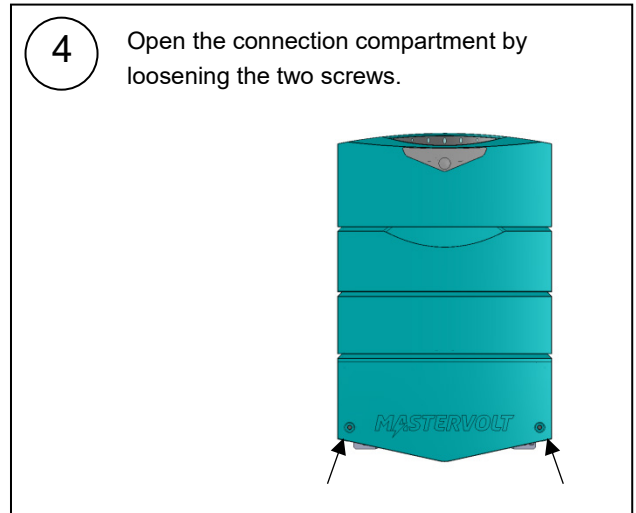
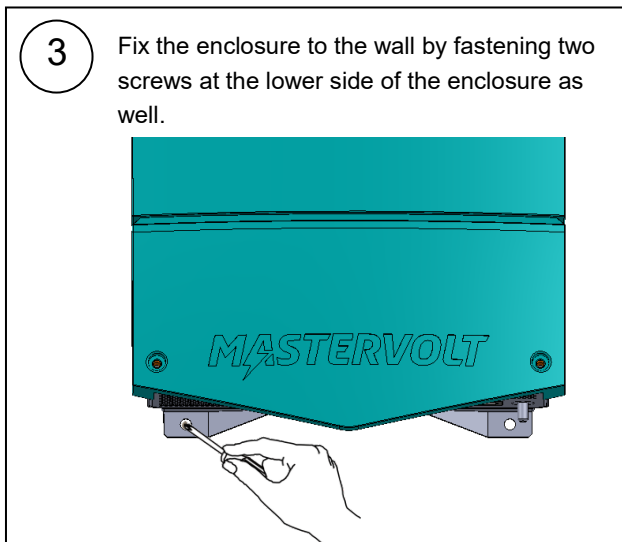
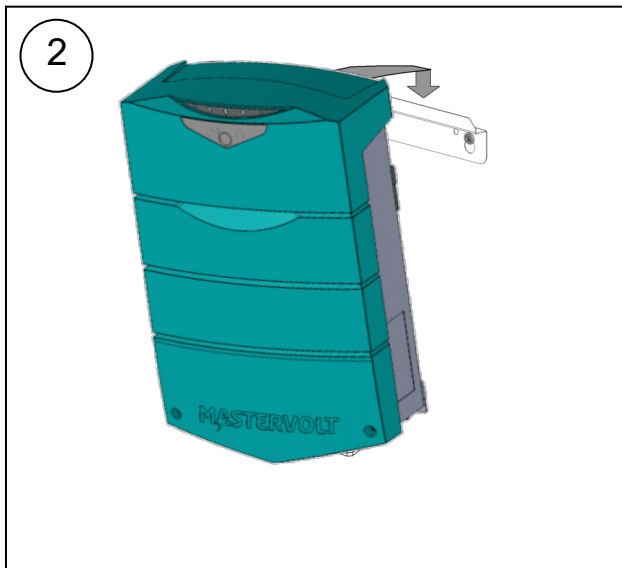
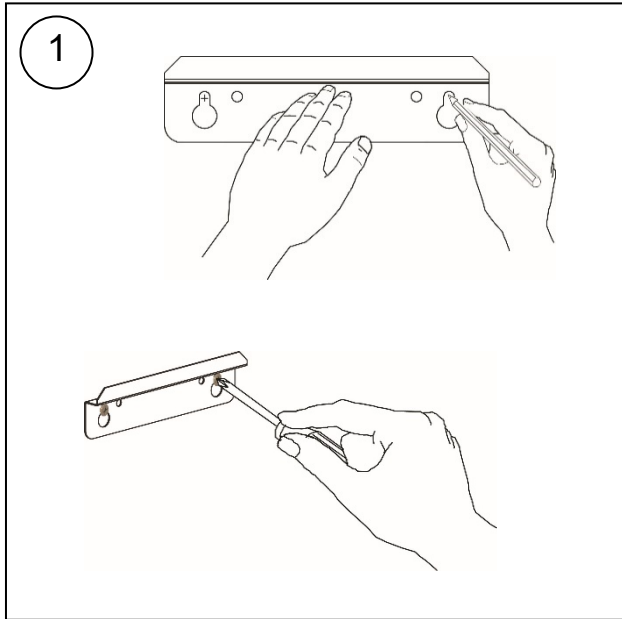

7

Attach the battery temperature sensor to the casing of battery bank 1. Plug the temperature sensor cable into the “temp.sensor” jack.

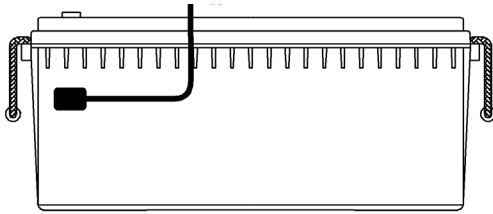
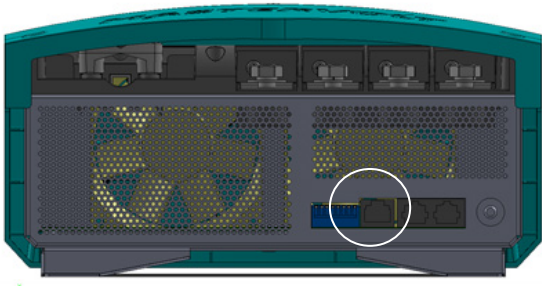

8

Option: Connect the ChargeMaster to the MasterBus network.

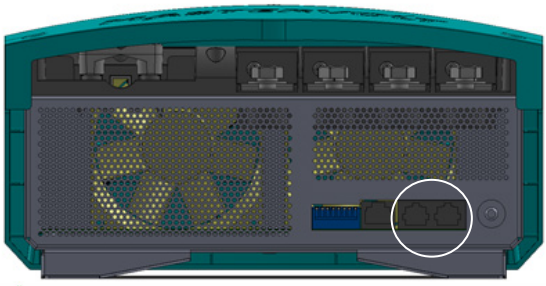

9

If required, use a small screw driver to change DIP switch settings. See section 4.1. Use a small screw driver for adjustment of the DIP switches.

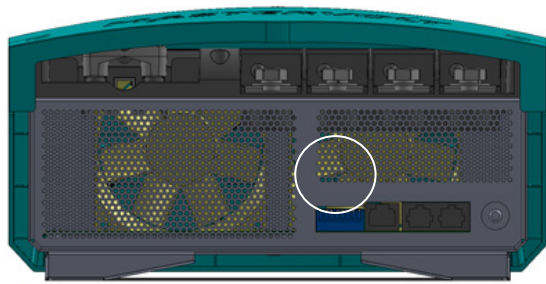

10

Check all wiring; see also Figure 3 for wiring details.

11

Close the connection compartment by fixing the four screws.



12

Continue with section 3.9 for commissioning of the ChargeMaster.

### 3.9 Commissioning after installation

Note that when your ChargeMaster Plus is not new, former users may have changed the settings. Reset the ChargeMaster Plus back to factory settings when there is any doubt (see section 4.2).

DIP switches, if required, must be set *prior* to commissioning. All other settings can only be set *after* commissioning. See section 4.1 for DIP switch settings.

- 1 Check the wiring; positive connected to positive (red cables), negative connected to negative (black cables).
- 2 When all wiring is OK, place the DC fuse(s) to connect the batteries to the ChargeMaster Plus.



#### WARNING

When placing this fuse, a spark might occur, caused by the capacitors used in the ChargeMaster Plus. This is particularly dangerous in places with insufficient ventilation. Due to the gassing of the batteries, an explosion can occur. Avoid having flammable materials close by.

- 3 Switch on the AC power supply.
- 4 Press and hold the MODE button (Figure 5) for 3 seconds to switch the charger on and initiate the charging process.

### 3.10 MasterBus (optional)

During first commissioning the ChargeMaster Plus will be recognized by the MasterBus network automatically.

Some settings can only be changed via the MasterBus interface. See section 4.2 for an overview of all available MasterBus settings. Refer to the user manual of the remote control panel to change these settings.

#### About MasterBus



All devices that are compatible with MasterBus are marked with the MasterBus symbol.

MasterBus is a CAN based, fully decentralized data network for communication between Mastervolt devices. MasterBus is used as power management system for all connected equipment, such as the inverter, battery charger, generator and many more.

Every device that is compatible with MasterBus is equipped with two data ports. The devices are simply chained together, forming a local data network. Monitoring panels such as the EasyView 5 can be used for monitoring and control of all connected MasterBus equipment.

#### Event based commands

With MasterBus a device can be programmed to initiate an action at another connected device. This is done by means of *event-based commands*.

### 3.11 Decommissioning

If it is necessary to put the ChargeMaster Plus out of operation, follow the instructions in order of succession as described below:

- 1 Turn AC power off.
- 2 Switch the ChargeMaster Plus to stand-by (see chapter 5).
- 3 Remove the DC fuse(s) and disconnect the batteries.
- 4 Switch the RCD/Breaker of the AC input to the OFF position and, if required, disconnect the AC mains.
- 5 Open the connection compartment of the ChargeMaster Plus.
- 6 Check with a suitable voltage meter whether the inputs and the outputs of the ChargeMaster Plus are voltage free.
- 7 Disconnect all the wiring.

Now the ChargeMaster Plus can be demounted in a safe way.

### 3.12 Storage and transportation

When not installed, store the ChargeMaster Plus in the original packing, in a dry and dust free environment.

Always use the original packing for transportation. Contact your local Mastervolt Service Centre for further details if you want to return the apparatus for repair.

### 3.13 Re-installation

To reinstall the ChargeMaster Plus, follow the instructions as described in this chapter.

## 4 SETTINGS

Adjustment of the settings of the ChargeMaster Plus can be made in two different ways:

- By means of DIP switches; see section 4.1;
- Via the MasterBus network; see section 4.2.



### CAUTION!

Invalid settings of the ChargeMaster Plus can cause serious damage to your batteries and/or the connected load! Only authorised personnel may adjust settings.

### 4.1 DIP switch settings

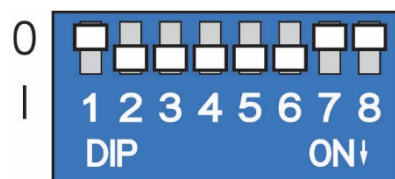

Figure 4: DIP switches

If all DIP switches are in the 0 (OFF) position, changes can only be made by via the MasterBus network.

After setting the DIP switches, the ChargeMaster Plus needs to be switched off and on, in order for the settings to take effect.

DIP SWITCH	Output 1&2			Smart terminal 3				
	1	2	3	4	5	6	7	8
Constant voltage	0	0	1					
AGM	0	1	0					
GEL	0	1	1					
Flooded	1	0	0					
AGM spiral	1	0	1					
Flooded traction	1	1	0					
Flooded calcium	1	1	1					
10A starter				0	0	0		
Starter				0	0	1		
Starter + alternator				0	1	0		
Follow main				0	1	1		
Follow main + alternator				1	0	0		
12V constant voltage				1	0	1		
24V constant voltage				1	1	0		
12V 3-step+ AGM				1	1	1	0	0
12V 3-step+ GEL				1	1	1	0	1
12V 3-step+ flooded				1	1	1	1	0
12V 3-step+ AGM spiral				1	1	1	1	1

The example in Figure 4 has the following DIP switch settings:

- Main output 1 and 2; Charging GEL batteries
- Smart terminal 3; set to 12V 3-step+
- Smart terminal 3; charging 12V AGM battery

See sections 5.4 and 5.5 on pages 21 and 22, for more information on charge voltage settings and Smart terminal 3.

### 4.2 MasterBus functions

Adjustment of the settings of the ChargeMaster Plus can be made via the MasterBus network (by means of an USB interface connected to a PC with MasterAdjust software). Some settings can only be changed via the MasterBus interface.

#### 4.2.1 MasterBus communication

MasterBus communication can be set to *Smart on* or *Always on*.

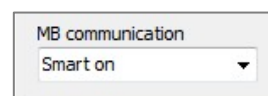

The following table explains the difference.

AC available	ChargeMaster Plus mode	MasterBus communication		MasterBus powering
		Smart on	Always on	
No	Standby	No	Yes	No
No	On	Yes	Yes	No
Yes	Standby	Yes	Yes	Yes
Yes	On	Yes	Yes	Yes

As can be seen above, the ChargeMaster Plus is a MasterBus powering device only if AC is available. Depending on the threshold level, MasterBus powering is also available when the alternator mode is enabled.

On first use, MasterBus powering is on.

#### 4.2.2 Current control

If the available power at the AC input is limited. The ChargeMaster can be configured to reduce input current. The Current Control level should be set equal or lower than the value of the external circuit breaker, which protects the incoming AC power. For example, when the external AC power is limited by a 6A fuse, the Current

Control level should be set to ≤6A. The AC input current of the ChargeMaster Plus will be reduced to 6A.

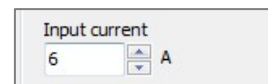

The Current Control level can be adjusted by means of MasterAdjust software or by using an optional remote control, like the EasyView 5.

#### 4.2.3 MasterShunt

A MasterShunt can be coupled with output 1 of the ChargeMaster Plus.

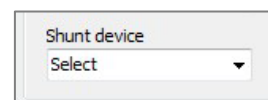

The actual measurement data of the MasterShunt will be used to charge the batteries. Refer to the manual of the MasterShunt for information on how to configure your system.

#### 4.2.4 Li-ion Battery MLI Ultra

The ChargeMaster Plus can be used with a Li-ion battery MLI Ultra. Refer to the manual of the Li-ion battery MLI Ultra for information on how to configure your system.



#### WARNING!

Before using the Li-ion battery, it must be properly installed and commissioned!

#### 4.2.5 Monitoring

Value	Meaning	Default	Value range
<b>General</b>			
Device state	Shows charger state (Charging / Stand-by / Alarm)		(read only)
Charger state	Actual state of charge process: Off/bulk/absorption/float/suspended		(read only)
Charger	Function to toggle the charger state		On / Stand-by
Input current	Option to set the maximum AC input current level to prevent a generator or shore fuse from overload	20	0-20A
Battery temp.	Actual temperature of the main battery bank (in °C)		(read only)
<b>Output 1</b>			
Output 1	Output state (Off/pre-float/on)		(read only)
Output 1	Voltage of charge output 1		(read only)
Output 1	Output current of charge output 1		(read only)
Shunt device	A connected MasterShunt can be chosen for feedback on the charged battery.	Not connected	(read only)
<b>Output 2</b>			
Output 2	Output state (Off/pre-float/on)		(read only)
Output 2	Voltage of charge output 2		(read only)
Output 2	Output current of charge output 2		(read only)
<b>Smart Terminal</b>			
Output 3	Output state (Off/pre-float/on/smart terminal)		(read only)
Output 3	Voltage of charge output 3		(read only)
Output 3	Output current of charge output 3		(read only)

#### 4.2.6 Alarm

Value	Meaning	Value range
<b>Alarm status</b>		
Bat. temp. high	Battery temperature too high	(read only)
TS error	Temperature sensor error	(read only)
AC error	AC input (mains) error	(read only)
<b>Output 1</b>		
Battery high	DC output voltage is too high	(read only)
Battery low	DC output voltage is too low	(read only)
Shunt mismatch		(read only)
Reverse polarity	DC + and DC –are connected in reverse (this will damage the charger)	(read only)
<b>Output 2</b>		
Battery high	DC output voltage is too high	(read only)
Battery low	DC output voltage is too low	(read only)
Reverse polarity	DC + and DC –are connected in reverse (this will damage the charger)	(read only)
<b>Smart terminal</b>		
Battery high	DC output voltage is too high	(read only)
Battery low	DC output voltage is too low	(read only)
Reverse polarity	DC + and DC –are connected in reverse (this will damage the charger)	(read only)

#### 4.2.7 History

This menu shows the absolute maximum readings.

Value	Meaning	Value range
<b>Charger</b>		
Days running	Total run time in charger mode	(read only)
<b>Output 1</b>		
Highest voltage	Highest detected DC voltage output 1	(read only)
Lowest voltage	Lowest detected DC voltage output 1	(read only)
Total Ah's	Total charged Ah's	(read only)
<b>Output 2</b>		
Highest voltage	Highest detected DC voltage output 2	(read only)
Lowest voltage	Lowest detected DC voltage output 2	(read only)
Total Ah's	Total charged Ah's	(read only)
<b>Smart terminal</b>		
Highest voltage	Highest detected DC voltage Smart terminal	(read only)
Lowest voltage	Lowest detected DC voltage Smart terminal	(read only)
Total Ah's	Total charged Ah's	(read only)
Total Ah's in	Total charged Ah's using the smart terminal as input	(read only)

#### 4.2.8 Configuration

Below parameters can be changed via the MasterBus network by means of a remote control panel or by means of an interface connected to a PC with MasterAdjust software. See applicable user manuals for details.

Value	Meaning	Factory setting	Value range
<b>Device</b>			
Language	Menu language of this device	English	EN, NL, DE, FR, ES, IT, NO, SV, FI, DA
Name	Name of this device. This name will be recognized by all devices connected to the MasterBus	CHG ChargeMaster	0-12 chars
MB communication	Select if MasterBus communication is available when only DC power is available.	Smart on	Smart on, Always on
<b>Charger</b>			
Method	Charge method	3-Step+	3-Step+, constant voltage
Maximum current	Maximum DC output current	Depending on model, 100%	Depending on model 20-100%
Battery type	Type of battery	Flooded	User defined, AGM, GEL, Flooded, AGM Spiral, Flooded traction, Flooded calcium, MLI
Temp. compensate	Temperature depended charge voltage compensation	-0,030V/°C/ -0,060V/°C	-1,000/+1,000V/°C
Smart terminal	Smart terminal operation mode	10A Starter	Starter, Starter+alternator, Follow main, Follow main+alternator, 12V constant voltage, 24V constant voltage*, 12V 3-step+*
Maximum current	Smart terminal maximum DC output current	40/20A	5-40/20A
Input threshold	Voltage threshold used to switch over when Smart Terminal acts as VSR	13,75/27.50V	8-16/16-32V
Input current	Smart terminal maximum DC input current	40/20A	5-40/20A
<b>Bulk</b>			
Voltage	Bulk voltage (@ 25°C); see section 5.4	14.40/28.80V	0-15.50/0-31.00V
Minimum time	Minimum time of the Bulk phase since <i>Start bulk timer</i>	120sec	0-240sec
Start time at	Battery voltage trigger point to start the bulk timer	13.25/26.50V	(read only)



Value	Meaning	Factory setting	Value range
Maximum time	Maximum time of the Bulk phase since <i>Start bulk timer</i>	480 min	0-1440min
<b>Absorption</b>			
Voltage	Absorption voltage (@ 25°C); see section 5.4	14.25/28.50V	0-15.50/0-31.00V
Maximum time	Maximum absorption timer	240min	0-1440min
Return Amps	Return amps. If the charge current drops below this level, the charger switches from the Absorption to the Float stage (% of $I_{max}$ )	6%	0-50%
Minimum time	Minimum absorption timer	15min	0-240min
<b>Float</b>			
Voltage	Float voltage (@ 25°C); see section 5.4	13.25/26.50V	0-15.50/0-31.00V
Return to bulk	Return to bulk voltage; If the battery voltage stays below this level for at least the <i>Return to bulk delay time</i> , the charger will start the Bulk stage	13.25/26.50V	0-15.50/0-31.00V
Return to bulk	Return to bulk delay time, see <i>Return to bulk voltage</i>	30sec	0-240sec
<b>Alarm levels</b>			
High alarm on	Upper threshold level to trigger the Battery high alarm	15,25/30.50V	0-16.00/0-32.00V
High alarm off	Lower threshold level to stop the Battery high alarm	14,75/29,50V	0-16.00/0-32.00V
Low alarm off	Upper threshold level to stop the Battery low alarm	11.00/22.00V	0-16.00/0-32.00V
Low alarm on	Lower threshold level to trigger the Battery low alarm	10.00/20.00V	0-16.00/0-32.00V
Alarm delay	Delay time before the alarm is triggered	30sec	5-60sec
<b>Output 1</b>			
Name	Name of this output	Output 1	0-16 chars
Shunt device	Selection of the MasterShunt to which output 1 of the ChargeMaster Plus is connected	No connection	No connection, MSH + Product Name
<b>Output 2</b>			
Name	Name of this output	Output 2	0-16 chars
<b>Smart terminal</b>			
Name	Name of this output	Output 3	0-16 chars

\*24V models only

#### 4.2.9 Events

With MasterBus a device can be programmed to initiate an action at another connected device. This is done by means of event based commands.

Value	Meaning	Factory setting	Value range
<b>Events</b>			
Event x source	Event-based command. ChargeMaster Plus event that should result in an action by another device on the <i>MasterBus</i> network.	Disabled	(see <i>Event source</i> list, section 4.2.10)
Event x target	Select a connected MasterBus device that should take action due to a ChargeMaster Plus event.		Selectable targets are system dependent
Event x command	Action to be taken by the target device.		See command list in selected device manual
Event x data	Data is linked to the command. <i>On</i> changes the status to On at the first signal. <i>Off</i> changes the status to Off at the first signal. <i>Copy</i> lets the status follow the input. <i>Copy Invert</i> lets the status follow the opposite of the input <i>Toggle</i> changes the status at the 1 <sup>st</sup> signal and back at the 2 <sup>nd</sup> signal. It is used in combination with a pulse switch.		Off, On, Copy, Copy Invert, Toggle
Event x+1	The next event appears after enabling Event x.	Disabled	See Event x.

#### 4.2.10 Events source

The ChargeMaster Plus can be configured as an *event source*. An event source can be used to initiate an *event command* and an *event action* by another device that is connected to the MasterBus.

Event sources	Description
Device state	State of the ChargeMaster Plus serves as an event source
Bulk	Bulk state of charge serves as an event source
Abs	Absorption state of charge serves as an event source
Float	Float state of charge serves as an event source
Failure	Any fault condition of the ChargeMaster Plus serves as an event source

#### 4.2.11 Event target

The *ChargeMaster Plus* can be configured as an *event target by other devices* on the MasterBus network. When the *ChargeMaster Plus* is configured as an *event target* by another device, this device can initiate an *event command* and an *event action* to be performed by the *ChargeMaster Plus*.

Event command	Description
Charger on	Command to switch on the ChargeMaster Plus
Bulk	Command to start the Bulk state of charge
Abs	Command to start the Absorption state of charge
Float	Command to start the Float state of charge
Suspend charging	When using a Li-ion battery MLI Ultra, programming this event is obligatory. Refer to the manual of the Li-ion battery MLI Ultra.

## 5 OPERATING INSTRUCTIONS

### 5.1 Introduction

The Mastervolt ChargeMaster Plus is a fully automatic battery charger. This means that under normal circumstances it can be left switched on with AC power and batteries connected. The ChargeMaster Plus is suitable for charging of Li-ion and lead-acid batteries, which may include maintenance-free, low maintenance, AGM/spiral, gel or deep-cycle batteries. It operates on both 230V and 120V.



#### WARNING

The MLI charging voltages on this charger fit the Mastervolt Li-ion (MLI) batteries but do not necessarily fit other Li-ion batteries! Always follow the instructions provided by the battery manufacturer!

### 5.2 Switching on / stand-by

The ChargeMaster Plus is activated by keeping the MODE button pressed for approx. 3 seconds. The MODE LED will illuminate green. If necessary and if AC power is available, the ChargeMaster Plus will start to charge the batteries.

**Note:** Once switched on, the ChargeMaster Plus automatically resumes operation after it was disconnected from an AC source temporarily.

By holding the MODE button pressed again for approx. 3 seconds, the ChargeMaster Plus will switch back to stand-by: the ChargeMaster Plus stops and the MODE LED illuminates red.



#### WARNING

Switching the ChargeMaster Plus to “stand-by” does not cut off the connection to the batteries or the AC source. This means that voltages are still present inside the apparatus.

### 5.3 Status display

The status display at the front side of the ChargeMaster Plus enables you to control the charger and monitor the charging process.

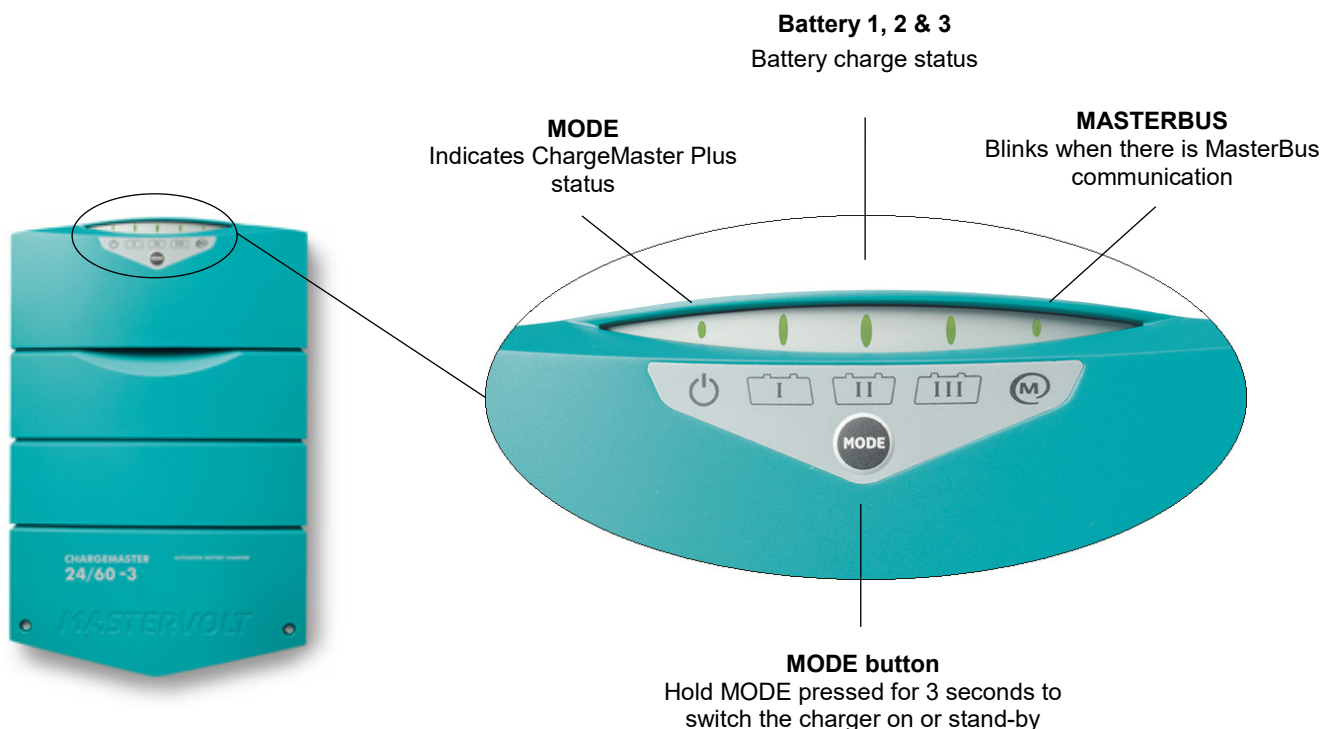







Figure 5: ChargeMaster Plus status display

**Note:** The ChargeMaster Plus can also be operated and monitored remotely via a MasterBus remote control panel. See section 4.2 for details.



The status display has a 3 level menu. Menu navigation is done by shortly pressing the MODE button. After each press the next menu level is shown. The MODE LED color indicates the level that is being shown.

Menu	MODE LED color	Meaning
Level 1	Green	Status menu
Level 2	Orange	Output power menu
Level 3	Red	Error menu



### Status

Display	LED	State	Meaning
	MODE	Solid green	ChargeMaster Plus on
		Solid red	ChargeMaster Plus stand-by
		Blink fast red	Error, navigate to error menu
	Battery I	Blinking medium fast green	Battery in bulk stage
		Blinking slow green	Battery absorption stage
		Solid green	Battery in float stage
	Battery II	Blinking medium fast green	Battery in bulk stage
		Blinking slow green	Battery absorption stage
		Solid green	Battery in float stage
	Battery III	Blinking medium fast green	Battery in bulk stage
		Blinking slow green	Battery absorption stage
		Solid green	Battery in float stage
	MasterBus	Blinking green	MasterBus communication

### Output power

Display	LED	State	Meaning
	MODE	Solid orange	Output power menu
	Battery I	Solid orange	Total output power 0-25%
	Battery II	Solid orange	Total output power 26-50%
	Battery III	Solid orange	Total output power 51-75%
	MasterBus	Solid orange	Total output power 76-100%

### Error

Error	LED	State	Meaning	What to do
	MODE	Blink fast red	Error menu	
	Battery I	Blink fast red	Reverse polarity	Check battery connection
	Battery II	Blink fast red	AC error	Check AC voltage/frequency
	Battery III	Blink fast red	DC error	Check battery voltage
	MasterBus	Blink fast red	Temperature sense error	Check temperature sensor

### 5.4 The 3-step+ charge process

Battery charging is accomplished in three automatic stages: BULK, ABSORPTION and FLOAT.

The first step is the BULK phase, in which the output current of the charger is 100%, and the greater part of the capacity of the battery is rapidly charged. The current charges the batteries and gradually the voltage rises to the BULK voltage 14.25V respectively 28.5V at 25°C/77°F.

The duration of this phase depends on the ratio of battery to charger capacity, and the battery state of charge.

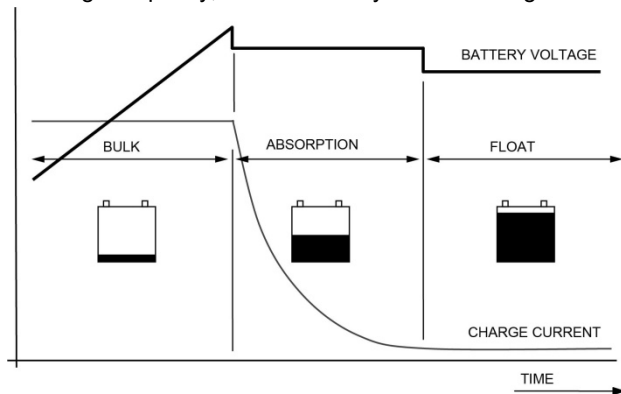

Figure 6: 3-step charge process

The BULK phase is followed by the ABSORPTION phase. Absorption charging starts when the voltage on the batteries has reached the BULK voltage, and ends when the battery is completely full. Battery voltage remains constant at 14.25V/28.5V at 25°C/77°F throughout this stage, and the charge current depends on the degree to which the battery was initially discharged, the battery type, the ambient temperature, etc. With a flooded battery this stage lasts approx. 4h, with gel and AGM around 3h. Once the battery is 100% full, the ChargeMaster Plus automatically switches over to the FLOAT phase. In FLOAT, the ChargeMaster Plus switches to a stabilized 13.25V/26.5V (Flooded), 13.8V/27.6V (Gel/AGM) or 13.5V/27V (MLI) at 25°C/77°F.

Connected DC loads are powered directly by the charger. If the load exceeds the charger capacity, the required additional power comes from the battery, which will be progressively discharged until the charger automatically switches back to the bulk phase. Once consumption decreases, the charger goes back to normal operation of the 3-step charge system.

As the ChargeMaster Plus is equipped with a 3-step+ charge system, the batteries can also remain connected to the ChargeMaster Plus during winter. One hour every 14 days the charger automatically switches to absorption to keep the battery running properly and prolong its life span. The three-step plus charge system is also safe for all the connected equipment. See also the 3-Step+ charging characteristics of flooded batteries on page 27.

#### 5.4.1 Charge voltages

	Bulk	Absorption	Float
AGM or GEL	14.25 / 28.5	14.25 / 28.5	13.80 / 27.6
Flooded or AGM spiral	14.25 / 28.5	14.25 / 28.5	13.25 / 26.5
Flooded traction	14.55 / 29.1	14.55 / 29.1	13.25 / 26.5
Flooded calcium	14.65 / 29.3	14.65 / 29.3	13.30 / 26.6
MLI	14.25 / 28.5	14.25 / 28.5	13.50 / 27.0

#### 5.4.2 Pre-float

The ChargeMaster Plus can automatically switch each individual output from absorption to pre-float stage. In pre-float, the charge voltage is 0.7V lower than in absorption stage. Pre-float ensures batteries that are nearly full don't receive the higher charge voltage needed in the absorption stage. This prevents over-charging, extending the lifespan of the batteries.

#### 5.4.3 Temperature compensated charging

By installing the battery temperature sensor, the charge voltages are automatically adapted for deviating temperatures.

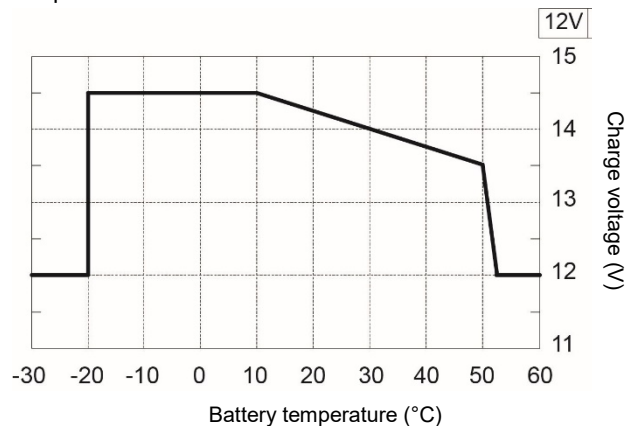

Figure 7: Temperature compensated charging

When the battery temperature is low, the charge voltage increases. On the other hand, when the battery temperature is high, the charge voltage is decreased. Overcharge and gassing are prevented this way. This will extend the life of your batteries.

#### 5.4.4 Flat battery support

The ChargeMaster Plus automatically detects a flat battery and will initiate the flat battery charge curve described in the following table.

UBat	Voltage	Output power
12V	0.00V – 2.50V	15%-30% of I <sub>max</sub>
24V	0.00V – 5.00V	
12V	2.50V – 8.00V	25% of I <sub>max</sub>
24V	5.00V – 16.00V	
12V	8.00V – 10.00V	linear from 25% - 100% of I <sub>max</sub>
24V	16.00V – 20.00V	
12V	10.00V – 14.25V	100% of I <sub>max</sub>
24V	20.00V – 28.50V	
12V	>14.25	Limited by P <sub>max</sub>
24V	>28.50	

## 5.5 Smart terminal - Output 3

The ChargeMaster Plus is equipped with three full outputs. The total output current is divided over these three outputs. See section 3.6 for connections.

Output 3 is the Smart terminal, which can be current limited and can serve as an output and as an input to charge battery 1 & 2. See also section 4.1 on page 14.

The Smart terminal has the following operating modes:

- 10A starter
- Starter
- Starter + alternator
- Follow main
- Follow main + alternator
- 12V constant voltage
- 24V constant voltage
- 12V 3-step+

### 5.5.1 10A starter

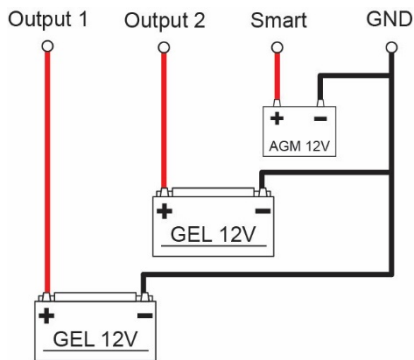

Outputs 1 and 2 are configured as full outputs. Smart terminal 3 is current limited to 10A to safely charge a starter battery.

### 5.5.2 Starter

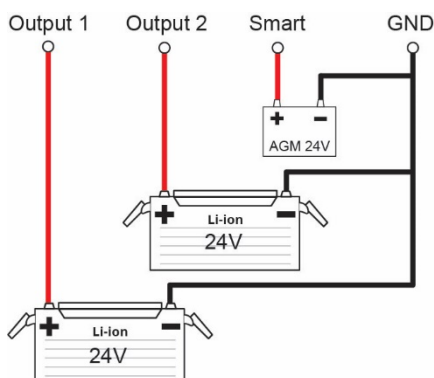

Outputs 1 and 2 are configured as full outputs. Smart terminal 3 is current limited to be able to charge a starter battery. A 24V charger can charge a 24V starter battery, or a 12V starter battery with its own charging profile. Settings are configured via MasterBus, see section 4.2.

### 5.5.3 Starter + alternator

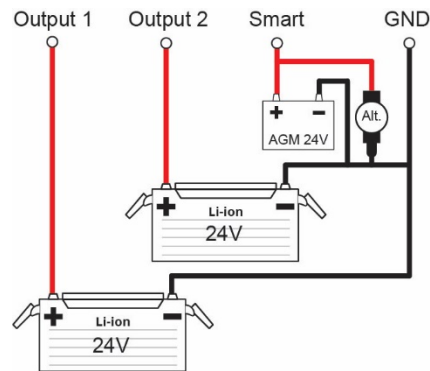

Outputs 1 and 2 are configured as full outputs. Smart terminal acts as a VSR (Voltage Sensitive Relay). When there is no AC power available and the alternator is charging the starter battery, the alternator can also be used to charge batteries 1 and 2. The threshold voltage which is used to switch over can be configured via MasterBus, see section 4.2.

### 5.5.4 Follow main

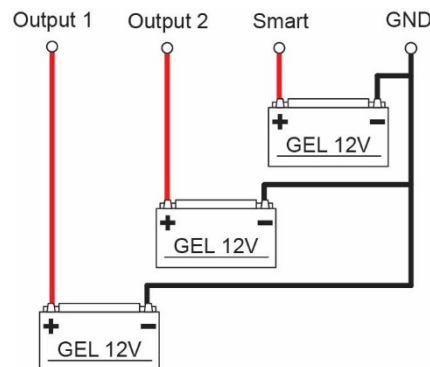

Operation mode for 3 batteries, the charger is configured with 3 full outputs. All batteries are charged with the same settings.

### 5.5.5 Follow main + alternator

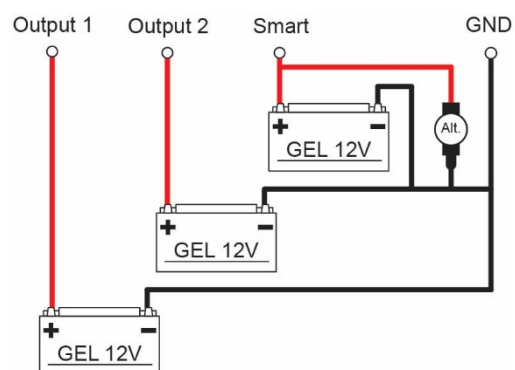

Operation mode for 3 batteries, the charger is configured with 3 full outputs. All batteries are charged with the same settings. Smart terminal acts as a VSR (Voltage Sensitive Relay). When there is no AC power available and the alternator is charging the starter battery, the alternator can also be used to charge battery 1 & 2. The threshold voltage which is used to switch over is configured via MasterBus, see section 4.2.

### 5.5.6 12V constant voltage

Outputs 1 and 2 are configured as full outputs. Smart terminal is current limited and set to 12V constant voltage.

### 5.5.7 24V constant voltage (24V model only)

Outputs 1 and 2 are configured as full outputs, Smart terminal is current limited and set to 24V constant voltage.

### 5.5.8 12V 3-step+ (24V model only)

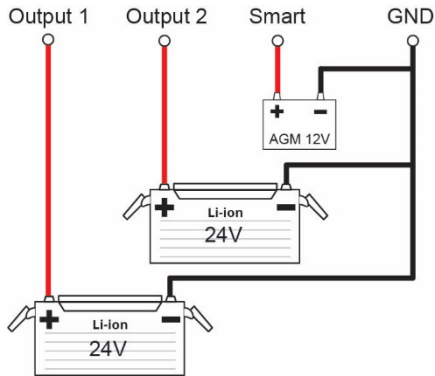

Outputs 1 and 2 are configured as full outputs. Smart terminal is current limited and set to 3-step+ charge process. In 12V 3-step+ configuration the following battery types can be selected: AGM, GEL, flooded, AGM Spiral.

The maximum current is set to 10A by default but can be changed in the configuration [5-10A].

### 5.6 Maintenance

No specific maintenance to the ChargeMaster Plus is required. Examine your electrical installation on a regular basis, at least once a year. Defects such as loose

connections, burnt wiring etc. must be corrected immediately.

If necessary, use a soft clean cloth to clean enclosure of the ChargeMaster Plus. Do not use any liquids or corrosive substances, such as solvents, alcohol, petrol or abrasive components.

### 5.7 Failures

The ChargeMaster Plus is protected against overload, short circuit, overheating and under and over voltage. If a fault condition occurs, the MODE button turns red and the Battery 1, 2 & 3 LED indicate an error code. See section *Status display* for an explanation.



#### CAUTION!

The ChargeMaster Plus is not protected against serious over voltage (>275VAC) on the AC input.

**Note:** As long as there is no error code shown, no failure is detected: the ChargeMaster Plus is operating normally!

### 5.8 History

Connect the ChargeMaster Plus to MasterBus in order to be able to see the history data stored in the ChargeMaster Plus.

## 6 TROUBLE SHOOTING

If you cannot solve a problem using the fault finding table, contact your supplier or Mastervolt. Make sure you have the part and serial number at hand.

Malfunction	Possible cause	What to do
No output voltage and/or current	No AC input	Check AC wiring, check remote control panel.
	AC input voltage too low (< 75VAC)	Check input voltage, check generator.
	AC input frequency out of range	Check input voltage, check generator.
Output voltage too low, charger supplies maximum current	Load connected to the batteries is larger than charger can supply.	Reduce load taken from the batteries.
	Batteries not 100% charged	Measure battery voltage. After some time, this will be higher.
	Wrong setting of the charge voltage	Check settings (see chapter 4).
Charge current too low	Batteries almost fully charged	Nothing, this is normal when the battery is almost fully charged.
	High ambient temperature	Nothing; if ambient temperature is more than the setting limit, the charge current is automatically reduced.
	Low AC input voltage. At lower AC input voltages, the charge current is reduced.	Check AC input voltage.
Batteries not fully charged	Charge current too low	See "Charge current too low" in this table.
	Current to load is too high	Reduce load taken from the batteries.
	Charge time too short	Use a battery charger with higher capacity.
	Battery temperature too low	Use the battery temperature sensor.
	Defective or old battery	Check battery and replace if necessary.
Batteries are discharged too fast	Wrong setting of the charge voltage	Check settings (see chapter 4).
	Battery capacity reduced due to wastage or sulphation, stagnation	Charge and recharge a few times, this might help. Check battery and replace if necessary.
Batteries are too warm, gassing	Defective battery (short circuit in cell)	Check battery and replace if necessary.
	Battery temperature too high	Use the battery temperature sensor.
	Charge voltage too high	Check settings (see chapter 4).
No EasyView 5 display function.	Display is switched off.	Switch on display, refer to display manual.
	Error in the wiring.	Check the MasterBus cables.
Slow or no MasterBus communication.	Error in the MasterBus wiring.	Check the MasterBus cables.
	No MasterBus Terminator placed at the ends of the network.	MasterBus needs a terminating device on both ends of the network. Check if connected.
	MasterBus network is configured as a ring network.	Ring networks are not allowed. Check the connections of the network.



## 7 TECHNICAL DATA

### 7.1 Specifications 12V models

Model	12/75-3	12/100-3
Product code	44310750	44311000
Nominal input voltage*	120/240V	120/240V
Nominal input frequency	50/60Hz	50/60Hz
Full load consumption	1300VA	1700VA
Max. AC input current (@ 240VAC)	5.6A	7.5A
Max. AC input current (@ 120VAC)	11.8A	14.9A
Nominal output voltage	14.25V	14.25V
Total charge current*	75A at 14.25V	100A at 14.25V
Number of battery outlets	3	3
Max. current Smart terminal	75A/40A	100A/40A
Max. input voltage Smart terminal	16V	16V
Charge characteristic*	IUoUo, automatic, 3-step+	
Charge voltage Bulk*	14.4V	14.4V
Charge voltage Absorption*	14.25V	14.25V
Charge voltage Float*;	13.25V	13.25V
Pre-float voltage drop	0.7V	0.7V
Max. absorption and max. bulk timer*	8 hours (start max. bulk timer at 13.25V)	
Minimum absorption time*	15 min.	15 min.
Maximum ripple voltage on DC	120mV pp	120mV pp
Battery type settings*	User defined/AGM/GEL/Flooded/AGM Spiral/Flooded traction/Flooded calcium/MLI (Li-ion)	
Dimensions (mm)	383×250×126	383×250×126
Dimensions (inch)	15.0×9.8×5.0	15.0×9.8×5.0
Weight	5,9 kg (13 lbs)	5,9 kg (13 lbs)
Recommended battery capacity	140-800Ah	200-1000Ah
Power factor regulations	≥ 0,98	≥ 0,98
Temperature compensation	Battery temperature sensor and cable included.	
Voltage compensation	Yes, by means of automatic compensation or MasterShunt	
DC consumption	<5mA	<5mA
Temperature range	-25°C (-13°F) to 80°C (176°F) Derating of 90% below 0°C (32°F) Derating 1%/°C (0,5%/°F) from 40°C (104°F) to 60°C (140°F); Derating 8%/°C (4,4%/°F) from 60°C (140°F) to 70°C (158°F); Communication available, 0% output power from 70°C (158°F) to 80°C (176°F)	
Cooling	Vario fan and natural cooling to ensure optimized cooling	
Sound level	<52dBA / 1m	
Protection degree	IP23	IP23
MasterBus connectivity	Yes	Yes
Powering capabilities for MasterBus	Yes, when the charger is switched on and AC is available, it can power up to three non-powering devices.	
Ignition protected	Yes, conforming to SAE J1171/ISO 8846	

\* Adjustable, see chapter 4 for settings.

Specifications are subject to change without prior notice.

## 7.2 Specifications 24V models

Model	24/40-3	24/60-3
Product code	44320400	44320600
Nominal input voltage*	120/240V	120/240V
Nominal input frequency	50/60Hz	50/60Hz
Full load consumption	1400VA	2000VA
Max. AC input current (@ 240VAC)	7.1A	10.1A
Max. AC input current (@ 120VAC)	12.8A	18.7A
Nominal output voltage	28.5V	28.5V
Total charge current*	40A at 28.5V	60A at 28.5V
Number of battery outlets	3	3
Max. current Smart terminal	40A/20A/10A(12V)	60A/20A/10A(12V)
Max. input voltage Smart terminal	32V	32V
Charge characteristic*	IUoUo, automatic, 3-step+	
Charge voltage Bulk*	28.8V	28.8V
Charge voltage Absorption*	28.5V	28.5V
Charge voltage Float*;	26.5V	26.5V
Pre-float voltage drop	0.7V	0.7V
Max. absorption and max. bulk timer*	8 hours (start max. bulk timer at 26.5V)	
Minimum absorption time*	15 min.	15 min.
Maximum ripple voltage on DC	240mV pp	240mV pp
Battery type settings*	User defined/AGM/GEL/Flooded/AGM Spiral/Flooded traction/Flooded calcium/MLI (Li-ion)	
Dimensions (mm)	383×250×126	383×250×126
Dimensions (inch)	15.0×9.8×5.0	15.0×9.8×5.0
Weight	5,9 kg (13 lbs)	5,9 kg (13 lbs)
Recommended battery capacity	160-400Ah	200-500Ah
Power factor regulations	≥0,98	≥ 0,98
Temperature compensation	Battery temperature sensor and cable included.	
Voltage compensation	Yes, by means of automatic compensation or MasterShunt	
DC consumption	<10mA	<10mA
Temperature range	-25°C (-13°F) to 80°C (176°F) Derating of 90% below 0°C (32°F) Derating 1%/°C (0,5%/°F) from 40°C (104°F) to 60°C (140°F); Derating 8%/°C (4,4%/°F) from 60°C (140°F) to 70°C (158°F); Communication available, 0% output power from 70°C (158°F) to 80°C (176°F)	
Cooling	Vario fan and natural cooling to ensure optimized cooling	
Sound level	<52dBA / 1m	
Protection degree	IP23	IP23
MasterBus connectivity	Yes	Yes
Powering capabilities for MasterBus	Yes	Yes
	When the charger is switched on and AC is available, it can power up to three non-powering devices.	
Ignition protected	Yes, conforming to SAE J1171/ISO 8846	

\* Adjustable, see chapter 4 for settings

Specifications are subject to change without prior notice.

7.3 Dimensions

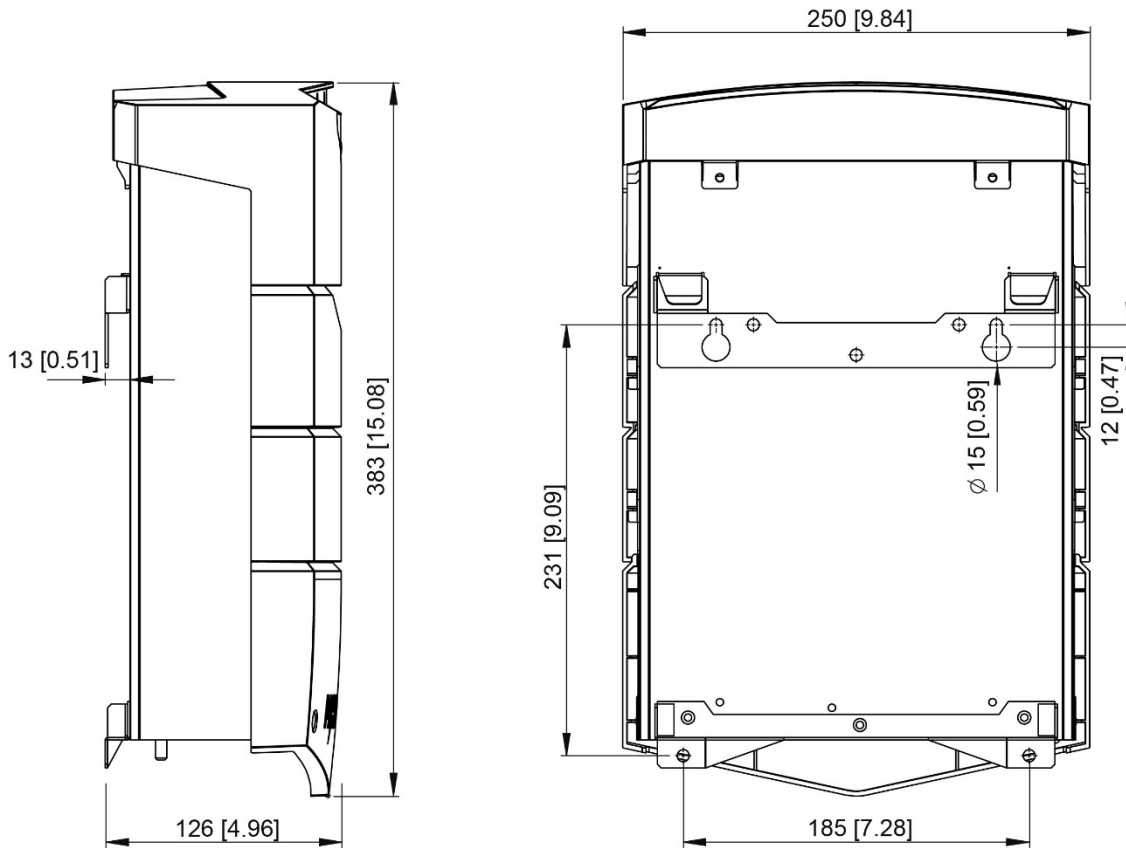

Dimensions in mm [inches] ChargeMaster Plus models 12/75-3, 12/100-3, 24/40-3 and 24/60-3.

7.4 3-Step+ charging characteristics of flooded batteries

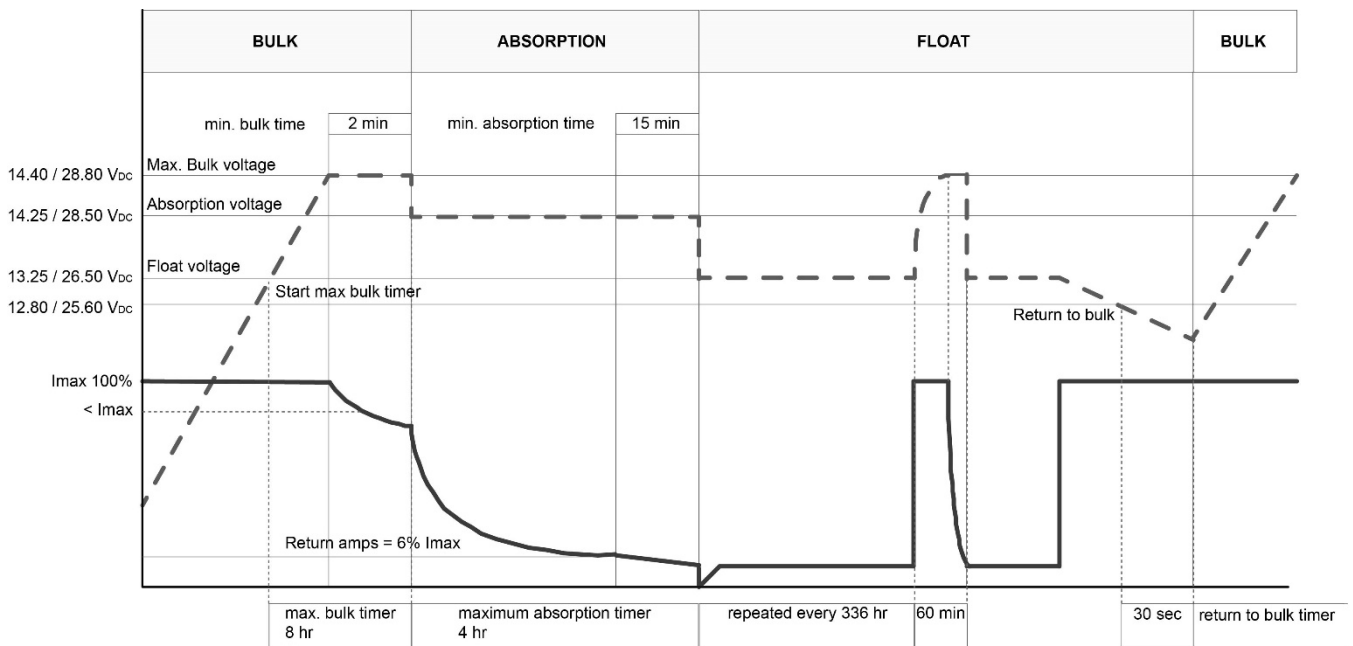



**Europe, Middle East & Africa  
Customer Service**

T: +31 (0) 20 34 22 100  
E: [info@mastervolt.com](mailto:info@mastervolt.com)

**Technical Support**

T: +31 (0) 20 34 22 100  
E: [ts@mastervolt.com](mailto:ts@mastervolt.com)

**Location & Shipping**

Mastervolt  
Snijdersbergweg 93  
1105 AN Amsterdam  
The Netherlands

**Americas & Caribbean  
Customer Service**

T: +1 800 307 6702, Option 1  
E: [orderentry@marinco.com](mailto:orderentry@marinco.com)

**Technical Support**

T: +1 800 307 6702, Option 2  
E: [tsusa@mastervolt.com](mailto:tsusa@mastervolt.com)

**Location & Shipping**

Power Products, LLC  
N85 W12545 Westbrook Crossing  
Menomonee Falls, Wisconsin 53051  
United States

**Asia Pacific**

**Customer Service**

T: +64 9 415 7261 Option 1  
E: [enquiries@bepmarine.com](mailto:enquiries@bepmarine.com)

**Technical Support**

T: +64 9 415 7261 Option 3  
E: [technical@bepmarine.com](mailto:technical@bepmarine.com)

**Location & Shipping**

BEP Marine  
42 Apollo Drive  
Rosedale, Auckland 0632  
New Zealand