

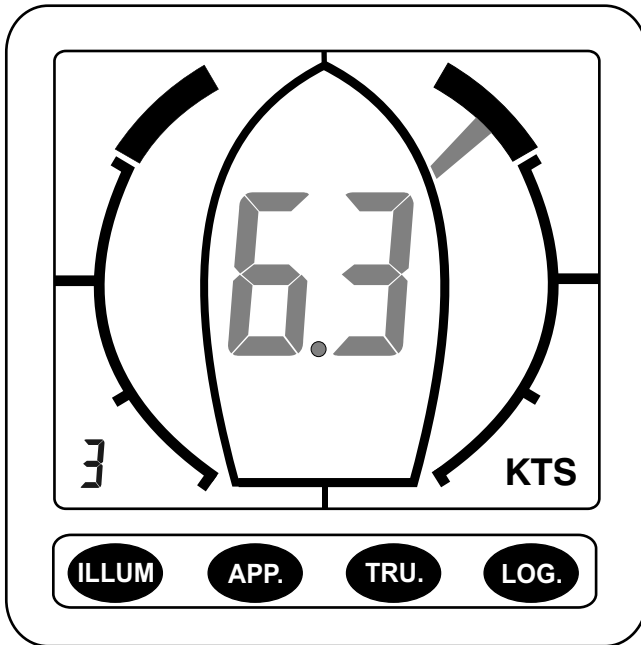

DESIGNED AND  
MANUFACTURED  
IN ENGLAND



*CLIPPER*

**TACTICAL  
WIND  
SYSTEM**

RoHS ✓  
2002/95/EC



CE



# TACTICAL WIND SENSOR (TWS-1).

## INTRODUCTION

In demanding conditions, where high performance is essential, the TWS-1 wind sensor is the ideal choice. With ten updates every second it responds quickly to the changes of wind speed and direction which occur during tricky manoeuvres. The sensor is supplied complete with a mast mounting kit, twenty metres of light weight cable and all necessary electrical connectors to complete the installation. Output data is in the NMEA-0183 format and can be used to drive any compatible display that utilises the MWV sentence.

When used with the CLIPPER TRUE WIND DISPLAY it will show apparent wind speed and direction and, when connected to a log or GPS, it can also show true wind speed and direction.

## INSTALLING THE MASTHEAD SENSOR.

Carefully loosen the four screws from the mounting plate on the underside of the sensor. Insert the short end of the anodised mounting tube fully into the slot and tighten the four screws to lock the tube in position. Drill the mast and fit the long end of the tube to the mast using the mounting blocks and screws as shown in FIG-1. Plug the twenty metre cable into the flylead from the sensor ensuring the connector is fully closed leaving no gap between the plug and socket. Now bind the connector with the self amalgamating tape provided. You will have to stretch the tape to about twice its normal length as you bind it to ensure the tape welds itself together and protects the connection. Use the tie wraps to fix the cable to the mounting tube and ensure the connector is secure and not under stress.

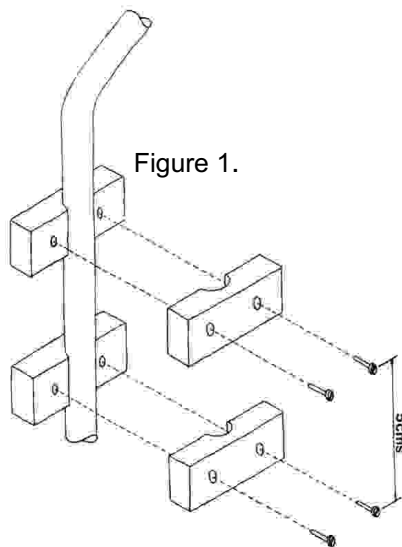

## INSTALLING THE DISPLAY.

Select a convenient position for the DISPLAY on a panel or bulk-head. The site must be flat and the cavity behind the panel must remain dry at all times. (The cable entry is deliberately not sealed to ensure adequate ventilation. This prevents misting of the display). Cut a hole in the panel 67mm high and 87mm wide.

Unscrew and remove the wing nut from the rear of the instrument and remove the stainless steel clamping bracket. Fit the "O" ring seal into the groove in the panel mounting face of the instrument. Ensure that it is correctly lying in its groove before fitting the instrument to the panel, which provides the watertight seal for the display. Pass the attached cable through the hole ready for routing to the connector assembly. Fit the instrument into the panel, fit the stainless clamp over the stud, fit and tighten the wing nut finger tight only. It is important that the O ring rubber seal makes good contact with the panel to prevent water getting behind the unit and entering the cavity behind the panel. It is good practice to run the cables vertically downwards from the unit, even if they later have to rise to connect to the master unit. Doing so prevents any water that might get onto the cables from running back along the cables and into the unit.

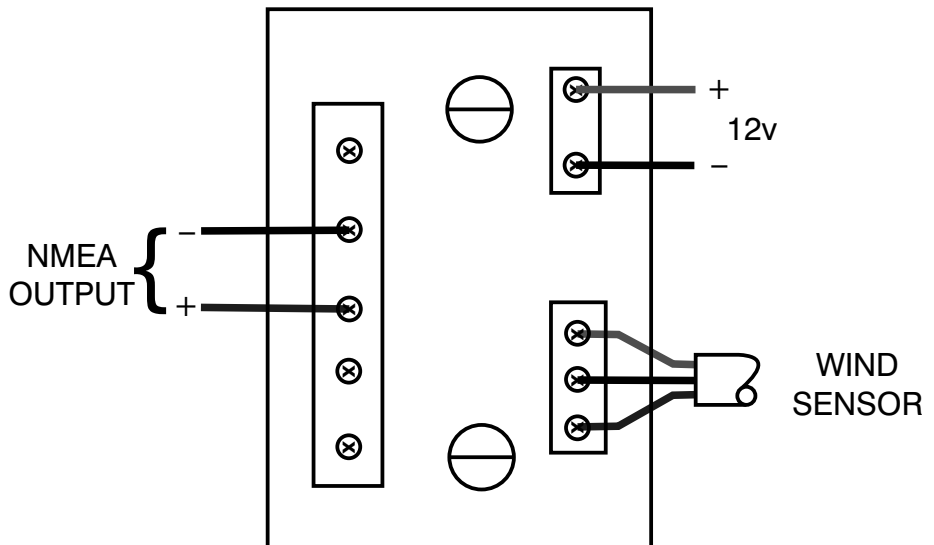

FIG 2a

## CONNECTING THE WIND SENSOR

Run the cable down the mast through to the display and connect the three wires into the small three way block of the connector assembly supplied. Connect the 12 volt power supply, via a one amp fuse, to the black and red inputs as shown in FIG-2a. Connect the display input NMEA+ to the blue wire and, if the display has an NMEA reference input then connect it to the black wire. If you are connecting to the clipper true wind display then connect as shown in FIG-2b.

## SETTING "DEAD AHEAD"

To calibrate the direction; switch on the power and point the wind vane to the dead ahead position. Using a short length of wire, touch the ends to the tops of the screws clamping the blue and the black wires of the wind sensor. This will momentarily connect the blue wire to ground and reset the mast sensor to zero dead ahead position. Remove the wire link. The dead ahead position is stored in memory.

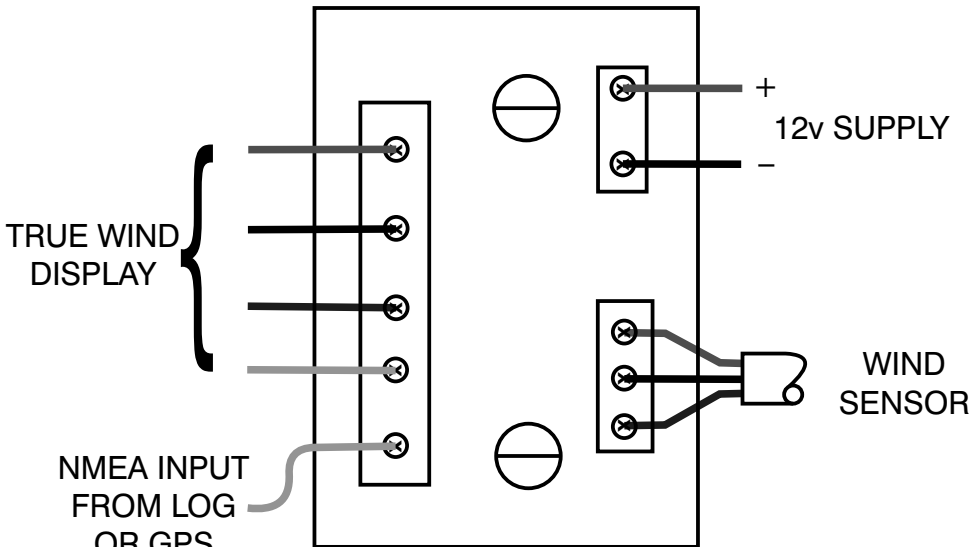

FIG 2b

## USING THE CLIPPER TRUE WIND DISPLAY

Pressing ILLUM will increase the level of backlighting from level one through to level nine. The character at bottom left of the display will briefly show the new lighting level before returning to “A” for apparent wind, “T” for true wind or “L” for boat speed.

Selecting APP. displays the apparent wind speed and direction, TRU. displays true wind speed and direction and LOG. displays boat speed.

Simultaneously pressing ILLUM and APP. will alternate between undamped “U” and damped “D” readings.

Simultaneously pressing APP. and TRU. will alternate between the STANDARD pointer or the windex pointer style as shown in FIG 3.

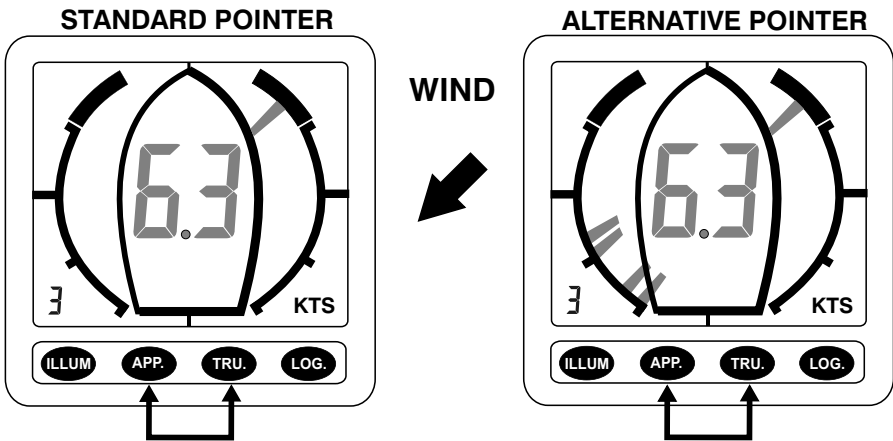

FIG 3



# IMPORTANT READ THIS BEFORE UNPACKING INSTRUMENT

Prior to unpacking this instrument read and fully understand the installation instructions. Only proceed with the installation if you are competent to do so. Nasa Marine Ltd. will not accept any responsibility for injury or damage caused by, during or as a result of the installation of this product. Any piece of equipment can fail due to a number of causes. Do not install this equipment if it is the only source of information and its failure could result in injury or death. Instead return the instrument to your retailer for full credit. Remember this equipment is an aid to navigation and not a substitute for proper seamanship. This instrument is used at your own risk, use it prudently and check its operation from time to time against other data. Inspect the installation from time to time and seek advice if any part thereof is not fully seaworthy.

## LIMITED WARRANTY

Nasa Marine Ltd. warrants this instrument to be substantially free of defects in both materials and workmanship for a period of one year from the date of purchase. Nasa Marine Ltd. will at its discretion repair or replace any components which fail in normal use within the warranty period. Such repairs or replacements will be made at no charge to the customer for parts and labour. The customer is however responsible for transport costs. This warranty excludes failures resulting from abuse, misuse, accident or unauthorised modifications or repairs. In no event shall Nasa Marine Ltd. be liable for incidental, special, indirect or consequential damages, whether resulting from the use, misuse, the inability to correctly use the instrument or from defects in the instrument. If any of the above terms are unacceptable to you then return the instrument unopened and unused to your retailer for full credit.

Name \_\_\_\_\_

Address \_\_\_\_\_  
\_\_\_\_\_

Dealer Name \_\_\_\_\_

Address \_\_\_\_\_  
\_\_\_\_\_

Date of Purchase \_\_\_\_\_

**Proof of purchase may be required for warranty claims.**

**Nasa Marine Ltd.  
Boulton Road, Stevenage, Herts SG1 4QG England**

### **Declaration of Conformity**

NASA Marine Ltd declare this product complies with the essential requirements, which are specified in the directive 2004/108/EC on the approximation of the laws of the Member States relating to electromagnetic compatibility. Harmonised standards applied: 2004/108/EC EN60945:2002

The original Declaration of Conformity certificate can be requested at [info@nasamarine.com](mailto:info@nasamarine.com)

**THIS PRODUCT IS INTENDED FOR USE ONLY ON NON SOLAS VESSELS**

