

Dimensions

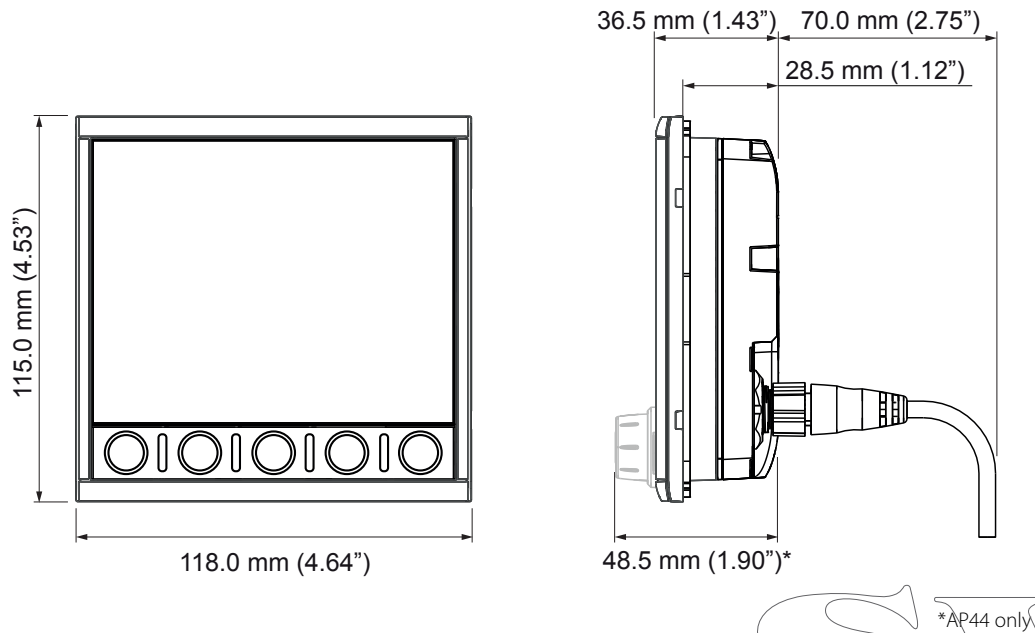

SIMRAD

B&G

AP44 / IS42 / Triton² INSTALLATION GUIDE

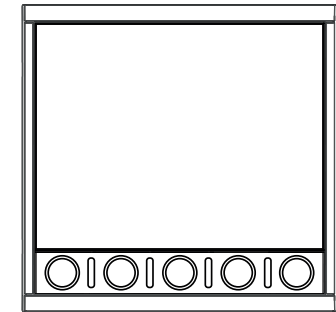
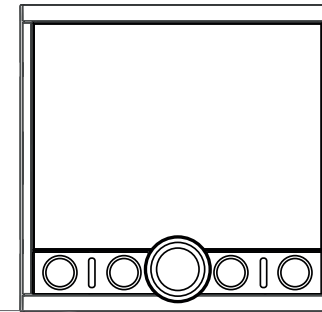

Parts included

1. 1 x Display unit + Removable bezel
2. 1 x Micro-C Drop cable - 0.6 m (2')
3. 1 x Micro-C T-Connector
4. 4 x Mounting screws
5. 1 x Suncover
6. Mounting template
7. Screw jig

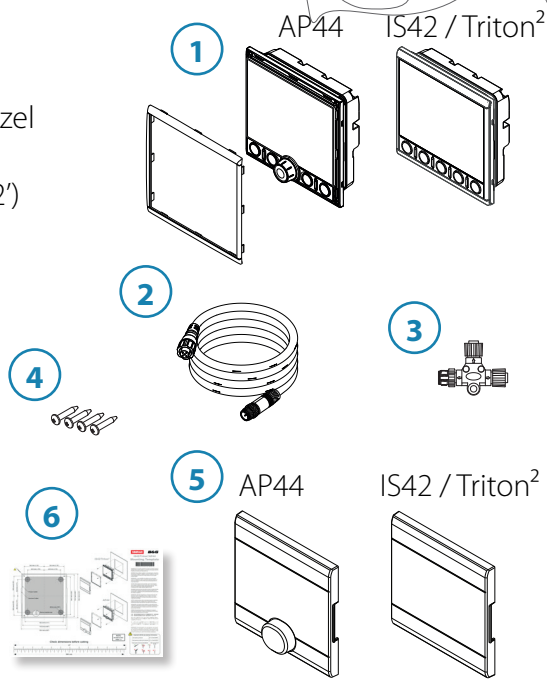

For product manuals, technical specifications, certificates and declarations, refer to the product website:

www.simrad-yachting.com

www.bandg.com



* 9 8 8 - 1 1 2 2 9 - 0 0 1 *

Mounting

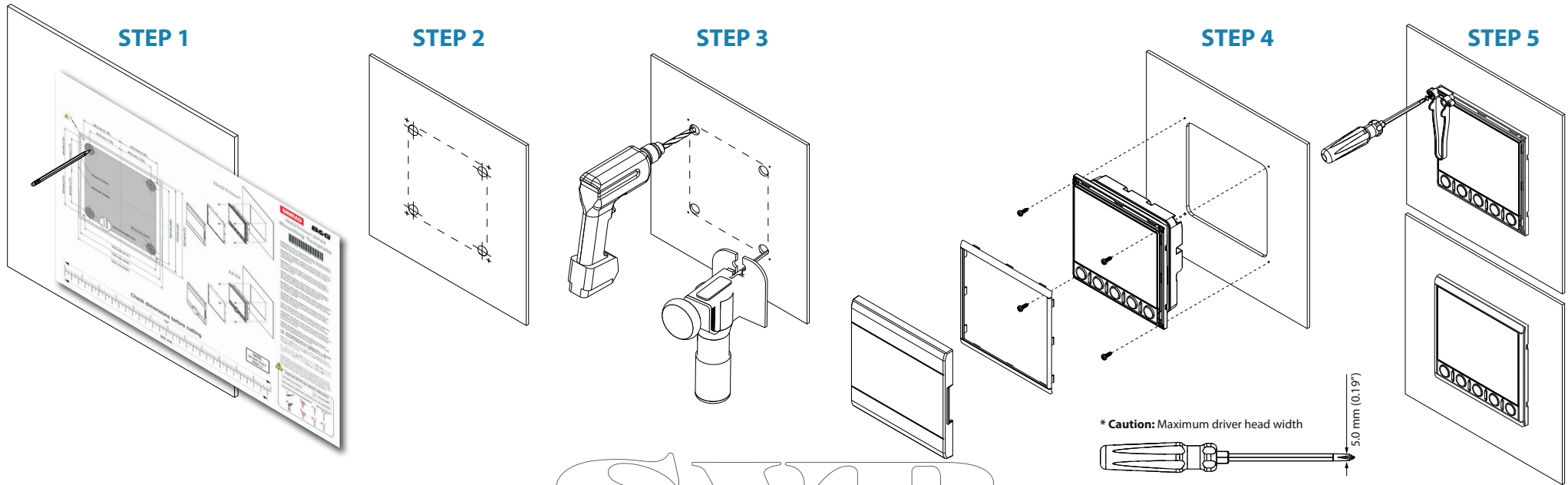

S V B

System wiring example

Simrad

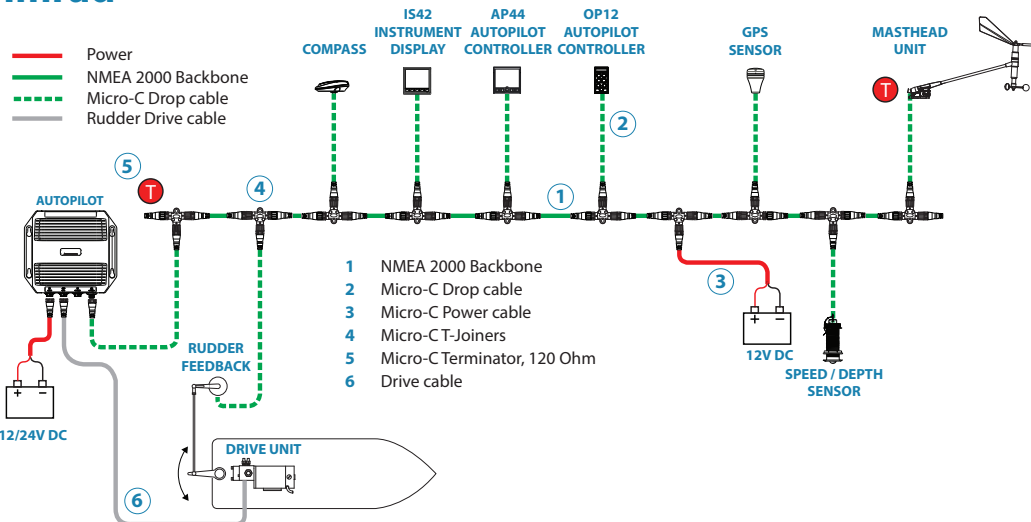

B&G

